

# SUB THEMES FOR THE CONFERENCE

## Track 1 - Human Resource Management:

1. Global Reporting Initiatives and Corporate Sustainability
2. HR Vision for 21<sup>st</sup> century
3. Social Media Recruiting: Strategies for new era
4. Performance Management systems
5. Human Values, Ethics and Corporate Social Responsibility
6. Work Life Balance
7. Managing Diversity in Business
8. Role of HR in Organisational innovation
9. Union Substitution strategy and Co-partnership
10. Green HRM
11. HR Scorecard for 21<sup>st</sup> century
12. HR analytics
13. Global Mindset and Global Relationship
14. Industrial Relations: Giving a way to employee Relations
15. Expanding flexible work arrangements to meet needs of changing family structures

## Track 2 - Marketing:

1. Green Marketing and Responsible Consumerism
2. Sustainability Development Agenda 2020
3. Role of Blue Ocean Strategy in Business
4. Consumer Behaviour and technology
5. Impact of Branding and Advertising in 21<sup>st</sup> Century
6. Growth and development in Rural Marketing
7. Marketing channels and strategic sales force management
8. Sustainability and smart cities
9. Export marketing strategies and performance in technological era
10. Integrating Marketing Communication
11. Services marketing and New Technologies
12. Role of Technology in Industrial Marketing and event marketing
13. Innovation and creativity in marketing
14. Marketing in Digital Era
15. Marketing For Entrepreneurs

## Track 3 - Finance:

1. Evolution of technology in Financial Markets
2. FinTech Drivers of Digital India
3. FinTech Revolution to transform the Financial Services including processing of Instant Payments; Open Platforms; Mobile Payments; and Wallets
4. Challenges of Cybersecurity in Banking, FinTech and Transaction Environment
5. International Payment Transformation: Ripple
6. Next Generational Retail Commerce
7. Role of FinTech in Financial Inclusion and Financial Integration
8. E-cash Payment systems
9. Plastic Currency: Challenges and Opportunities
10. Corporate Governance and market leadership
11. Liquidity Shortage and Companies Credit Crunch
12. Ambiguity and other decisional rules in finance
13. Asset Bubbles
14. Role of Derivates in Financial System
15. Challenges for India: Growth, Competitiveness, Innovation and Well Being

## Track 4 - International Business:

1. Inclusive and Equitable Economic Growth
2. Social Businesses, Sustainable Innovation and Ecopreneurship

3. Internationalisation of developing country firms- MNC's
4. Technological change: Causes and Impact on International Business and their Strategies
5. Role of International mergers and acquisitions in business
6. Globalisation and consequences of International Fragmentation
7. Cross Cultural Communication Process and Negotiations
8. Make in India: Challenges for MNC's
9. Mode of Entry Strategies to Foreign Markets
10. Ethnocentric Approach of International Business
11. Factors Affecting International for Foreign Exchange
12. Implications of FDI for Business
13. International Dimensions of Organisational Behaviour
14. Management myopia as restraining force for global marketing
15. Broad marketing strategies – Cost Leadership advantage

## Track 5 - Information Technology:

1. Utilization of Cloud technology to make IT more efficient and Cost effective
2. Smart sensors help curb environmental pollution
3. IOT: Internet of Things
4. Artificial Intelligence used to record mental disorders
5. Robotics
6. Nano Technology
7. Automation in 21<sup>st</sup> century
8. Hydrogen Power Cars
9. Human Cloning: Challenges and Opportunities
10. Biometric Technology for automatic Identification of individual
11. Cyber Terrorism
12. Night Vision Technology
13. GPS and its Application
14. Bluetooth Based Smart sensor Networks
15. Fuzzy Logic Technology

## Track 6 - Operational:

1. Impact of IT on Productivity
2. Effective Utilisation of ERP in Operations and SCM
3. Growth of E-Commerce in Indian Environment
4. Business Process Outsourcing in manufacturing environment
5. Lean Manufacturing
6. Cost Effective solutions in bound logistics
7. Bottleneck Elimination
8. Crunching Lead Times across services as well in product industries
9. MRO & Spare parts
10. Warehouse Management in 21<sup>st</sup> century
11. Implementation of TQM in Business
12. Tools in Six Sigma – An Overview
13. JIT Logistics
14. Service Level Quality: Standards, Measures, Monitoring and Enhancing
15. Inventory Analysis Techniques

## Track 7 - Education & Research

1. Humanities & Social Science
2. Arts, Literature & Regional Studies
3. Agriculture & Public Health
4. Philosophy, Psychology & Social work
5. Law & Applied Science



**Mangalmai Institute of  
Management and Technology**  
Greater Noida

In Association with,



**Kaav  
Global Conference**  
Delhi



**Managerial Strategies for  
Technological Transformations in  
21<sup>st</sup> Century**

9<sup>th</sup> February, 2019, Saturday



8 and 9, Knowledge Park II, Greater Noida, U.P. 201310

Contact No.: Dr. Amit Gupta - 7906614898, 7678387243

Dr Kirti Agarwal - 9810084690, Sarika - 7683095844

E-Mail: [mimconference2019@gmail.com](mailto:mimconference2019@gmail.com)

Website: [www.mangalmai.org](http://www.mangalmai.org), [www.globalconference.info](http://www.globalconference.info)



### Chief Patron

**Hon. Shri Atul Mangal**

Chairman, Mangalmay Institute of Management & Technology



### Patron

**Hon. Shri Anuj Mangal**

Vice-Chairman, Mangalmay Institute of Management & Technology



### Chief Editor

**Dr. Tushar Kanti**

Director, Mangalmay Institute of Management & Technology



### Editor

**Dr. Amit Gupta**

Head of the Department, Mangalmay Institute of Management & Technology

### Convenor

**Dr. Shweta Kulshrestha** (Associate Professor)

### Kaav Conference Convenor

**Dr. Kirti Agarwal** (Kaav Global Conference, Delhi)

### Advisory Committee

**Dr. Neeraj Goel**, Ph.D., MBA, M.Sc. (Chairman, Center for Behavioural Studies & Career Development)

**Dr. N.M. Mishra** (Professor, Institute of Management & Technology)

**Dr. Manoj Kumar Agarwal**, Ph.D., FCS, LL.B. (Associate Professor, Department of Commerce, Meerut College, Meerut.)

**Dr. Arvind Yadav**, Ph.D. M.A., MBA, M.Com. (Head, Faculty of Commerce, KM Government Girls PG. College, Badalpur.)

**Dr. Pankaj Kaushik** (Major General, Indian Army)

**Dr. Gaurav Joshi** (Ph.D., MBA), Renowned Research Analyst expert, G.B. Pant Univ. of Agriculture & Tech. and MBA.

**Dr. (Prof) Samir Gopalan** (Ph.D., MBA), Prof. & HOD in Indus Univ, Gujarat.

**CA. (Dr.) S.K. Lal** (Ph.D., Chartered Accountant) IFRS expert, Delhi & Nepal

**Dr. Vikrant Agarwal** (Ph.D., MBA, B.Tech.) Consultant & QA Head, Wipro, Gurugram

### Organising Committee

**Dr. Julee Banerjee** (Associate Professor)

**Mrs. Monika Makhija** (Assistant Professor)

**Mrs. Seema Pundir** (Assistant Professor)

**Mrs. Shruti Srivastava** (Assistant Professor)

**Mrs. Anita Ramrakhiani** (Assistant Professor)

**Mr. Alvin K Antony**

**Ms. Sarika**

### Technical Committee

**Mr. Sushil Maurya** (Assistant Professor)

**Ms. Meha Mathur** (Assistant Professor)

**Ms. Pooja Kapoor** (Assistant Professor)

### International Advisory Committee

**Dr. Dileep Kumar M.** (MA (HR), MSW – HRM - NGO Management), MPhil (Labour Studies), PhD (OB), PGDHRM, PGDCA, PGDM, DHA, DLL, Prof. School of Business (OYA-GSB) Universiti Utara Malaysia

**Dr. Pham Hung Cuong** (MBA, Ph.D., FTU, Ho Chi Minh City Campus, Director of The Center for IEC, Vietnam)

**Dr. Mohd Norfian Alifiah** (Ph.D., MBA, Senior lecturer in Universiti Teknologi Malaysia.)

**Dr. Manoj Choudhary** (Ph.D., MBA, Professor, Tribhuvan University, Kathmandu)

### Registration Fees\*

Category	Earlybird Registration	Registration After 15 <sup>th</sup> Jan. 2019
Students	Rs.1000/-	Rs.1200/-
Research Scholars	Rs.1600/-	Rs.2000/-
Faculty/Academicians	Rs.1800/-	Rs.2200/-
Industry/Corporate Professionals	Rs.2000/-	Rs.2400/-
Foreign Delegates	US\$50	US\$80
Poster Presenter	Rs.800/- Separate Poster Gallery/Space will be provided	
Spot Registration	Additional Rs.400/- for each category	
*Registration fees excluding accommodation & transportation		

**Registration fees includes: Conference Kit, Two Certificates presentation & publication, Edited book copy, Lunch, Snacks, Tea etc. All full papers will be published in Edited book with ISBN. Papers in absentia is also acceptable.**

### Guidelines for submission or papers:

1. Please submit the abstract of 120-250 words by email with track
2. Text should be in MS- Word, times new roman; with font size 12 and 1.5 line spacing not more than 4000 words
3. Cover page to provide title of paper, author(s) name, designation, address and contact details, including Email Id.
4. Plagiarism below 30% including references, title and designation.

**All Correspondence regarding Paper submission are to be done through E-Mail [mimtconference2019@gmail.com](mailto:mimtconference2019@gmail.com)**

**Websites: [www.mangalmay.org](http://www.mangalmay.org), [www.globalconference.info](http://www.globalconference.info)**

**For Details Please Contact:**

**Dr. Amit Gupta - 7906614898, 7678387243**

**Dr. Kirti Agarwal: 9810084690; Ms. Sarika: 7683095844**

### MODE OF PAYMENT

**Kaav Media Pvt. Ltd.**

**Andhra Bank, Branch- Mayur Vihar phase- 3, Delhi-110096**

**Current A/c No.:- 208611100000326 IFSC:- ANDB0002086**

### Office Address:

**Kaav Global Conference  
203, 2nd Floor, Plot No- 7, Aggarwal Plaza, LSC- 1,  
Mixed Housing Complex, Mayur Vihar Phase 3, DELHI- 110096  
011-22626549, 9810084690, 7683095844  
[www.globalconference.info](http://www.globalconference.info)**

### Best Paper/Presentation Awards

- 02 Best Paper Award
- 02 Best Paper Presentation Award
- 02 Best Poster Presentation Award
- 02 Best Overall Performer/Complimentary Award

### Places to visit in Delhi (NCR)



### About the Institute

The genesis of the NAAC accredited and ISO certified, Mangalmay Group of Institutions was in the year 2002, when it commenced its programs with and Management, Biotechnology and Education, Undergraduate and post graduate courses, with the passage of time, the Engineering program joined the bandwagon. The institution enrolls over 2000 students drawn from the various states in the country and even from across the sovereign borders. The institution, housed in a 6 acre plot of land, strategically located in the heart of the corporate cluster in Greater Noida, is replete with state- of- the art infrastructure and amenities and features prominently among the list of premier academic institutions in Delhi/NCR. It has a vision to create an institution with world class-academic systems, learning methodologies, infrastructure and faculty and resourceful placement cell which would supplement the tenacious sculpting of global business and techno- leaders of tomorrow, with an emphasis on nation building.

Courses: MBA, BBA, B.Sc Biotechnology, B.Com, BCA, B.Ed., D.El.Ed., B.Tech.

### About Conference

International conferences provide an opportunity to encourage regional and International communication and collaboration which not only helps in disseminating knowledge and share experiences but also enhances research aptitude and attitude among the researchers in multidisciplinary areas. Present conference aims at knowing and understanding the innovative and the best practices involved for Management, Social Science, Education and Globalization Development.

### About Kaav Global Conference

Kaav Global Conference is a Delhi based leading international organization in the field of academic research worldwide. It is a unit of Kaav Media Pvt. Ltd., registered from New Delhi, India since 2013. Kaav Global Conference provide a platform to worldwide researchers, academicians, corporate professionals to show their abilities. It has organised several successful conferences, workshops and training programs, at various reputed institutions and grand venues. Kaav Global Conference provides professional conference, management & technical services to scholarly associations, institutions and professional bodies.

Other wings:- Kaav Institute of Professional Studies, Kaav Publications and Smt Vimla Devi Education Society (SVDES) - NGO

## AWARDS

### Nomination Awards

- Award for Contribution to the Education Sector/Social Sector/Research & Development
- Award for the Think Thank in Technical Education
- Award for professors with Excellence in Teaching in Higher Education
- Award for Achievement of Excellence in Career Guidance and Placements
- Award for Cutting -edge Researches
- Award for Excellence in Surgical Skill and Social Services

**Note:** For these awards, please send your resume (latest by 25th Jan 2019). On the basis of review committee decisions, nominees will inform accordingly with nominal fees. **E-mail: [mimtconference2019@gmail.com](mailto:mimtconference2019@gmail.com)**



# Technological and Managerial Strategies for Next Generation Transformation

Chief Editor  
**Tushar Kanti**

Editors  
**J.N.Giri**  
**Harish Bhatia**

Co-Editors  
**Jyotsna Pandit**  
**Amit Gupta**

**BLOOMSBURY**

**Technological and  
Managerial Strategies for  
Next Generation Transformation**



# Technological and Managerial Strategies for Next Generation Transformation

**Chief Editor**

Tushar Kanti

**Editors**

J.N. Giri • Harish Bhatia

**Co-Editors**

Jyotsna Pandit • Amit Gupta

B L O O M S B U R Y  
NEW DELHI • LONDON • OXFORD • NEW YORK • SYDNEY



© Mangalmay Group of Institutions, Greater Noida, 2017

*First published, 2017*

All rights reserved. No part of this publication may be reproduced or transmitted in any form or by any means, electronic or mechanical, including photocopying, recording, or any information storage or retrieval system, without prior permission in writing from the copyright holder.

No responsibility for loss caused to any individual or organization acting on or refraining from action as a result of the material in this publication can be accepted by Bloomsbury India or the author/editor.

BLOOMSBURY PUBLISHING INDIA PVT. LTD.  
New Delhi London Oxford New York Sydney

ISBN: 978-93-86432-66-7

10 9 8 7 6 5 4 3 2 1

Published by Bloomsbury Publishing India Pvt. Ltd.  
DDA Complex LSC, Building No. 4, 2<sup>nd</sup> Floor  
Pocket 6 & 7, Sector C  
Vasant Kunj, New Delhi 110070

Laser Typeset by FORTUNE GRAPHICS, Naraina, New Delhi

Printed at ANVI COMPOSERS, Paschim Vihar, New Delhi

The publisher believes that the contents of this book do not violate any existing copyright/intellectual property of others in any manner whatsoever. However, in case any source has not been duly attributed, the publisher may be notified in writing for necessary action.

# Contents

<i>Preface</i>	xi
<i>Acknowledgements</i>	xiii
<b>SECTION 1: TRANSFORMING BUSINESS FINANCES</b>	
1. Corporate Social Responsibility: An Analysis of its Tax Implications in Indian Perspective <i>Sripal Srivastava and Anjali Dubey</i>	3
2. Benefits of GST for Startup Business in India? <i>Rashmi Gujrati</i>	15
3. Technology Upgradation on the Functioning of Indian Banking Sector <i>Anashul Sharma and Someh Kumarz</i>	23
4. Impact of Goods and Service Tax on Oil and Natural Gas Industry – A Case Study of Indian Oil Corporations Ltd. <i>Sonal Gupta And Akshit Gupta</i>	31
5. The Impact, Outreach and Sustainability of Microfinance Institution in Developing Nations <i>Pallavi Pandey</i>	41
6. The Trend of Various Start-Ups to Domicile Overseas: An Overview of Current Scenario in Venture Capital Funding <i>Deepak Bansal</i>	49
<b>SECTION 2: CHANGING PARADIGMS OF ECONOMY</b>	
7. A Case Study on Political – Socio-Economic Scenario in November 2016 Post Demonetization: Technological Transformation by Cashless Economy Through Digital India <i>Rajeev Sijariya</i>	61
8. The Practice of ICT in Classroom <i>Raj Lakshmi Raina</i>	69
9. The Impact of Digitalization on Economy <i>Monika Kadam and Neha Yadav</i>	73
10. Role of Media in Making India a Cashless Economy: An Overview <i>Kamaljeet Kaur</i>	80
11. Communication, Technology and Media Revolution <i>Akansha Arora</i>	84



### SECTION 3: TECHNOLOGY AND INNOVATIONS FOR

12. Next Generation: Body Mobile Changer <i>Shammi Kumar and Jyotsna Pandit</i>	91
13. Seamless Mobility of IP Connectivity of Manet in Disaster Area <i>Anand Prakash Srivastava and Payal Kansal</i>	102
14. Anatomy of Android Application <i>Anand Prakash Srivastava, Payal Kansal and Sushil K Maurya</i>	107
15. An Insight into Influencing Factors Towards Buying Behaviour of Fast Moving Consumer Goods by Rural Consumers <i>Pradeep Kumar Mishra and N.L. Mishra</i>	119
16. Finite Termination by Using the Asymptotic Dual for Dynamic Bundle Method <i>Paras Bhatnagar and Prashant Chauhan</i>	133
17. Solvent Effect on Electronic Absorption Spectra of 2, 5-Dimethoxy Thio Phenol <i>Pradeep Kumar and Harish Bhatia</i>	137
18. Removal of High Density Impulse Noise using Efficient Median Filter for Digital Image <i>Ritu Sharma and Vijai Singh</i>	141
18. Pervasive SMS Spam Filtering: Pervasive Innovations, Methods and Data <i>Rubil Jain, Alok Katiyar and A.K. Soni</i>	150
20. Cost Analysis of a Complex System Under Logical and Human Errors <i>Shailja Sharma</i>	159
21. An Analysis of Misclassification of Spam and Non-Spam e-mails Using Data Mining Techniques <i>Shrutika Saini, Avdhesh Gupta</i>	168
22. Encryption And Embedding in all Multimedia Files <i>Suha Khan, Tanvi bakshi, Avdhesh Gupta</i>	176
23. Encryption and Embedding in all Multimedia Files <i>Suha Khan, Tanvi bakshi, and Avdhesh Gupta</i>	180
24. Overview of Attacks and Security Threats in Wireless Sensor Networks (WNS) <i>Pragya Tripathi, Santosh Kumar and Vikas Singh</i>	184
25. Weat-We Are There <i>Mukta Tiwari, Shivansh Singh</i>	191
26. Weat-We Are There <i>Mukta Tiwari and Shivansh Singh</i>	197
27. India Towards Cashless Economy <i>Rajat Gupta</i>	203

28. Optimization of Shell and Tube Type Heat Exchangers Using Sequential Quadratic Programming Algorithm 209  
*Abhishek Sachan and Rajive Gupta*
29. Bandwidth Improvement of Corner Truncated Square Shaped Patch Antenna Using Slots 221  
*Dhananjay Singh and Ambica Yadav*
30. A Survey on IoT Based Water Quality Monitoring System 226  
*Apoorva Sharma and Pankaj Sharma*
31. The Beneficial Data Storage Technique: RAID 233  
*Arvind Kumar and Sachin Kumar*
32. Real Time Tracking and Monitoring System for any Mobile Applications 244  
*Basanta Mahato*
33. Study of Bromide Ion Sensitive Indicator Electrode 252  
*Devendra Singh and Ashok Kumar*
34. Finish Hard Turning of En31 Steel Using Minimum Quantity Lubrication: Surface Integrity Analysis 262  
*Namit Singh Bhadauria and Gaurav Bartarya*
35. Experimental and Theoretical (ab initio/ HF) Analysis of Vibrational Spectra, Thermodynamic Functions and Non-linear Optical Properties of 2,6-Dimethyl-4-nitrophenol 269  
*Sarvendra Kumar, Surbhi and M.K. Yadav*
36. Studies on Solidification Behaviour of Some Pure Components, Eutectics and Adducts 282  
*Ashok Kumar Singh and Piyus Kumar Pathak*
37. Futuristic Technology: Screenless Display 286  
*Priyanka Gupta and Himanshi Gupta*
38. Current Role of Neem (*Azadirachta indica*) as per Pharmacology and Pharmaceutical Carrier: A Review 290  
*Sandeep Kumar, Om Kumar, Abha Ahlawat and Lalita Payal*
39. On Recurrent Lightlike Hypersurfaces of Indefinite Almost Hyperbolic Hermitian Manifold With Quarter-Symmetric Metric Connection 297  
*Shikha Tiwari and Sushil Shukla*
40. Big Data and IOT its Current Trends and Technology 303  
*Yaduvir Singh, Sarvachan Verma and Pradeep*
41. Mining and Identification of Human Behavioral Patterns using Scalable Algorithms 307  
*M. Chandra Prabha*

#### **SECTION 4: HRM - THE ROAD AHEAD**

- |   |     |
|---|-----|
| 42. Developing a Stakeholder Communication Strategy: The Case of Indian Railways and Swachh Campaign<br><i>Ranjan Kumar</i>                         | 311 |
| 43. Strategies to Enhance Employability of Graduates from Technical Institutions<br><i>Prachi Agarwal and Mini Amit Arrawatia</i>                   | 324 |
| 44. Differential Cross Sections Parameters of Alkali Atoms<br><i>Ravi Shanker, R.S Upadhyay, V.K. Goyal and Sachin Saxena</i>                       | 328 |
| 45. Body Language in Business Negotiations<br><i>Apeksha Mishra</i>   | 333 |
| 46. Teaching Communication as an Outcome Means<br><i>Dr. Apeksha Mishra</i>   | 343 |
| 47. Digital Innovation Strategy: A Framework for Diagnosing and Improving Digital Product and Service<br><i>Ashima Rathee and Meenakshi Bhaskar</i> | 352 |
| 48. Data Security Approaches: Data Warehouse Components<br><i>Nirmal Sharma and Sushil K Maurya</i>   | 358 |
| 49. Human Resource Management: Issues, Challenges, Functions and Model<br><i>Kiran Tiwari and D N Tiwari</i>  | 364 |

#### **SECTION 5: EMERGING BUSINESS MODELS**

- |   |     |
|---|-----|
| 50. A Paradigm Shift Towards Pro-People and Pro-Active Better Governance Initiatives of India<br><i>Deepti Sharma and Vikas Misra</i>               | 369 |
| 51. Will Automation and Artificial Intelligence Disrupt the Future Workplace?<br><i>Jayanta Chakraborti and Sushil Maurya</i>                       | 376 |
| 52. Digital India<br><i>Antika bhargava</i>   | 383 |
| 53. E-Commerce: Tool for Empowering Women<br><i>Raghvendra Singh Kalchuri and Seema Chhabra</i>   | 388 |
| 54. Corporate Social Responsibility and Sustainable Development<br><i>Sanjana Tewari</i>  | 393 |
| 55. Digital India – The Implimentation<br><i>Manish Singh</i>   | 399 |
| 56. A Study on Consumer Adoption towards Digital Modes of Payments with Special Reference to Gwalior City<br><i>Pankaj Mishra and Anil Vashisht</i> | 405 |

57. Analytical Study on What Consumers Demand, Expectations and Perceptions Are <i>Ateeq Ahmed</i>	410
58. Marketing Strategies in the Indian Banking Service Sector <i>Naresh Kumar, Santosh Kumar Yadav and Vivek Srivastava</i>	415
59. Content Based Information Retrieval System with Special Reference to e-Governance <i>Piyush Gupta and Sushil Kumar Maurya</i>	426
60. Robust Approach of Compressing Images and Analysis of Parameter PSNR, CR with Gamma Effect <i>Shivangi Gupta and Avdhesh Gupta</i>	432
61. Time Series Forecasting of Some Meteorological Parameters using Statistical Model <i>Garima Jain and Bhawna Mallick</i>	442
62. Diversity Management at Manchester United: A Case Study on the Alex Ferguson Era <i>Sushant Pandey</i>	453
63. Next Generation Entrepreneurship Through Technological Innovation <i>S. S. Pipara and Deeksha Mathur</i>	468
64. Cause-related Marketing in India: Effect of Cause Involvement on Purchase Intention <i>Vivek Aggarwal and Vinod Kumar Singh</i>	485
65. Mergers and Acquisitions – The way for Next Generation Transformation <i>Richa Agrawal</i>	493
66. A Study on Consumer Online Shopping Behaviour <i>Smita Dron</i>	498
67. Women Entrepreneurship-Need of Today <i>Meenakshi Sharma</i>	504
68. Corporate Governance: An Emerging Trend towards Global Market Economy <i>Subroto Ganguly and Chandrani Ganguly</i>	511
Author Index	519



# Preface

With technology advancing leaps and bounds, modern management mantras and techniques abounding, social and environmental issues gaining widespread attention and the globe becoming one small village, the day of reckoning for the stakeholders has come. The time to understand, that the past is history, the present is also going to be history and what now counts is the future. And the future is now!

It is the next generation and its needs and drives that will make or break the aspirations of business organizations ranging from conglomerates to start-ups. Therefore it is time to start investing in Next Generation Transformation.

The Nexters (also called Generation Y) have lived much of their lives with ATMs, DVDs, smart phones, laptops and the Internet along with the onset of the robotics phenomenon. More than any other generation they tend to be questioning, socially conscious and entrepreneurial.

Such a scenario, where there is a paradigm shift in the composition, perception and wants of the customers, underscores the fact that there are, and going to be, multi-faceted challenges for industry and the State.

With a view to challenge rather than succumb, create rather than surrogate and lead rather than follow – organizations and other stakeholders will have to plan and execute options through global, innovative and inclusive technological and managerial strategies, keeping in mind the bottom-line and other socio-economic factors.

The book is an effort to collect, assimilate, synthesize and disseminate the thoughts, views, opinions and knowledge of the contributors with a view to provide a comprehensive and integrated action framework within which strategies for the future may be evolved.

The present volume includes selected research articles/papers/case studies as received from the contributors. The research papers have been compiled and presented in a logical and sequential manner keeping in mind the diverse and multifarious needs of academicians, research scholars, students and practitioners.

We expect this volume to be beneficial and provide insights into the finer points of the theme.



# Acknowledgements

We are grateful to Sh. Atul Mangal, Chairman, Mangalmay Group of Institutions, who wholeheartedly consented to conduct this International Conference and gave entrusted support.

We would also like to express our sincere gratitude to Sh. Anuj Mangal, Vice Chairman, Mangalmay Group of Institutions for his continuous support & guidance in organizing this International Conference and the motivation to make it a grand success.

This book could not have been compiled without the help of some very important and special persons. This was only the encouragement of Mr. R. Anand, Sr. Vice President, HCL Technologies Ltd., Mr. Pankaj Dubey, Country Head & Managing Director, Polaris India Pvt. Ltd, Mr. Vishwajeet Tyagi, Head-HR, Samtel Avionics Ltd., Mr. O.P. Khanduja, Business Head, DS Spiceco, Mr. Manmohan Bhutani, Vice President-HR & Business Operations, ACS Global Tech Solutions, Mr. Durgesh Sharma, Director General, Fibre Cement Products Manufacturers Association., Mr. Dhananjay Singh, Executive Director & CEO, NHRDN, Mr. Chetanya Vali, Vice President, Gunnebo India Pvt. Ltd. that we could compile the book in this form.

Our sincere appreciation to Dr. Jyotsna Pandit, Dr. Amit Gupta, Ms. Ruchi Dhody, Dr. Sunil V. Deshpande, Dr. Ashima Rathee, Ms. Minakshi Bhaskar, Dr. Pradeep Kumar, Dr. Yaduveer Singh, Er. Basanta Mahato, Er. Dhananjay Singh, Er. Sachin Kumar Er. Sarvachan Verma and Er. Anand Prakash for their cooperation in bringing out this volume. Our sincere thanks to Mr. Satyabrat Mishra of Bloomsburry Publishing India Pvt. Ltd. for his support.

This book took the shape with the active participation of academic colleagues from around the world. A large number of expert faculty & Scholars from academia and Industry responded to the call for an International Conference-2017 on Technological and Managerial Strategies for Next Generation Transformation. The motivation for bringing out this book came from the students, research scholars and faculty members.

Finally, special thanks to our Mangalmay Family for the continued support in compiling this volume.

Prof. (Dr.) Tushar Kanti (*Editor*)

Prof. (Dr.) J.N.Giri (*Co-Editor*)

Prof. Harish Bhatia (*Co-Editor*)





**SECTION 1**

**Transforming Business Finances**



# Corporate Social Responsibility: An Analysis of its Tax Implications in Indian Perspective

SRIPAL SRIVASTAVA<sup>1</sup> AND ANJALI DUBEY<sup>2</sup>

## Abstract

*Every economy has its own distinct needs and implications of its revenues. The governance of an economy is fuelled through its revenues. In order to generate sufficient and timely revenues, the revenue department has to be observant enough to synchronise various sectors of the industries through an established framework of different kinds of taxes, duties, cess, surcharges etc. During the whole course of collection, the revenue department has to diligently look for, not only for probable loop-holes of in collection process, but also how the assessments of taxes are made and how the assesses can be allowed certain leverages for doing their part for the good of the society. Here comes the concept of Corporate Social Responsibility for achieving a government's ultimate objective of serving its people. In a way, an assessee spends a certain amount of funds out of its taxable income, for the good of society, taking its responsibility as a corporate entity and thereby the revenue department allows certain relaxations in taxable amount to the assessee. Incidentally, the larger good of the society is achieved.*

*This paper is an analysis of implications of Corporate Social Responsibility in Indian scenario, with a special reference to the mind crunching provisions of the Indian Income Tax Act, 1961 and the Indian Companies Act, 2013*

**Keywords:** *Corporate Social Responsibility (CSR), Assessee, Deductions, Income Tax, Net Profits, Taxable Income, Expenditures, Companies Act*

## INTRODUCTION

It has been said that no one can escape from two things the first one is the Death and the other is Taxation. The Indian Income Tax Act, 1961 has been time and again been quoted as being one of the most delicate as well as most complicated taxation framework.

Before we go deeper in to the depths of Indian Income Tax, let us clear our basis understanding of the term “Corporate Social Responsibility”. As mentioned in the Companies (CSR Policy) Rules 2014, “Corporate Social Responsibility (CSR)” means and includes but is not limited to:

1. Projects or Programs relating to activities specified in Schedule VII of the Act or
2. Projects or Programs relating to activities undertaken by the Board in pursuance of recommendations of the CSR Committee as per the declared CSR Policy subject

---

<sup>1</sup> Assistant Professor, IIMT College of Management, Greater Noida (UP)

<sup>2</sup> Assistant Professor, ABES IT, Ghaziabad (UP)

to the condition that such Policy covers subjects enumerated in Schedule VII of the Act.

### **Applicability of Section 135(1) of the Companies Act 2013**

Every Company whether Private Limited or Public Limited, including its holding or subsidiary & a foreign company having, during any financial year (any of the three preceding financial year):

1. Net Worth of Rs 500 Crores or
2. Turnover of Rs. 1,000 Crores or
3. Net Profit of Rs. 5 Crores.

### **Amount to be Expended on CSR Activities**

1. The company shall spend at least 2% of its Average Net Profit for the immediately preceding three financial years on Corporate Social Responsibility activities.
2. CSR expenditures shall include all expenditures including contribution to corpus but does not include any expenditure on any item not in conformity or not in line with activities which fall within the purview of the Schedule VII of the Act.
3. The list of activities in Schedule VII is illustrative and not exhaustive.
4. CSR Committee with a view to discharge its CSR obligation as arising under section 135 of the Act in the following three ways:
  - (a) making a contribution to the funds as specified in Schedule VII to the Act; or
  - (b) through (NGO) a registered trust or a registered society or a company established under section 8 of the Act by the company, either singly or along with its holding or subsidiary or associate company or along with any other company or holding or subsidiary or associate company of such other company, or otherwise; or
  - (c) in any other way in accordance with the Companies (CSR Policy) Rules, 2014, e.g. suo motto.
5. First preference shall be given to Local Area & Area around it, where company operates;
6. In case of failure to expend the amount on CSR Activities, the Board of Directors shall specify the reason for non-expenditure in the Board's Report.

### **Which Activities shall not be Considered under Corporate Social Responsibility?**

1. CSR projects or programs or activities undertaken in pursuance of its 'normal course of business'
2. CSR projects or programs or activities
  - Carried out as a pre-condition for setting up a business, or
  - As a part of contractual obligation undertaken by the company; or

- In accordance with any other Act; or
  - As a part of the requirement in this regard by the relevant authorities (These activities regarded as normal course of business)
3. CSR Projects or Programs or Activities\
    - Undertaken outside India;
    - That benefit only the employees of the company & their families
  4. Contribution of any amount directly or indirectly to any Political Party (Section 182)

### Composition of CSR Committe

1. Minimum 3 including 1 Independent Director except
  - Private Company o
  - The company which is not required to appoint an Independent Director o
  - Foreign Compan
2. In Case of 2 Directors

<i>Types of Company</i>	<i>Composition</i>
Foreign Company	At least 2 Person , one of them must be Company's Representative
Private Company (Having 2 Director)	2 Directors
Mandatorily not requiring Independent Director	2 Directors
Any other Company (Mandatorily requiring Independent Director) Either listed or not	Minimum 3 including one of them Independent Director

### Consequences of Non-Compliance of Provision

1. If a company contravenes the provision , shall be punishable with fine which
  - Shall not be less than Rs. 50,000/-
  - But which may extend up to Rs. 25,00,000/-, And
2. Every officers of the Company who is in Default, shall be punishable with
  - Imprisonment for a term, which may extend to 3 years or
  - Fine which shall not be less than Rs. 50,000/-
  - But which may extend up to Rs. 5,00,000/- or
  - Both

### Disclosure of CSR

Every company, except foreign company shall disclose the Annual report on CSR, containing particulars specified in the Annexure, in its Board Report and publish in website as well.

In case of Foreign Company, the Balance Sheet file under Section 381(1) (b) shall contain an annexure regarding reporting on CSR.

**Format for the Annual Report on CSR Activities to be included in the Board's Report:**

S No.	CSR Project or Activity Identified	Secto in Which the Project covered	Projects/ programme location (Specify the State and district where project or programm was Undertaken)	Amount Outlay (budget) project or program Wise	Spent on the project or programs	Cumulative Expenditure up to the reporting period	Amo unit spent Direct or Through Imple menting agency
			Local	Other	Direct Expenditure	Through Overhead	

**Meaning of Average Net Profit**

Average Net Profit shall be calculated in accordance with Section 198 of the Companies Act, 2013. Following elements shall not be included while calculating Average Net profit:

- Profit of *Overseas Branch or Branches* of the company,
- Any dividend received from companies in India, which are covered under & complying with the provisions of the Section 135 of the Act.

**Table to Compute Net Profit for CSR Contribution as Per Section 198 of Companies Act, 2013**

	<i>Particulars</i>	<i>Amount</i>
<b>Net profit after tax.</b>		
Net profit after tax is taken as base and accordingly the adjustments need to be considered		
<b>Add :</b>	<b>Allowed Credits</b>	
1.	Bounties and Subsidies received (from any Government, or any public authority constituted or authorised in this behalf, by any Government, unless and except in so far as the Central Government otherwise directs.)	
2.	Profit on sale of immovable property ( Original Cost – WDV )	
<b>Less</b>	<b>Credits Disallowed</b>	
	Profit on sale of forfeited shares	
	Profits of a capital nature including profits from the sale of the undertaking	
	Profit on sale of immovable property (Sale Value of Immovable Property – Original Cost )	
	Surplus in P&L on measurement of asset or liability at fair value	
<b>Less :</b>	<b>Expenses Allowed</b>	
1	All the usual Working Charges	
2	Director's Remuneration	
3	Bonus or Commission paid to Staff	
4	Tax on excess or abnormal profits	
5	Tax on business profits imposed for special reasons	
6	Interest on Debentures	
7	Interest on Mortgage & Secured Loan	

8	Interest on Unsecured Loan	
9	Expenses on repairs ( other than Capital Expenditure )	
10	Outgoings inclusive of Contributions made under section 181 ( Bonafide Charitable Trusts )	
11	Depreciation extent to section 123	
12	Prior period items	
13	Legal liability for compensation or damages	
14	Insurance Expenses	
15	Bad Debt Written off	
<b>Add :</b>	<b>Expenses Disallowed</b>	
1	Income Tax	
2	Compensations, damages or payments made voluntarily	
3	Capital Loss on sale of undertaking or part thereof ( Not include losses on sale of asset )	
4	Expenditure in P&L on measurement of asset or liability at fair value	

#### A) Accounting Treatment

- CSR Expenditure includes Spending as well as Contribution
- CSR is not Charity or mere Donation
- Calculation of CSR spend limit:  
Average profit calculated u/s 198 for last 3 year X 2 % = CSR spend
- Amount unspent or any surplus arising of the CSR activity will not be part of the business profits of company.
- No provision for unspent amount, only disclosure in Board report.
- The excess amount cannot be carried forward for set off against the CSR expenditure required to be spent in future
- If CSR activities has been taken up (in progress) & liability has been incurred (due to contractual obligation), then provisions should be made for such obligation.
- Where a company receives a grant from others for carrying out CSR activities, the CSR expenditure should be measured net of the grant.
- Any surplus arising out of CSR project or programme or activities shall be recognised in the statement of profit and loss and since this surplus can not be a part of business profits of the company, the same should immediately be recognised as liability for CSR expenditure in the balance sheet and recognised as a charge to the statement of profit and loss and such surplus is not form part for calculating limit.

CSR Activities under taken following ways:

- (a) Making contribution: Treated as an expense for the year and charged to the statement of profit and loss.
- (b) Through others': Treated as an expense for the year and charged to the statement of profit and loss.
- (c) Any other way on its own:



***In Nature of Capital Expenditure***

CSR is a Capital Expenditure if such expenditure meets the definition of an Assets According to present Accounting Standard, an asset is a resource controlled by enterprises as a result of past events, and from which future economic benefits are expected to flow to enterprises. Depreciation of such an asset can be claimed as CSR expenditure only if the expenses incurred on creation of assets are not claimed as CSR expenditure.

- (i) in cases where the control of the 'asset' is transferred by the company, e.g., a school building is transferred to a Gram Panchayat for running and maintaining the school, it should not be recognised as 'asset' in its books and such expenditure would need to be charged to the statement of profit and loss as and when incurred
- (ii) In other cases, where the company retains the control of the 'asset' then it would need to be examined whether any future economic benefits accrue to the company.

Invariably future economic benefits from a 'CSR asset' would not flow to the company as any surplus from CSR cannot be included by the company in business profits.

***In Nature of Revenue Expenditure***

CSR is revenue expenditure if company has incurred expenditure on the activities specified under Schedule VII of Companies Act, 2013. If CSR expenditure related to business of the entity then such expenditure should be treated as an expense in the statement of profit and loss. Where a company receives a grant from others for carrying out CSR activities, the CSR expenditure should be measured net of the grant.

Company may supply goods manufactured by it or render services as

- (a) the expenditure incurred should be recognised when the control on the goods manufactured by it is transferred or the allowable services are rendered by the employees.
- (b) The goods manufactured by the company should be valued in accordance with the principles prescribed in Accounting Standard.
- (c) The services rendered should be measured at cost.
- (d) Indirect taxes on the goods and services so contributed will also form part of the CSR expenditure

***In Nature of Appropriation***

CSR expenditure is not related to the business of the entity then such an expenditure should be treated as an appropriation of profit.

**Presentation in Financial Statement**

- (a) All expenditure on CSR activities, that qualify to be recognised as expense should be recognised as a separate line (Separate Ledger Head) item as 'CSR expenditure' in the statement of profit and loss. Further, the relevant note should disclose the

break-up of various heads (Functional Head) of expenses included in the line item 'CSR expenditure'

- (b) The notes to accounts relating to CSR expenditure should also contain the following:  
 1. Gross amount required to be spent by the company during the year. 2. Amount spent during the year on:

<i>S. No.</i>	<i>Particular</i>	<i>In Cash</i>	<i>Yet to be Paid in Cash</i>	<i>Total</i>
(i)	Construction/acquisition of any asset			
(ii)	On purposes other than (i) above			

The above disclosure, to the extent relevant, may also be made in the notes to the cash flow statement, where applicable.

- (c) Details of related party transactions, e.g., contribution to a trust controlled by the company in relation to CSR expenditure  
 (d) Where a provision is made same should be presented as per the requirements & movements in the provision during the year should be shown separately.

## **B) Taxation Matter**

MCA does not come out with the clear guideline regarding tax treatment of CSR expenditure but there may be one possible solution for tax incentive of CSR expenditure is with the compliance of scope of CSR activity of schedule VII should be expanded so as it include activity which consider as social activity & also related to business for getting Best benefit to Income tax.

According to Explanation 2 of the Finance (No.2) Act, 2014.

“any expenditure incurred by an assessee on the activities relating to corporate socialresponsibility referred to in section 135 of the Companies Act, 2013 (18 of 2013) shall not be deemed to be an expenditure incurred by the assessee for the purposes of the business or profession.”

One side it is mandatory to spend money on CSR as per Companies Act,2013 and on the other side the same is disallowed under the Income Tax Act, 1961, the CSR policy should be formulated by the CSR Committee in such a manner as to require CSR expenditure to be incurred on such activities as laid down in Schedule VII that are also eligible for deduction under sections 30 to 36 of the IT Act, it would facilitate companies in complying with the CSR obligations under the Companies Act, 2013 as well as in availing of the tax benefit under the Income Tax Act, 1961.

Following are summary of the present admissible tax exemption/deduction that can be avail regarding CSR spending.

S. No.	Specific CSR Activities Referred under Schedule VII to the 2013 Act	Expenditure Allowed under the Relevant provisions of the Income-Tax Act, 1961
I	Activities concerning Basic necessities of Life	More than prescribed layers of subsidiaries
	– Eradication of poverty, hunger and malnutrition	Section 35AC read with Rule 11K(i)(f) of Income-tax Rules, 1962 ('the 1962 Rules')
	– promoting health care including preventive health care and sanitation including contribution to the Swach Bharat Kosh set-up by the Central Government for the promotion of sanitation and making available safe drinking water	Section 35AC r.w. Rule 11k(i)(a),(f),(j) of the 1962 Rules 80G(2)(iiihk)
II	Activities concerning Education	
	– Promoting Education, including special education and employment enhancing vocational skills especially among children, women and elderly and the differently able	Section 35AC r.w. 11K(i)(c),(i),(o),(p),(s) of the 1962 Rules
III	Activities addressing inequality and gender discrimination	Section 35AC r.w. Rule 11K(i)(n),(i) of the 1962 Rules
	– Promoting gender equality	
	– Empowering women	
	– Setting up of homes and hostels for women and orphans	
	– Setting up old age homes, day care centre and such other facilities for senior citizens and – Measures for reducing inequalities faced by socially and economically backward groups;	
IV	Activities concerning Care for environment	Section 35AC r.w. Rule 11K(i) (d),(h),(l),(q),(r) of the 1962 Rule & 80G(2)(iiihl)
	– Ensuring environmental sustainability and ecological balance	
	– Protection of flora and fauna, animal welfare, agro forestry	
	– Conservation of natural resources and maintaining quality of soil, air and water including contribution to the Clean Ganga Fund set-up by the Central Government for rejuvenation of river Ganga.	

<i>S. No.</i>	<i>Specific CSR Activities Referred under Schedule VII to the 2013 Act</i>	<i>Expenditure Allowed under the Relevant provisions of the Income-Tax Act, 1961</i>
V	Activities concerning protection of National Heritage, Art and Culture – Protection of national heritage, art and culture including restoration of building and sites of historical importance and works of art – Setting up public libraries – Promotion & Development of traditional arts and handicrafts	Section 35AC r.w. Rule 11K(The notification issued under the Act in the past have accepted the said activities for deduction u/s. 35AC [except with no precedent available for protection of national heritage u/s. 35AC, but deduction could be claimed in Section80G(2)(b)
VI	Activities concerning benefit to Armed Forces, veterans, war widows and their dependants	
	– Measures for the benefit of armed forces, veterans, war widows and their dependents	Section 80G(2)(a)(i) and 80G(2)(a)(iii)(h)(c)
VII	Activities concerning Sports	
	– Training to promote rural sports, nationally recognised sports, Paralympics sports and Olympic sports	Section 35AC r.w. Rule 11K(i)(g)
VIII	Activities concerning national relief and welfare of Economically backward class of Society	
	– Contribution to PM National relief fund or any other fund set up by the Central Government for socio-economic development	Section 80G(2)(a)(iiia)
	– Relief and welfare of the Schedules Casts, Schedules Tribes, Other backward castes, minorities and women	Section 35AC r.w. Rule 11K(i)(b),(c) and Rule 11K(ii) of the Income-tax Rules
IX	Activities concerning Technology incubators	
	– Contributions or funds provided to technology incubators located within academic institutions which are approved by Central Government	Section 35(2AA) and Section 80G(2) (iihi) [considering limited information available and provided on the subject, it will have to be determined as to whether the aforesaid section shall be able to provide deduction to the activities concerned]

<i>S. No.</i>	<i>Specific CSR Activities Referred under Schedule VII to the 2013 Act</i>	<i>Expenditure Allowed under the Relevant provisions of the Income-Tax Act, 1961</i>
X	Activities concerning Rural Development	
	– Rural Development Projects	Section 35AC and Section 35CCA [with limited information available and provided on the term referred to as ‘rural development projects’ therefore, either of the provisions may be considered for allowability of expenditure]
XI	Activities concerning Slum Area Development	
	– Slum Area Development Explanation.—For the purposes of this item, the term ‘slum area’ shall mean any area declared as such by the Central Government or any State Government or any other competent authority under any law for the time being in force.	

### **In Summary**

<i>S. No.</i>	<i>Section</i>	<i>Nature</i>
1	35	Deduction of Expenditure on Scientific Research Capital as well as Revenue Exp.
2	35AC	Expenditure on Eligible Projects or Schemes
3	35CCA	Payments to Association & Institution for Carrying out Rural
4	35CCD	Expenditure on skill development project notified by the board
5	36(1)(ix)	Applicable to Company who incurs expenditure on promotion of family planning amongst employees Revenue as well as capital expenditure
6	80G	Donation to certain Funds & Institutions
	80GGA	Deduction in respect of donation to scientific research or rural development section

As per income tax ,Contribution to Swachh Bharat Kosh 80G(2)(iihk)&Clean GangaFund 80G(2)(iihl) must be other than CSR u/s 135 of Companies act.

It has been explained by the CBDT in the circular no. 1/2015 Dated 21/1/2015:

“CSR expenditure, being an application of income, is not incurred wholly and exclusively for the purposes of carrying on business. As the application of income is not allowed as deduction for the purposes of computing taxable income of a company, amount spent on CSR cannot be allowed as deduction for computing the taxable income of the company. Moreover, the objective of CSR is to share burden of the Government in providing social

services by companies having net worth/turnover/profit above a threshold. If such expenses are allowed as tax deduction, this would result in subsidizing of around one-third of such expenses by the Government by way of tax expenditure.”

#### **A few relevant cases in reference to Corporate Social Responsibility**

- **Krishna Sahakari Sakhar Karkhana Ltd v CIT:** Payment to an Education Fund of the State Federal Society as required u/s 68 of the Maharashtra Co-operative Society Act
- **CIT v Andhra Bank:** Spent on Andhra Bank Rural Development Trust which is engaged in conducting several training for providing self employment to rural youth and after the training, the bank also provided finance to rural youth.

#### **Confusion and Vague Interpretation of Law**

**CIT v. Infosys Technologies Ltd :** Allowed the expenditure incurred for installing traffic signal by company under social initiative by the reason of the said signal used by its employee as it relates to business activity hence allowed u/s 37(1)

However, in the Case of **CIT v. Wipro Ltd:** Expenditure for community development near its factory, the court does not find any nexus for its business activity hence disallowed such expenditure u/s 37(1)

**CIT v DTTDC Ltd:** Where the income is utilized for self-imposed obligation, it signifies “Application of Income” whereas obligation where money flows out of an independent title signifies “Diversion of Income.” However, Explanatory Memorandum to the Bill it is stated that CSR expenditure is an application of Income. Here, one question raised, whether one can claim the deduction of CSR u/s 37(1) up to the amount which is necessarily required to be expended u/s 135 of companies act, 2013, on the ground that it is diversion of income by successfully substantiating that the same has been expended because of mandate by the Companies Act, 2013 and not because of self-imposed.

#### **MAT**

While computing Book Profit u/s 115JB of the Income Tax Act relating to Minimum Alternative Tax (MAT) the CSR expenditure should not be considered as a below the line item meanwhile same would not be allowed under normal provision of income tax act. Hence, the Book Profit to be computed u/s 115JB of the Act should not be increased by the expenditure incurred on CSR i.e. No Adjustment for CSR u/s 115JB

#### **CONCLUSION**

According to research done by EY, the CSR-spending stipulation is likely to apply to at least 2,500 companies. Money spent on activities including eradication of extreme hunger, promotion of education and gender equality, reduction of child mortality and improvement of maternal health, environment sustainability, social business projects, employment enhancing vocational skills, sanitation, promotion of sports and games, welfare activities

for the disabled and old, setting up model villages, scholarships and combating HIV and AIDS, is likely to be made permissible to be counted under CSR expenditure.

Irrespective of the complicated regulations and provisions of Indian Income Tax Act, 1961 and the Indian Companies Act, 2013, the Corporate Social Responsibility has taken a solid ground and its true potential is yet to be charted. It should be realised with utmost caution and diligence that CSR expenditures are not a getaway or an alternative for tax avoidance and tax evasion, rather it's an imperative economic tool to reach out for the greater good of the society at large.

#### **BIBLIOGRAPHY**

- [1] Income Tax Act, 1961
- [2] Companies Act, 2013
- [3] [www.icai.org](http://www.icai.org)
- [4] [www.ey.com](http://www.ey.com)
- [5] [www.taxguru.in](http://www.taxguru.in)
- [6] [www.taxesutra.com](http://www.taxesutra.com)
- [7] [www.livemint.com](http://www.livemint.com)

# Benefits of GST for Startup Business in India?

RASHMI GUJRATI <sup>1</sup>

## Abstract

According to **Kautilya** in his book "Arathshashtra" the tax system of a country should be "liberal in assessment and ruthless in collection".

One of the major steps on this tax reform is introduction of Goods and Service tax. The GST (Goods and Services Tax) is a planned system of countrywide VAT which will be uniform for goods and services transactions in India. The VAT is a type of consumption tax that is placed on a product whenever value is added at a stage of production and at final sale. It is charged at each stage of chain including production and distribution from raw materials to the final sale of finished product based on the value added at each stage. In this system the full brunt is borne by the end consumer.

GST would bring in important change in doing business in India. Advocacy for best practices, gearing up for changes in developments, training teams and developing IT systems for being GST yielding are the key areas to be evaluated. The Government is committed to introduce GST by April 2017. Tax payers need to be GST compliant to be able to test system changes in time. Depending on the operating geographies, size and sector, the changes would be extensive and may require practical planning with a time-bound action plan. In order to prepare for the implementation of GST, companies need to understand GST policy development and its implications for scenario planning and transition roadmap preparation. The main objective of Tax reforms is to establish a tax system that is economically effective and impartial in its application, distributionally attractive, and simple to administer.

**Keywords:** Arathshashtra, Liberal, Goods and Service Tax, Geographies, Development, Distributional

## INTRODUCTION

The GST is recommended by the Kelkar Task Force on implementation of the Fiscal Responsibility and Budget Management (FRBM) Act, 2003. According to them the existing system of taxation of goods and services still suffers from many problems. The tax base is fragmented between the Centre and the States. Services, which make up half of the GDP, are not taxed appropriately. In many situations, the existing tax structure has cascading effects. These problems lead to low tax-GDP ratio, besides causing various distortions in the economy. The effort to introduce the new tax regime was reflected, for the first time, in 2006-2007 Union Budget Speech by Finance Minister. He proposed 1st April 2010 as the date for introducing GST, and in same fashion he set some more deadlines.

---

<sup>1</sup> Professor, GGSIP University Dwarka, New Delhi  
E-mail: e-drrashmi\_gujrati@yahoo.com



“Goods and Services Tax” would be a comprehensive indirect tax on manufacture, sale and consumption of goods and services throughout India, to replace taxes levied by the Central and state governments. The entire nation is set to benefit by GST in total, but start-ups can be more pioneer and ground breaking in their business models. GST will help to build more favorable conditions for business houses to do business in India.

### **OBJECTIVE OF THE STUDY**

The main objective of Tax reforms is to establish a tax system that is economically effective and impartial in its application, distributionally attractive, and simple to administer.

It is aimed at being comprehensive for most goods and services

### **RESEARCH METHODOLOGY**

The methodology of this research is based on secondary data.

### **LITERATURE REVIEW**

In 2000, the Vajpayee Government set up an Empowered Committee of State Finance Ministers headed by Asim Dasgupta, Minister of Finance and Excise of West Bengal to frame the model of Value Added Tax (VAT). The aim was to do away with the existing national-level central excise duty and state-level sales tax. When UPA Government came to power, an announcement was made by the then Union Finance Minister Mr. P. Chidambaram during the budget session of 2006-07 on February 28, 2006, that GST would be introduced from April 1, 2010. The salient features about this legislation were first time discussed in its first discussion paper in year 2009. But the GST Bill endured in abeyance for one or other reason till it was re-introduced in 2014 by Modi Government with a new draft suggestion.

#### **What is GST?**

The biggest indirect tax reform since 1947, GST bill is expected to bring about an economic incorporation of the Indian economy. GST will help merge and modernize the process of indirect taxation and make it easier and more effective. The tax payers will pay one merged tax instead of the surplus of taxes including State Value-Added Tax (VAT), Central Excise, and Service Tax, Entry Tax or Octroi and a few other indirect taxes. “The challenges faced due to a complicated tax system on business transactions have been debated for a long time,” said R Narayan, Founder and CEO, Power 2SME. This tax will be imposed on manufacture, sale and consumption of goods as well as services at the Central and State government levels. “The distinction between Goods and Services will be reduced gradually, thereby making tax compliances easier,” he added. Most of the developed countries use this form of taxation for ease and suitability and to avoid double taxation.

GST would be payable on price really paid or payable, termed as «transaction value», which will contain packing cost, commission, and all other expenses suffered for sales. This tax will be payable at the final point of the consumption. The GST will have two components – the Central GST and the State GST, thus, empowering both the State and

Central government to legislate and administer their respective taxes. Except the Tamil Nadu government, which believes that this bill will take away the autonomy of the State government, all other States are in support of the bill. The greatest indirect tax change subsequent to 1947, GST bill is relied upon that will bring an economic integration of the Indian economy. GST will merge and streamline the procedure of indirect taxation and make it easier and more powerful. The citizens will pay one merged expense rather than the plenty of taxes including State Value-Added Tax (VAT), Central Excise, Service Tax, Entry Tax or Octroi and a couple of other indirect taxes.

### **Why are startups and SMEs so excited about GST?**

GST is deemed to benefit all businesses in India, but small businesses can rejoice for the following reasons:

1. *Ease of starting business:* Any new business needs to have a VAT registration from sales tax department. A business operating in many States has to face a lot of issues concerning the different processes and fees in each state. GST will bring about a uniformity in process and centralized registration that will make starting business and expanding in different States much simpler.
2. *Higher exemptions to new businesses:* As per the current gathering, any business with a turnover of more than Rs. five lakh has to get VAT registration and pay VAT. GST will make this limit higher, to up to Rs. 10 lakh and, further to it, businesses with turnover between Rs. 10 and 50 lakh will be taxed at lower rates. This will bring relief from tax burdens to newly reputable businesses.
3. *Simple taxation:* Currently, a startup spends a lot of time and energy to manage the various taxes at various points. Adhering to different regulations at different States make the process very complex. GST will simplify the process by integrating all taxes, making the process of paying tax simpler.
4. *Respite for businesses in both sales and services:* Businesses like restaurants, which fall under both sales and service taxation, have to calculate the VAT and service tax on both items separately. This makes the calculations process very complex. GST will not distinguish between sales and services, and thus the tax calculation will be done on total.
5. *Reduction in logistics cost and time across States:* Many transport vehicles get delayed during movement across States due to small border tax and check post issues. Interstate movement will become cheaper and less time consuming, as these taxes will be removed. “The whole Indian market opens up for manufacturers as interstate supply becomes tax-neutral,” explained Narayan. This will also bring down costs associated with maintaining high stocks, as there will be uninterrupted movement of goods. As per a CRISIL analysis, GST can reduce logistics costs of companies producing non-bulk goods (comprising all goods besides the primary bulk commodities transported by railways - coal, iron ore, cement, steel, food grains, and fertilizers) by as much as 20 percent.

**GST Advantages for Startups**

1. The production and distribution of goods and services are constantly increasingly due to emerging Indian market locally and globally. A single taxation system would encourage new businesses and entrepreneurs to engage in service and manufacturing sector.
2. The significant aspect of GST is that this tax will be imposed only on the final purpose or on consumption of goods or services t on the value added (addition of value would be the taxable event. This helps to eliminate economic alterations in taxation amongst states and helps in the free movement of goods.
3. GST also seeks to reduce discretion exercised by the assessing authority. This means a more transparent taxation system with less corruption. Hence, better opportunities for new businesses.
4. The tax is imposed on only finished product movement and not at every stage of production or distribution the complexity of taxation is sought to be removed by this.
5. Individuals will get benefit out of it as the prices will go down due to GST and decrease in price means increase in consumption. This increase in consumption will make the manufacturing industry to produce more and thereby directly helping in an increase in GDP.
6. Since the same tax implementation will be made in all states and for all types of businesses, they need not struggle due to lack of policy or any unidentified norms of the taxation laws.
7. Easing governing norms will not only benefit the new age businesses like e-commerce but also helps to attract more foreign investments from global markets which in turn will create more employment opportunities.
8. The ease of starting up a business in India will further encourage entrepreneurs to enter into the manufacturing and industrial sector. Currently several registrations such as VAT registration, CST registration, import/ export registration to get duty benefits are made. But eventually, after implementation of GST, this will be removed.

Several other indirect benefits for both government and business enterprises could also be achieved such as:

1. Exclusion of delay due to transportation of goods. Regularity in taxation throughout states will ensure clearances are done quickly.
2. The overhead cost of the goods will be reduced by the time goods reaches to the consumer.
3. The costs to maintain chain of supply of goods will be significantly reduced for the business organization.
4. The business-friendly tax will play a vital role to boost new startups in India.

Overall, for the country to come out of its multifaceted taxation laws and to boost new entrepreneurs and startups in India the application of GST could be a step towards

achieving that goal. The enterprise of the current government to make the startups tax free for three years is a step towards encouraging the Major scheme i.e. Make in India.

### **GST Bill: How it Affects Our Life**

It now looks that the GST Bill might get safe passage as the Congress has agreed to a debate on the bill and other political parties also show feeling to support the GST bill. GST, one of the biggest taxation reforms in India is inclusive tax charge on manufacture, sale and consumption of goods and services at a national level. A right step to move forward with the 'Make in India' vision application of GST will get rid of multi-tier and multiple taxation system in the country.

### **What is GST Bill?**

The Goods and Services Tax Bill or GST Bill, officially known as The Constitution (122nd Amendment) Bill, 2014, proposes a national Value Added Tax to be implemented in India. GST stands for "Goods and Services Tax", and will replace all indirect taxes charged on goods and services by the Indian Central and State governments. It is aimed at being comprehensive for most goods and services

### **GST Bill: Key Points Affecting Common Life**

Purpose based Indirect Tax GST would be a target based tax as against the present concept of origin based tax. It is going to replace all indirect taxes imposed on goods and services by the Indian Central and State governments.

### **Single Taxation: No Multiplicity**

As multiple taxes on a product or service are removed and a single tax comes into place, the tax structure is expected to be much simpler and easier to understand. Flow of goods would be much smoother as the transporting of goods would be possible without disruption from place of origin to place of destination.

### **Win-Win Situation for Centre, State and Goods & Service Industry**

GST Bill would replace the taxes collected by Central Government on Goods and Services such as Central Excise duty, Duties of Excise (Medicinal and Toilet Preparations), Additional Duties of Excise (Goods of Special Importance), Additional Duties of Excise (Textiles and Textile Products), Additional Duties of Customs (commonly known as CVD), Special Additional Duty of Customs (SAD), Service Tax, Cesses and surcharges. On the sides of the States, GST would replace State VAT, Central Sales Tax, Luxury Tax, Entry Tax (other than those in lieu of Octroi, Entertainment Tax, Taxes on advertisements, Taxes on lotteries, betting and gambling , State cesses and surcharges in so far as they relate to supply of goods or services.

**Will Simplify Taxation**

The implication of GST bill promises a single taxation system in the whole country for all goods and services making tax obedience easier and more effective. This will simplify India's tax structure, broaden the tax base, increase the income and create a common market across states. According to a report by the National Council of Applied Economic Research, GST is expected to increase economic growth by between 0.9 per cent and 1.7 per cent.

**BENEFICIAL TO ALL**

Corporate and manufacturing sectors will get following benefits with the implementation of GST bill:

- Average tax burden on companies will fall.
- Reducing production costs will make exporters more competitive.
- The reduced cost of locally manufactured goods and services will increase the competitiveness of Indian goods and services in the international market and give boost to Indian exports.
- Manufacturing sector in India is one of the highly taxed sectors in the world. GST bill when enforced would removedifficulties in the present taxation structure and therefore prevent the loss of nearly 50% of the advantage of lower manufacturing costs that India has over the western nations.
- The individual will benefit from lowered prices in the process which will afterward lead to increase in consumption thereby profiting companies.

**Can GST Bill Become Act Now?**

The chances are more as the Government appears to be in mood to accept most of the modification demand from opposition in GST bill proposal. The only stranglehold according to the Government is that it is not advisable to list the cap of 18% in constitution as specifying a tax rate in the constitutional change would need amending the constitution every time when the rate is changed.

**Impact of GST in Indian Economy – GST Impact in India**

Among economic crisis across the globe, India has stood as a inspiration of hope with ambitious growth targets, supported by slide of strategic missions like 'Make in India', 'Digital India', etc. Goods and Services Tax (GST) is expected to provide the much needed stimulant for economic growth in India by transforming the current basis of indirect taxation towards free flow of goods and services within the economy and also removing the flowing effect of tax on tax. In view of the important role that India is expected to play in the world economy in the years to come, the probability of GST being introduced is high not only within the country, but also in neighboring countries and in developed economies of the world.

- Reduce tax burden on manufacturers and substitute growth through more production. This double taxation prevents manufacturers from producing to their best capacity and delays growth. GST would take care of this problem by providing tax credit to the manufacturer.
- Various tax barriers such as check posts and toll plazas lead to a lot of wastage for consumable items being transported, a loss that translated into major costs through higher need of buffer stocks and warehousing costs as well. A single taxation system could remove this roadblock for them.
- A single taxation on manufacturers would also translate into a lower final selling price for the consumer.
- Also, there will be more transparency in the system as the customers would know accurately how much taxes they are being charged and on what base.
- GST would add to government proceeds by spreading the tax base.
- GST provides credits for the taxes paid by producers earlier in the goods/services chain. This would inspire these producers to buy raw material from different registered dealers and would bring in more and more vendors and suppliers under the purview of taxation.
- GST also removes the custom duties applicable on exports. Our competitiveness in foreign markets would increase on account of lower cost of transaction.
- The proposed GST regime, which will subsume most central and state-level taxes, is expected to have a single unified list of concessions/exemptions as against the current mammoth exemptions and concessions available across goods and services.

## **CONCLUSION**

The ruling government and various states are positive for the GST and believe it will help the news businesses and startup in a possible manner. Critics of GST argue that implementation of this tax will lead to losing the fiscal autonomy of the States and cause permanent revenue loss. Also, the government could not bring complete amendment in the bill. The separate State and Central GST system will not completely eliminate the irregular and double taxation problem and only bring it down, The States will be presenting their policies in the upcoming monsoon session, thus it remains to be seen how uniform these policies will turn out to be.

## **REFERENCES**

- [1] Consumer, SME loan market to reach \$3 trillion in 10 years: Report.
- [2] GST will slice up to 20% of logistics costs CRISIL.
- [4] Draft law proposes to bring e-commerce under GST Times of India.
- [5] How will the GST impact your startup business Your Story.
- [6] 5 reasons why GST may not be all that it is cracked to be First Post.
- [7] Budget 2016: GST will bring in clarity, boost e-commerce in India says IMAI Economic Times.
- [8] GST to enhance SMEs' efficiency Business Standard.

- [9] Small and medium enterprises want friendlier GST Bill Deccan Chronicle.
- [10] All you need to know about the GST Constitutional Amendment Bill|Business Chronicle.
- [11] How GST Will Change the Face of Indian Economy NDTCProt.
- [12] GST: Your 10-Point Guide to a Landmark Tax Reform NDTCProt.
- [13] See GST bill getting passed, but its benefits will accrue only over time: C Jayaram, Kotak Mahindra Bank xiii. Banking on reforms: RBI's new norms can help promote efficient lending practices.
- [14] PTI, GOI press releases.

# Technology Upgradation on the Functioning of Indian Banking Sector

ANASHUL SHARMA<sup>1</sup> AND SOMEH KUMARZ<sup>2</sup>

## Abstract

*Indian Banks have recorded a phenomenal growth in the past decade with the initiation of Economic Reforms. The banks, both Public and Private, have transformed themselves into profit-oriented business organizations besides playing a developmental role in the economy. In an attempt to be more profitable, the banks have become competitive and more customer-oriented. This new orientation has compelled them to take a more pragmatic approach for conducting the business. Innovation is the key to success for any activity and technology has become the fuel for rapid change. Innovative banking is possible only when we have innovative people in banking. Moreover, innovative ideas of such people have to be heard at the right time by the right people. Only then the needed encouragement and support is given to convert innovative ideas into reality. Indian banking is also changing its shape rapidly by adopting innovative technology products and services.*

*The new technology has radically altered the traditional ways of doing banking business. Technology plays a prime role in improving the internal working of a bank and ensuring customers' satisfaction. It has accelerated Customer –Centric delivery channels services round the clock.*

*The paper focus on new and upcoming technology in banking sector, trends in technology development, tools applicable in banking, impact on service quality of banks etc.*

**Keywords:** Trends in Technology Development, ATM, Overseas Operation of Indian Banks, Impact of Technology on Banking

## INTRODUCTION

Technology has given new dimension to the banks service delivery mechanism and the banks are enthusiastically absorbing the latest technological innovations for devising new products and services. India's banking system has several outstanding achievements to its credit, the most striking of which is its reach. Banking industry provides financial services to the customers such as acceptance of deposits, giving loans, providing facilities for transfer of funds, giving financial guarantees, providing foreign exchange facilities etc. All these services are basically information processing services. Indian banks are spread out into the remote corners of our country. In terms of the numbers of branches, Indian's banking system is one of the largest and even more significant achievement is the close association of India's banking system with its development efforts. The advent of information technology has changed the way in which the data are processed. Therefore, almost all

---

<sup>1</sup> Professor, IIMT Group of Institutions

<sup>2</sup> Associate Professor, IIMT Group of Institutions



services provided by the banks including the concept of money or credit are influenced by the information technology thereby opening new opportunities. The customers are doing business with their banks from the comfortable confines of their homes or offices. They can view the accounts, get accounts statements, transfer funds, purchase drafts by making a few key punches. With the availability of ATMs and plastic cards, they can avoid to a large extent going to the branch premises. Cards with an embedded micro-processor chip (smart cards) are adding a new dimension to this scenario. EDI is another development that has made its impact felt on the banking industry. In this industry, IT used in five key areas:

1. Convenience in product delivery access
2. Managing productivity access
3. Product design
4. Adapting to market and customer needs
5. Access to the customers market

### SCOPE OF THE STUDY

The banking industry in India is undergoing a major transformation due to changes in economic condition and continuous deregulation. These multiple changes happening one after another has a ripple effect on a bank trying to graduate from completely regulated sellers market to completely deregulated customers market.

- *Deregulation*:-This continuous deregulation has made the banking market extremely competitive with greater autonomy, operational flexibility, and decontrolled interest rate and liberalized norms for foreign exchange. The deregulation of the industry coupled with decontrol in interest rates has led to entry of a number of players in the banking industry. At the same time reduced corporate credit of thanks to sluggish economy has resulted in large number of competitors battling for the same pie.
- *New Rules*:-As a result, the market place has been redefined with new rules of the game. Banks are transforming to universal banking, adding new channels with lucrative pricing and freebies to offer. Natural fall out of this new players, new channels squeezed spreads, demanding customers better service, marketing skills heightened competition, new rules of the game pressure on efficiency missed opportunities. Need for new orientation diffused customer loyalty. Bank has led to a series of innovative product offerings catering to various customer segments, specifically retail credit.
- *Efficiency*:-This in turn has made it necessary to look for efficiencies in the business. Bank need to access low cost funds and simultaneously improve the efficiency. The banks are facing pricing pressure, squeeze on spread and have to give thrust on retail assets.
- *Diffused Customer Loyalty*:-This will definitely impact customer preferences, as they are bound to react to the value added offerings. Customers have become demanding and the loyalties are diffused. These are multiple choices; the wallet share is reduced per bank with demand on flexibility and customization. Given the

relatively low switching costs; customer retention calls for customized service and hassle free, flawless service delivery.

- *Misaligned Mindset*:-These changes are creating challenges, as employees are made to adapt to changing conditions. There is resistance to change from employees and the seller market mindset is yet to be changed coupled with fear of uncertainty and control orientation. Acceptance of technology in but the utilization is not maximized.
- *Competency Gap*:-Placing the right skill at the right place will determine success. The competency gap needs to be addressed simultaneously otherwise there will be missed opportunities. The focus of people will be doing work but not providing solutions, on escalating problems rather than solving them and on disposing customers instead of using the opportunity to cross sell.

### **OBJECTIVES OF THE STUDY**

This research paper intends to investigate technology upgradation in the banking sector and its impact on various fields. The objectives of the study are as follows:

1. To identify the latest technology available in banks
2. To identify the use and impact of the technology
3. To find out how it is beneficial as compared to the previous technology

### **RESEARCH METHODOLOGY**

The information is collected on the basis of secondary data and from various banking journals, websites, magazines, libraries, etc .It focuses on the growth of the technology in the banking sector and what segment of the society it has covered ,how technology is being upgraded and what more is about to come.

### **HYPOTHESIS**

1. Information Technology facilitates wide and speedy services to banking services.
2. Private and Foreign banks use more Information Technology related banking services than public banks
3. Impact of technology on efficient low cost data communication is across all banks
4. The public sector banks are on the path of technology upgradation

### **RESEARCH DESIGN**

Descriptive Research is used in accomplishing the objectives of the study.

### **TRENDS IN TECHNOLOGY DEVELOPMENT**

The advancement in software tools ,computer hardware and telecommunication have shifted the focus of the banks towards computerization from data processing to information services .The trend is toward shared satellite based communication systems and networking technologies.

Technology adopted by the Banks is:-

1. Data Warehousing and Data Mining
2. Electronic Data Interchange
3. Corporate Web Sites
4. Management Information System.

### **Current Tools Applicable in Banking**

There is different tools use in banks-

1. Micr/Ocr Clearing System
2. Debit Clearing System
3. Real Time Gross Settlement
4. Structured Financial Messaging System
5. Credit Cards
6. Debit Cards
7. Smart Cards
8. Atm
9. Remote Banking Services
10. Internet Banking
11. Electronic
12. Electronic Credit Clearing
13. Electronic Debit Clearing
14. Tele-Banking- Atm
15. Electronic Cheques
16. Cheque Truncation

### **Latest Upcoming Technologies in Banks**

1. Rural ATMs
2. Biometric ATMs for Rural India
3. Check Truncation Kiosk
4. Biometric Smart Cards
5. “SBI Tiny” the No Frills Account for Rural Indians
6. Mobile Banking
7. Mobile Phone Banking

### **SUMMARY AND FINDINGS**

I summarized the data and find how technologies play a vital role in our banking sector. So I categorized data according to fact and findings .The following result came:

**ATM**

During 2008-09, the total number of ATMs installed by the banks grew by 25.4 per cent, with number of ATMs of SBI Group registering a sharp growth of 34.5 per cent. While, the ATMs installed by new private sector banks and foreign banks were more than 3 times of their respective branches, the ATM to branch ratio was much lower for other bank groups.

**Table 1:** Computerisation in Public Sector Banks  
(As at end-March)

Category		2008	2009	% change
Fully Computerised Branches (i+ii)		93.7	95.0	(+)1.3
i)	Branches Under Core Banking Solution	67.0	79.4	(+)12.4
ii)	Branches already Fully Computerised #	26.6	15.6	(-)11
Partially Computerised Branches		6.3	5.0	(-)1.3
#: Other than branches under Core Banking Solution.				

Source:-www.rbi.org.in

**Table 2:** Branches and ATMs of Scheduled Commercial Banks  
(As at end-March 2009)

Bank Group		Number of Bank/Branches				
		Rural	Semi-urban	Urban	Metro-politan	Total
i	Nationalised Banks	13,381	8,669	8,951	8,375	39,376
ii	State Bank Group	5,560	4,835	3,043	2,624	16,062
iii	Old Private Sector Banks	842	1,554	1,344	933	4,673
iv	New Private Sector Banks	271	1,084	1,371	1,478	4,204
v	Foreign Banks	4	4	52	233	293
Total (i to v)		20,058	16,146	14,761	13,643	64,608

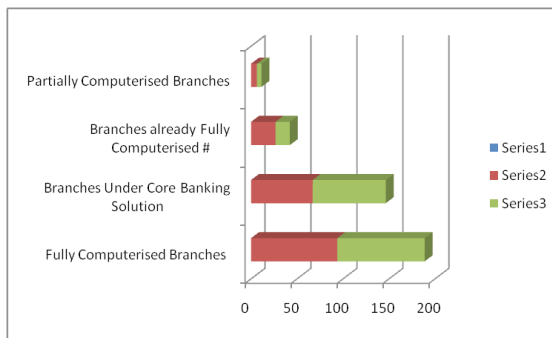

**Table 3: Branches and ATMs of Scheduled Commercial Banks (As at end-March 2009)**

Bank Group		Number of ATMs			Off-site ATMs as % age of total ATMs	ATMs as % age of Branches
		On-site	Off-site	Total		
i)	Nationalised Banks	10,233	5,705	15,938	35.8	40.2
ii)	State Bank Group	7,146	4,193	11,339	37.0	29.0
iii)	Old Private Sector Banks	1,830	844	2,674	31.6	56.9
iv)	New Private Sector Banks	5,166	7,480	12,646	59.2	296.6
v)	Foreign Banks	270	784	1,054	74.4	357.3
Total (i to v)		24,645	19,006	43,651	43.5	67.0

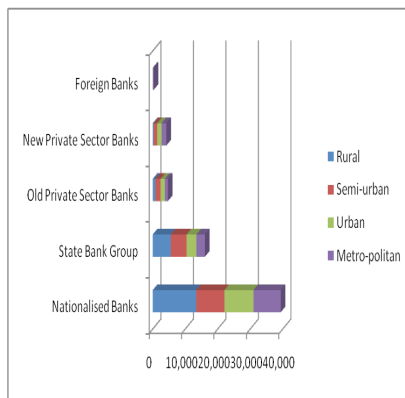

### Overseas Operation of Indian Banks

Indian banks continued to expand their presence overseas. According to table chart, Even though Bank of Baroda has largest overseas presence, State Bank of India also increased its operations overseas significantly during the year. During the year 2008-09, the total assets of the overseas branches increased by USD 6,570 million (10.9 per cent), and stood at USD 67,129 million as on March 31, 2009. The growth in assets was mainly contributed by net increase in customer credit by USD 5,988 million during the year. The asset growth had been largely funded by inter-branch borrowings and customer deposits, which had gone up by USD 2,906 million (121.8 per cent) and USD 2,107.44 million (10.4 per cent) and stood at USD 5,293 million and USD 2,2376 million respectively as on March 31, 2009.

### Impact of Technology on Banking

Indian banks used many techniques for self update through spending money on hardware and software tools. Table show that how Indian banks spend money and where?

	<i>IT spend/ banking FTE</i>	<i>IT spend/ 1000 a/c's</i>	<i>Network spend/access point</i>	<i>Desktop+ helpdes spend/desktop</i>
<i>Best Indian Banks</i>	2.4	10.2	7.0	0.4
<i>India</i>	6.2	15.9	11.9	0.5
<i>Sample Average</i>	9.1	n/a	11.7	1.0
<i>European Bank Average</i>	21.2	76	n/a	1.5

US\$000s; 2007

*Source:* Mckinsey & company Proprietary IT benching making survey of leading banks in India: Mckinsey Analysis

### CONCLUSION

Computers and communication technology has not only increased the competition among the financial institutions in general and the banks in particular but have also opened new vistas for them to innovate and come up with newer products and services for the customers. Information technology has a direct impact on vital aspects of banks, all the major components of a banks, viz its organizational structure ,the customers, personnel and data evolve under the impact of the technology and react to the changes. IT has stiffed the competition and the banks have come out with newer products and service delivery systems .Training and restraining of staff have become critical factors for banks for successful utilization of IT.

**REFERENCES**

- [1] Johari and Jauhari(1994) Role of computers in banking Operation System, Himalaya Pub. House, New Delhi
- [2] Kalakota, R.(2000)E-Business, Pearson Education, Asia  
<http://www.iibf.org.in>  
<http://www.rbi.co.in>
- [3] Avasthi, G.P.M(2000), Information Technology in Banking: Challenges for regulators, prajnam, Vol.XXIX, No.4
- [4] Bajaj, KK, (2000)Ecommerce Issues in the emerging Hi – Tech Banking Enviorment, The Journal of the Indian Institute of Banker, Jan-March
- [5] Audrey Gilmore, (1990), "Services marketing and Management", TMH
- [6] D. Ghosh Roy (Dec2002), "Service Quality Management in Banks". BDP Publishers
- [7] B.R.Parthasarathi (Nov.2005), "Customer Service in Banks and its importance", Excel publisher
- [8] Shyam Ji Mehrotra (April 2006), Bank Marketing, Phb publisher
- [9] [www.nabard.org](http://www.nabard.org)
- [10] [www.financialexpress.com](http://www.financialexpress.com)

# Impact of Goods and Service Tax on Oil and Natural Gas Industry – A Case Study of Indian Oil Corporations Ltd.

SONAL GUPTA<sup>1</sup> AND AKSHIT GUPTA<sup>2</sup>

## ABSTRACT

*The issue of Goods and Services Tax (GST) is paramount for every organization these days. GST is a proposed system of “Single Tax” that replaces all indirect taxes levied on goods and services by the central and state governments. It is destination based tax which is to be levied and collected at each stage of sale and purchase of goods and services with credit of taxes paid at previous stages available as setoff. Indian Oil Corporation Ltd. (IOCL) is India’s largest commercial enterprise, with a sales turnover of Rs.3,99,601 crore (US\$ 61 billion) and profits of Rs.10,399 crore (US\$ 1,589 million) for the year 2015-16. The present study aims to understand the impact of GST on Indian Oil Corporations Ltd., and estimate the amount of losses/gains IOCL may suffer. Descriptive Research was carried out for the present study. The data was collected by an in-depth study of the published financial statements including balance sheet and profit and loss statement for a period of two years from FY 2014-16 of the company and the model GST law was referred. Discussions were also carried out with the seniors of the company. The study concludes that 5 petroleum products (Crude oil, natural gas, aviation fuel, diesel and petrol) are excluded from the coverage of GST for the initial years, while the rest are covered by GST (naphtha, bitumen, kerosene etc.) The prime problems that would be faced by the company includes registration in multiple states along with difficulties in claiming credits against the taxes paid on input services. GST will lead to massive changes in the existing structure of the company and may lead to losses to some of the divisions of the business entity.*

*The present study recommends proper indemnity for ensuring suitable collection for getting credit of GST should be done and the SAP masters should be updated with HSN and SAC codes which will be mandatory under GST regime.*

**Keywords:** Goods and Service Tax, Indirect Taxes, Model GST Law, Petroleum Products

## INTRODUCTION

Tax policies forms the backbone of every economy through their impact on both efficiency and equity. A good tax system should keep in view issues of income distribution and, at the same time, also endeavour to generate tax revenues to support government expenditure

---

<sup>1</sup> Assistant Professor, Hansraj College, University of Delhi  
E-mail: sonal775@Gmail.Com

<sup>2</sup> Student, B.Com(Hons), Hansraj College, University of Delhi  
E-mail: akshit41@gmail.com



on public services and infrastructure development. Goods and Services Tax (GST) is a proposed system of “Single Tax” that replaces almost all indirect taxes levied on goods and services by the central and state governments in India. Once implemented, the GST will subsume various taxes including excise, services tax, VAT, central sales tax, octroi and other levies and the proceeds will be shared between the Centre and states. It is destination based tax which is to be levied and collected at each stage of sale and purchase of goods and services with credit of taxes paid at previous stages available as setoff. Instead of goods being taxed multiple times at different rates, under the new GST regime goods would be taxed at point of consumption. In a nutshell, only value addition will be taxed and burden of tax is to be borne by the final consumer. GST is dual system where Central GST (CGST) and State GST (SGST) can be levied on taxable value of a transaction. A four-tier GST tax structure of 5%, 12%, 18% and 28%, with lower rates for essential items and the highest for luxury and de-merits goods that would also attract an additional cess, was decided by the GST Council. The main objective of GST is to develop a harmonized national market of goods and services.

Indian Oil Corporation is India’s largest commercial enterprise, with a sales turnover of **Rs.3,99,601 crore (US\$61 billion)** and **profits of Rs.10,399 crore (US\$ 1,589 million) for the year 2015-16**. Indian Oil is ranked **161<sup>st</sup>** among the world’s largest corporates in the prestigious Fortune ‘Global 500’ listing for the year 2016. Indian Oil has been meeting India’s energy demands for over half a century. With a corporate vision to be ‘**The Energy of India**’ and to become ‘A globally admired company,’ Indian Oil’s business interests straddle the entire hydrocarbon value-chain – from refining, pipeline transportation and marketing of petroleum products to exploration & production of crude oil & gas, marketing of natural gas and petrochemicals, besides forays into alternative energy and globalization of downstream operations. It is controlling India’s 11 out of 23 refineries with a group refining capacity of 80.7 MMTPA and a cross country network of crude oil, product and gas pipelines arching over 11,750km with a capacity of 85.5 MMTPA.

A major diversified, transnational, integrated energy company, with national leadership and a strong environment conscience, playing a national role in oil security & public distribution. Indian Oil nurtures the core value of care, innovation, passion and trust across the organization to deliver value to its stakeholders.

## **VISION OF THE COMPANY**

The oil and gas industry can be broken down into three key areas: **Upstream, Midstream, Downstream**

- Upstream component is also referred to as the E&P. This involves search for underwater and underground **natural gas** fields or crude oil fields and the drilling of exploration wells and drilling into established wells to recover oil and gas. Oil and Natural Gas Corporation (ONGC) is the leading player in this sector, operating with close to 75% of the market share in terms of crude oil output.
- Downstream refers to the filtering of the raw materials obtained during the upstream phase. This means refining crude oil and purifying natural gas. The marketing and commercial distribution of these products to consumers and end users in many forms

including: natural gas, diesel oil, petrol, gasoline, lubricants, kerosene, jet fuel, asphalt, heating oil, LPG (liquefied petroleum gas) as well as many other types of petrochemicals. IOCL is again a market leader in this segment, operating 11 out of 22 refineries across India. IOCL being a state-owned enterprise faces its closest competition from Reliance Industries limited

- **Midstream** is generally classified under the downstream category.

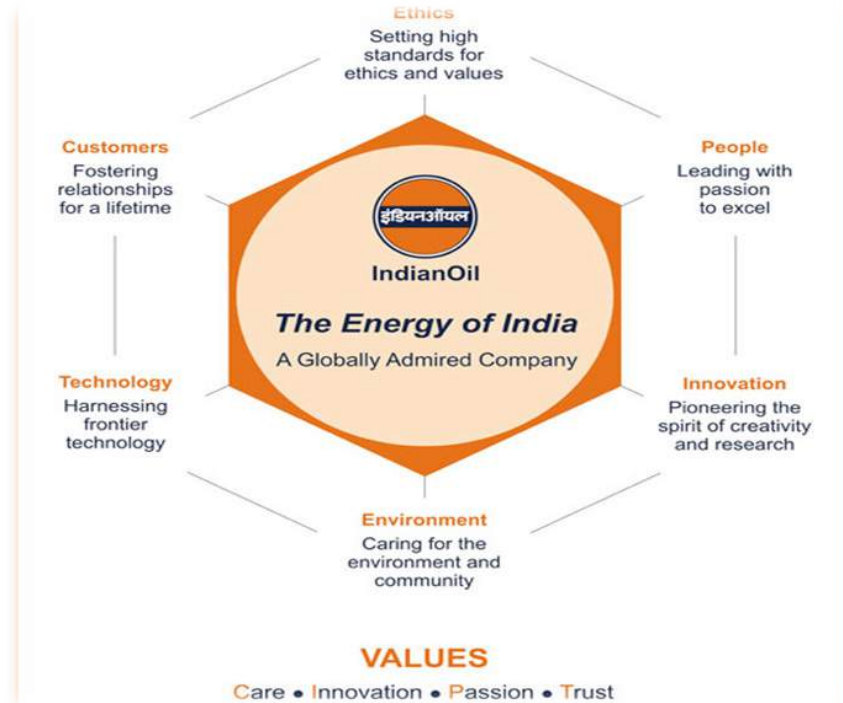

Figure 1: Source-<https://www.iocl.com/NewImages/Misc/VisionWebsite.jpg>

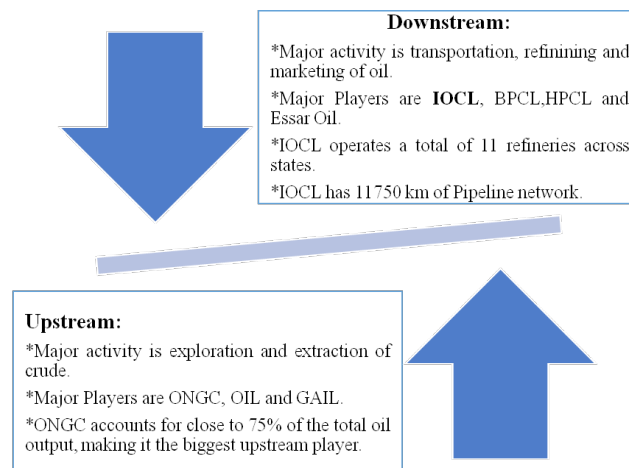

Figure 2

## BACKGROUND

Indian Indirect Tax system has been reformed several times since its evolution. Having emphasis on better government revenue collection, India has introduced various taxes on goods and services such as MOD-VAT, CENVAT, Service tax and Sales tax being replaced by VAT etc.

The concept of GST is also not new to India. It had its origin in 2000 when an empowered committee was set up by the Atal Bihari Vajpayee administration headed by Mr. Asim Dasgupta (Finance Minister, Government of West Bengal) to streamline the GST model to be adopted and to develop the required back-end infrastructure that would be needed for its implementation. This law was in pipeline for implementation since 2006 when it was introduced in Parliament by then Finance Minister Shri P. Chidambaram. In his budget speech on 28 February 2006, he announced the target date for implementation of GST to be 1 April 2010 and task of designing GST was given to empowered committee of State Finance Ministers. The 115<sup>th</sup> Constitution Amendment Bill was introduced in March, 2011 in Lok Sabha. The Bill lapsed due to dissolution of Lok Sabha. After great amount of deliberations, Constitution 122<sup>nd</sup> Amendment Bill, 2014 was introduced on 19<sup>th</sup> December 2014 by Union Finance Minister Mr. Arun Jaitley. *The Lok Sabha passed the bill on 6<sup>th</sup> May 2015 and the same was passed by Rajya Sabha on 3<sup>rd</sup> August 2016.* The GST is administered & governed by GST Council and its Chairman is Union Finance Minister of India Arun Jaitley. The Goods & Services Tax Council (GST Council) was created in September 2016 under Article 279-A of the Constitution of India. It has its Secretariat office in New Delhi, consisted of The Union Finance Minister (as Chairman), The Union Minister of State in charge of Revenue or Finance, and The Minister in charge of Finance or Taxation or any other Minister, nominated by each state government. The decisions of the GST Council are made by three-fourth majority of the votes cast. The centre has one-third of the votes cast, and the states together have two-third of the votes cast. Each state has one vote, irrespective of its size or population.

*The first ever implementation of GST dates back to 1954 when France became the first country in the world to bring it into action.* Presently, there are around 160 countries that have implemented GST/VAT in some form or other. In some countries, VAT is the substitute for GST, but conceptually it is a destination based tax levied on consumption of goods and services.

## SIGNIFICANCE OF THE STUDY

GST is a crucial step taken by Government of India that is why it becomes the very need of the present study to check the positive and negative effects of the reform on the Indian economy. Many researchers, academicians and analysts have given their views on the impact of this reform on the economy of a country. Thus, this study is important to analyse the effect GST has on a particular sector of the economy and how individual sector carries varied impacts in respect of GST. The present study aims to understand the impact that GST will have on Indian Oil Corporations Limited.

## OBJECTIVE OF THE STUDY

The objective of the present study can be listed out as:

1. To check the impact of GST on the working of IOCL.
2. To estimate the profit/losses that IOCL division will suffer due to GST.

## RESEARCH METHODOLOGY

This study is based upon descriptive research. The primary data was collected by discussions with the seniors of the company. The secondary data was collected by an in-depth study of the published financial statements including balance sheet and profit and loss statement for a period of two years from FY 2014-16 of the company, the model GST law and divisional financial accounts were also referred.

## FINDINGS OF THE STUDY

After analysing all the reports and carrying out discussions with the seniors the findings of the study can be classified under two heads namely, the impact of GST on the entire company and the same on a particular division i.e. Pipeline Division.

## IMPACT ON IOCL

- Five oil and natural gas products namely, motor spirit, high speed diesel, aviation turbine fuel, natural gas and crude oil are kept outside the GST regime which accounts for around 75% of the total business of the company.

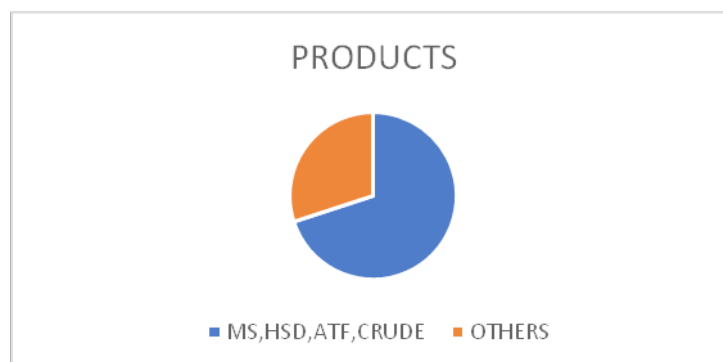

<i>Particulars</i>	<i>Present Regime</i>	<i>Gst Regime</i>
Registration	In the current Service Tax law, single centralised registration may be taken by the entity.	In GST regime, entities will be required to take single registration for each state. (or may opt for Vertical based registration in case they think that tax credit availability in that scenario is favourable for a concern.)

<i>Particulars</i>	<i>Present Regime</i>	<i>Gst Regime</i>
Matching Concept	Presently, no concept of matching the entry is followed in any of the indirect taxes. The input tax paid at the time of procuring a service can be offset against the tax liability on output services under CENVAT CREDIT RULES,2004.	Under GST regime the credit of GST can only be availed once it has been paid to the supplier and is reflected in the account of the recipient when the supplier files his return.
Subsidies	-----	As per the MGL (november'16) the transaction value of a good will include the subsidies that are related to the price but not the subsidies that are given by Central or State govt.
Cascading Effect	The present regime carries the biggest drawback of cascading which simply means tax on tax. For example, when a good is manufactured and there is an	In GST regime, the cascading effect of tax will be removed and the tax will only be charged on the value that has been added to the good and not the sale price.
	inter-state supply then CST is applied on an amount already inclusive of Excise duty.	
Anti-Profiteering Measures	No measures exist in the current regime.	They have been introduced under the Model GST Law wherein the extra profits that a company earns due to easy availability of credits needs to be transferred to the final consumers.
Penalty On Late Payments	Presently, no such rule exists in any of the indirect taxes.	Section 15 of the Model GST Law states that the penalty or fees charged on late payments shall also levy GST.
Working Capital	—	The working capital requirements of the company are going to increase in GST regime due to an additional liability of paying taxes on pipeline division along with delays in credit availment.

- According to the Model GST Law the time of supply of goods under reverse charge mechanism is by the earliest of the following:
  - (1) Date of receipt of goods
  - (2) Date of payment made
  - (3) Date immediately following 30 days from the date of invoice
  - (4) If the above cases donot apply,then the date of entry in the books of recipient of supply will be considered.

So, as per the provisions reverse charge is to be paid in cases where goods are not received but 30 days from date of invoice have lapsed.

### IMPACT ON PIPELINE DIVISION

- The present tariff mechanism of pipeline division is:  
Cost of Transaction (COT) is calculated quarterly based on the quantity delivered as per the signed reconciliation statements.  
 $COT = \text{Quantity Delivered} \times 75\% \text{ of Notional Rail Freight (NRF)}$   
Presently no tax is charged on Freight recovery (Cost of Transportation) by Pipelines Division on other Divisions as Pipelines Division is only transporting Crude/Products to other Divisions of IOCL. If we go strictly as per law Schedule 1 Clause 5, Supply of goods and / or services by a taxable person to another taxable or non-taxable person in the course or furtherance of business will be treated as supply even if there is no consideration
- The current process of availing input tax credit involves consolidation of all the credits across the company by the ISD and then distribution of that credit to the respective refineries which set them off against the excise duty to be paid. But under the GST regime, the credit of CGST and SGST cannot be set against each other whereas the credit of IGST can be set off against both CGST as well as SGST. So in the upcoming months different ledgers needs to be maintained to segregate the credits and use them appropriately. Also, tax credit presently not available may be available in future.

<i>Type of Tax</i>	<i>Reason For Non-Availing Tax Credit Presently</i>	<i>Justification For Availability or Non-Availability Under GST Regime</i>
ITC on VAT (VAT on Inputs/ Capital goods)	Manufacturer will be entitled to take credit of tax paid on Inputs/ Capital Goods used by him in manufacture, purchased within the state. Credit will be available only in respect of inputs/ capital goods used in manufacture or processing. Inputs/ capital Goods used in Crude Pipelines should be considered as to be used in manufacturing activity.	Under GST regime, we may get the credit on the said transaction.

<i>Type of Tax</i>	<i>Reason For Non-Availing Tax Credit Presently</i>	<i>Justification For Availability or Non-Availability Under GST Regime</i>
Excise Duty & CVD Credit on Pipelines used outside the factory for the manufacture of final products	The above goods are considered as capital goods when they are used: in the factory for the manufacture of the final products outside the factory of the final products for generation of electricity for captive use within the factory. for providing output service.	The definition of capital goods has undergone a substantial change in the revised Model GST Law- Nov 2016. The definition of capital goods under revised GST Law is given under section 2(19) which states that: capital goods means goods, the value of which is capitalised in the books of accounts of the person claiming the creditand 2. which are used or intended to be used in the course or furtherance of business. Referring to the above definition, it seems that Pipelines Division can take the credit of Excise Duty on Capital Goods (i.e. Pipelines) irrespective of the condition of goods to be used in the factory for the manufacture of the final products.

## CONCLUSION

Tax policies play an important role on the economy of a country through their impact on growth and efficiency. A good tax system should meet five basic conditions: fairness, adequacy, simplicity, transparency, and administrative ease. Cascading effect of taxes have differential impacts on firms in the economy with relatively high burden on those not getting full offsets. This results in loss of income. There has been a good deal of criticism as well as appraisal of the proposed Goods and Services Tax regime. GST is not simply VAT plus service tax, but a major improvement over the previous system of VAT and disjointed services tax. A single rate would help maintain simplicity and transparency by treating all goods and services as equal without giving special treatment to some 'special' goods and/or services. Currently, there are differential rates of VAT for the same goods in different States with further fragmentism of VAT rates and this has resulted in classification disputes in the past. However, GST rates at both the Central and State level are expected to be uniform and harmonised which would reduce disputes.

The GST model will therefore facilitate seamless credit across supply chains, with tax set offs available across the production value-chain, both for goods and services. This will result in reduction of cascading effect of taxes, therefore bringing down the overall cost of supplies. It is hoped that this cost benefit would be ultimately passed on to the customers or help in increasing the books of the companies.

The actual impact of GST cannot be computed but as per the estimates, GST will lead to modest decline in profits of the company for a period of few years till the petroleum products are taken inside the GST regime. Thus, this will increase the burden of the company by ensuring compliance with two different tax regimes. But from July,2017 the actual GST law will be implemented and the actual impact will be seen which may give better results than expected.

## **SUGGESTIONS**

Although with the implementation of GST the profits of the the oil and natural gas industry will be modestly affected but these can be avoided to some extent by ensuring the following measures:

1. The IOCL can come up to some compromises with the existing/ future tenders wherein some of the tenders that are to be processed within the period of march'17 to june'17 can be put on hold till july'17 as the credit taken against this tenders within these months won't be shown in the returns and thus won't be claimable. These tenders must not be delayed at the cost of any ongoing projects.
2. Once the GST is rolled out the company can amend the terms and conditions of their tenders and can hold a certain amount of money as security deposits while making a payment to the supplier. The balance amount can be paid once the supplier has filed his/her returns and the credit for the same is added to the account of the company making the credit available to IOCL.
3. Under the current laws, definition & credit admissibility of capital goods is very restricted. However, under the Model GST Law (MGL), definition & credit admissibility of capital goods is liberalised i.e. any asset capitalized in books of accounts for furtherance of business is admissible. Thus, in case of inputs and capital goods where presently credit is not admissible but will be admissible in GST scenario, procurement of such items wherever possible should be deferred after the appointed day so that potential losses of credit under current law can be avoided.

## **SCOPE OF FURTHER STUDY**

The study has been conducted considering the Model GST Law introduced by the Government of India in November 2016. Moreover, the study has broadly focused on estimates because the true figures cannot be calculated before the implementation of GST Law. Thus, the present study is limited to few aspects. The same can be conducted in a more comprehensive way once the law is implemented and other sectors of the economy can also be focused upon including automobiles, information technology etc. Other companies of the oil and natural gas industry can be researched upon to have a better insight of the actual impact on this particular sector.

## **REFERENCES**

- [1] <http://iocl.com/>
- [2] <https://www.iocl.com/AboutUs/AnnualReports/AnnualReport201516.pdf>
- [3] <http://www.gstindia.com/history-of-gst/>
- [4] <http://www.gktoday.in/blog/composition-functions-of-gst-council/>
- [5] <https://gst.caknowledge.in/historical-background-gst/>
- [6] <http://www.ey.com/in/en/services/ey-goods-and-services-tax-gst>



- [7] <https://www.reference.com/business-finance/characteristics-good-tax-system-eee2570a94f212df>
- [8] <http://www.mondaq.com/india/x/508476/sales+taxes+VAT+GST/GST+Impact+Ecommerce+Sector>
- [9] <http://timesofindia.indiatimes.com/business/india-business/Final-GST-rates-out-slabs-fixed-at-5-12-18-28/articleshow/55225847.cms>
- [10] [http://economictimes.indiatimes.com/articleshow/53546933.cms?utm\\_source=contentofinterest&utm\\_medium=text&utm\\_campaign=cppst](http://economictimes.indiatimes.com/articleshow/53546933.cms?utm_source=contentofinterest&utm_medium=text&utm_campaign=cppst)
- [11] Indian Oil Pipeline Division, Performance Highlights 2015-16.
- [12] Corporate Presentations

# The Impact, Outreach and Sustainability of Microfinance Institution in Developing Nations

PALLAVI PANDEY<sup>1</sup>

## Abstract

*This paper investigates the empirical contributions with respect to a number of related and relevant issues on the economics of microfinance. The paper answers two main questions: (1) Does microfinance have an impact on the social and economic situation of the poor in Developing nations; and (2) Microfinance institutions sustainable in the long term and is there a trade-off between sustainability and outreach*

## INTRODUCTION

The inability of formal credit channels to deal with the credit requirement of poor led to the emergence of microfinance as an alternative credit system for poor. It refers to the small credit extended to poor people for self employment projects generating income allowing them to take care for themselves and their families. The microfinance has attracted attention, both from policy makers and academicians. The Economic Journal (Hermes & Lensink, 2007) has pointed that many questions regarding microfinance are still unanswered. The question in particular that received more attention: (1) does microfinance have an impact on the social and economic situation of the poor in developing nations like India? The question holds importance as lot of efforts are taken by various financial institution to meet the financial demands of poor and develop microfinance institution by providing various supports (2) Are microfinance institutions sustainable in the long run this question again hold importance as to know can microfinance institution sustain themselves without compromising with their objectives.

The paper contains eight original contributions that provide new empirical evidence on these two issues. Four contributions answers the question of the impact of microfinance on the well-being of the poor in developing nations like India. Does impact of MFI's on social and economic situation of the poor in developing nations like India was significant? The latter four contributions focus on the trade-off between outreach and financially sustainable.

In the 2007 special issue in Economic Journal (Hermes & Lensink, 2007) elaborates on number of ways in which we primarily dealt with joint liability group lending, providing new insights with respect to why and how this type of lending works in enhancing repayment rates. The issue of the trade-off between the financial sustainability and outreach of microfinance programs were looked into and various forms of lending were considered

---

<sup>1</sup> Research Scholar, Bundelkhand University Jhansi

## **THE IMPACT OF MICROFINANCE**

The supporters of microfinance says that a proper access to finance can reduce poverty substantially (Dunford, 2006; Little field, Morduch, & Hashemi, 2003). Access to finance leads to increase in income by increasing investments in income generating activities and diversify sources of income; which may contribute to an accumulation of assets; smoothen consumption; likely to reduce the vulnerability due to illness, drought and crop failures, and it may contribute to social development and better standard of living of the borrower. The positive assessment of the contribution microfinance can reduce poverty led many governments, NGOs, and individuals to put efforts to support MFIs and their activities. Still, microfinance has faced many criticism. the critics of microfinance doubt substantial contribution in reduction of poverty and claimed that microfinance does not reach the poorest of the poor (Scully, 2004), or that the poorest are deliberately excluded from microfinance programs (Simanowitz, 2002). Reasons behind was the very poor often decided not to be a part of microfinance programs as they lack confidence in the products of institution or considered loans taking to be very risky (Ciravegna, 2005) the target segment of MFI'S (core poor) are very risk averse to borrow for investment in future the loan that was extended to people were very limited. Secondly the core poor borrowers are not considered by other lending programs because of the very high credit risk involved (Hulme & Mosley, 1996; Marr, 2004). Te way the programs are organized by MFI's lead to exclusion of core poor and even staff o MFI's prefer excluding as they are been considered very risky (Hulme & Mosley, 1996; Marr, 2004). Many microfinance scheme have a clear focus on women as they are bread winners of families. Research shows that women are more reliable and have higher pay-back ratios. Moreover, women use a more substantial part of their income for health and education of their children (Pitt & Khandker, 1998). Thus, women play a very important role in reducing poverty within households.

Due to large disagreement about the contribution microfinance to reduce poverty impact of microfinance led t0 a large number of empirical assessments. In this respect, researches have tried to answer following questions (1) does microfinance reach the core of the poor or it is for rich (2) which contribution is seen as the most important (improvement of income, accumulation of assets, empowerment of women, etc.); and (3) do the benefits outweigh the costs of microfinance schemes? (Chemin, 2008; Dunford,2006). The latter issue deals with the question to what extent subsidies to microfinance organizations are justified. Most studies aiming at evaluating the impact of microfinance by addressing above three questions

Even though several assessments of the impact of microfinance on poverty reduction have been made, there are very less empirical evidence on this issue. As there is no measure to estimate the contribution of MFI's to the poverty reduction. Some studies measured impact by comparing recipients of microfinance with a control group that has no access to microfinance. In most cases, these studies apply non-randomized approaches. These approaches firstly analyses the changes of the social and/or economic situation of the recipients of microfinance by induce rich agents to apply for microfinance whereas poor agents do not apply, Resulting in a self-selection bias. Such situation, may lead to the incorrect conclusion that microfinance has stimulated income. Second, in order to improve

the probability of microfinance being successful, MFIs may decide to develop their activities in relatively more wealthy regions

One of the influential studies in this field is by (Pitt and Khandker(1998)) on the impact of microfinance in Bangladesh, using household survey data for 1991–92. They find that access to microfinance has resulted in increased consumption expenditure, if loans are taken by women. Khandker (2005), in his latter study using panel data for 1991–92 and 1999, concludes that the extremely poor benefit more from microfinance than the moderately poor.

Based on data from a survey carried out in collaboration with a village banking program, Promuc, in Peru in 2002, and using a mix of evaluation methods (among which are the difference-in-difference approach and qualitative in-depth interviews) they found that it is the “better off” poor benefit most from access to microfinance than the core poor or whom the programs was designed. The drawbacks of non randomized approaches have been overcome by the randomized approach but the evidences using the randomized approach appeared to be mixed Coleman (1999, 2006) is one of the first to use a randomized approach when evaluating the impact of microfinance, he used an external event, that is, a microcredit program introducing microfinance in the Northeastern part of Thailand with random and unannounced delays. Based upon this quasi-experimental setting his analysis shows that microfinance has a positive impact on wealthy villagers only. Karlan and Zinman (2009) study the effect of microcredit on small business investment in Manila, the Philippines. The picture emerging from their results is rather diffuse. Banerjee, Duflo, Glennerster, and Kinnan (2009) evaluate the impact of the opening of MFI branches in the slums of Hyderabad. Half of the 104 slums were randomly selected for new branches. They find mixed results, but on the whole the effect of introducing microfinance appears to be very moderate. But still randomized controlled trials were criticized (Deaton, 2009; Rodrik, 2008). As the result of the experiment cannot be generalized, the solution to the problem, as argued by the proponents of randomized approaches, is to repeat experiments in different contexts, it remained unclear how many times a particular experiment should be repeated before concluding. Repeating experiments is very costly and time consuming therefore result concluded both randomized and non-randomized approaches have weaknesses and strengths, and, therefore, both could be useful when analyzing the impact of microfinance.

The brief discussion above on the evidence of the impact of microfinance on poverty shows that no proper conclusion is drawn as there is no proper tool to measure the impact. The contributions in this paper aim to provide in-depth and innovative analyses of microfinance and their impact on poverty reduction. Below, we will shortly review the contents of these contributions. The first contribution is same as non-randomized approaches; the second and third contributions are close to randomized approaches to analyze the impact of microfinance; and the fourth contribution proposes an alternative methodology for impact assessment.

The paper by Dalla Pellegrina (2011) paper aims at analyzing the impact of microfinance by comparing impact of two other sources of credit, that is, bank loans and informal credit. Such a comparison is, however, important as it helps our understanding about the real contribution microfinance can make. Secondly, her study focuses on the impact of

credit on investment, Dalla Pellgrina stresses that for improving living standards in the long term, investments are needed so that borrowers can develop productive activities. Using information from a large survey on almost 1,800 households in rural Bangladesh carried out by the World Bank in 1991–92, she finds that microfinance loans mainly help to increase working capital expenditure, whereas bank loans play an important role in accumulating fixed assets. The latter are most important to generate long-term productive activities. These results indicate that with respect to the impact on long-term investments, microfinance may be less effective than bank loans.

Becchetti and Castriota (2011) analyzes the impact of microfinance by focusing on its effectiveness as a recovery tool after hit by the tsunami in Sri Lanka in 2004. They have data for 305 randomly selected microfinance borrowers, disaster provided a unique quasi-natural experiment to test the impact of microfinance on people's well-being, because it creates two randomly selected groups. One group of borrowers consists of those who are hit by the tsunami; the other group consists of borrowers who are not affected by the disaster. Based on a rich dataset containing information for both before and after the tsunami which showed the positive contribution of microfinance loans led to improving and converging real incomes was not observed for governmental subsidies, donations, and grants. Their study thus finds strong evidence for the effectiveness of microfinance as a recovery tool.

Rai and Ravi (2011) in their paper focus on the impact of microfinance on women empowerment. They study uses dataset of 280,000 microfinance borrowers in India, the borrowers were asked to purchase health insurance after getting loan. However it aims to empower women and these partnerships may contribute to this aim, since usually women are less likely to seek and obtain health insurance.

## **MICROFINANCE: SUSTAINABILITY VERSUS OUTREACH?**

Providing microfinance is a costly business due to high transaction and information costs. At present, a large number of microfinance programs are still dependent on donor subsidies to meet the high costs, which made them financially unstable. The financial systems approach emphasizes the importance of financially sustainable microfinance programs approach stressed on the importance of being able to cover the cost of lending money out of the income generated from loan portfolio, reduce operational costs. The poverty lending approach, focussed on use of credit to overcome poverty, by providing credit on low interest rates as the poor cannot afford higher interest rates. Therefore financial sustainability is in conflict with goal of serving large groups of poor borrowers. In other words, there is a trade-off between sustainability and outreach. But the large-scale outreach to the poor on a long-term basis cannot be guaranteed if MFIs are not financially sustainable. In fact, the importance of striving for financial sustainability has been embraced by most parties in the microfinance debate as a result donors, policy makers, and other financiers of microfinance have recently made a shift from subsidizing MFIs institutions toward a focus on financial sustainability and efficiency of these institutions. Thus increased focus on financial sustainability and efficiency is due to a number of changes the microfinance business has been recently witnessed, increasing competition among MFI's, commercialization

of microfinance, technological advancement and financial liberalization and regulation policies of the government (Rhyne & Otero, 2006).

Cull, Demirgüç-Kunt, and Morduch (2007) his study aims to systematically examine financial performance and outreach in a large comparative study based on a dataset of 124 microfinance institutions in 49 countries, investigate whether there is a trade-off between the depth of outreach and profitability of MFIs. The results show individual-based MFIs increasingly focus on wealthier clients, provides evidence for a trade-off between sustainability and outreach and stresses the importance of institutional design in determining the existence and size of such a trade-off. Hermes, Lensink, and Meesters (2011) provide new evidence on the existence of the trade-off between sustainability and outreach, using data for 435 MFI for the period 1997–2007. Finds strong evidence that outreach is negatively related to efficiency of MFIs. MFIs with a lower average loan balances are less efficient. Moreover, MFIs with more women borrowers as clients are also less efficient. The results are significant even after taking into account a long list of control variables.

Hudon and Traca (2011) in their paper focus on the relationship between subsidies and the efficiency of MFIs. According to their report, only 5% of all MFIs are currently operationally sustainable. As providers of subsidy require transparency related to the effects of their subsidies on the performance of MFIs, the subsidies have kept inefficient institutions alive. Hudon and Traca use microfinance ratings data from two leading rating agencies, providing them with financial statement data for 100 MFIs. Using this unique dataset they find evidence for a positive relationship between the subsidy intensity and the efficiency of MFIs. subsidizing MFIs may contribute positively to efficiency, but only up to a certain maximum level. Wydick, Karp, and Hilliker (2011), investigates determinants of outreach, uses an innovative approach by looking into the role played by social networks in determining access to microfinance loans. Recently, there has been a new wave of research emphasizing the role of social networks on individual decision making.

## **LESSONS TO BE LEARNED?**

After reviewing the contents of the various contributions to this paper on microfinance, the question remains what new insights these contributions have provided regarding the impact of microfinance and the trade-off between outreach and sustainability

### **(a) Impact**

Dalla Pellegrina (2011) supports the view that, for MFIs, it is important to understand the potential impact of the lending technology and contract on the behavior and choices made of the borrower on deciding the ultimate aim should be of providing loans to the poor. One potential response that accommodates this insight may be to reconsider lending technologies used and turn to approaches in which the lending technology allows for more flexibility than is usually the case. That there is convincing evidence for a positive impact of microfinance, at least in the two cases discussed in the work of Becchetti and Castriota (2011) and Rai and Ravi (2011). So, microfinance does seem to make a difference in

recovery after a natural disaster and it does seem to help empowering women. These results are reassuring as both areas are high on the agenda of many NGOs and policy makers.

In many cases, these methodologies are very costly and time consuming. It generally takes several rounds of surveys over a relatively long period of time before adequate data have been collected. The contribution by McIntosh et al. (2011), the methodology they suggest allows for creating a retrospective panel database based upon a single survey, using the client base of the MFI(s) involved in the analysis. The simple idea is to ask respondents to think about major changes in the household in the past and link these changes to the timing of a treatment such as having access to a micro-finance loan. This methodology allows for explicitly analyzing the dynamics of the impact of a treatment. This methodological innovation may, therefore, be very useful for both researchers and policy makers when evaluating the impact of microfinance.

### **(b) Outreach versus sustainability**

The contributions on the outreach versus sustainability discussion has threefold. Aiming for sustainability does compromise the social goals of MFIs (Hermes et al., 2011). Transformation of MFI's to banks have positive impact on socially deprived. It is of great importance to policy makers deciding on whether or not to subsidize microfinance, it is important for practitioners in their decisions to improve the efficiency of their operations further; and it is important for commercial investors, those aiming for socially responsible investments. There are no proper evidence to answer the question regarding the size of trade-off. One first attempt of analyzing this issue is made by Galema and Lensink (2009). Taking small sample of 25 MFIs, to estimate extent the social investors are willing to accept a decrease on returns to achieve higher outreach. The trade-off is particularly severe for the lower end of the poverty distribution, that is, the group that by MFIs. Obviously, more research into the size of the trade-off is needed in future to be able to come to convincing conclusions on this issue. Another, related lesson from the symposium contribution by Hudon and Traca (2011) is that subsidies if remain moderate do not have to compromise on the efficiency. In particular, providing well planned subsidies may improve the performance of MFIs. The view for financial sustainability only may not be a fruitful venue when discussing the long-term viability of microfinance work. The innovation provided by Wydick et al. (2011) focuses on the use of existing social networks between existing and potentially new microfinance clients. According to Wydick et al. MFIs could make more use of these networks when reaching out to the poor as it turns out that households may be willing to apply for microfinance because other households in the same network do so as well. Using these networks is a low-cost strategy for MFIs when reaching out to new clients. With respect to the discussion on the trade-off between outreach and sustainability this is an important conclusion, because this would better enable MFIs to reach higher levels of outreach without having to compromise its financial sustainability.

## **REFERENCES**

- [1] Banerjee, A., Duflo, E., Glennerster, R., & Kinnan, C. (2009). The miracle of microfinance? Evidence from a randomized evaluation. Unpublished paper, Abdul Latif Jameel Poverty Action Lab and MIT.

- [2] Becchetti, L., & Castriota, S. (2011). Post Tsunami intervention and the socioeconomic well-being of microfinance borrowers. *World Development*, 39(6), 898–912.
- [3] Berg, G., & Schrader, J. (2009). Can microcredit help to cope with aggregate shocks? Evidence from Ecuador. Paper presented at the first European research conference on microfinance, 2–4 June, Brussels.
- Chemin, M. (2008). The benefits and costs of microfinance: Evidence from Bangladesh. *Journal of Development Studies*, 44(4), 463–484.
- [4] Ciravegna, D. (2005). The role of microcredit in modern economy: The case of Italy. [www.flacso.or.cr/fileadmin/documentos/FLACSO/auCiravegna2.DOC](http://www.flacso.or.cr/fileadmin/documentos/FLACSO/auCiravegna2.DOC).
- Coleman, B. E. (1999). The impact of group lending in Northeast Thailand. *Journal of Development Economics*, 60(1), 105–141.
- [5] Coleman, B. E. (2006). Microfinance in Northeast Thailand: Who benefits much?. *World Development*, 34(9), 1612–1638.
- [6] Collins, D., Morduch, J., Rutherford, S., & Ruthven, O. (2009). *Portfolios of the poor: How the world's poor live on \$2 a day*. Princeton: Princeton University Press.
- [7] Copstake, J., Dawson, P., Fanning, J. P., McKay, A., & Wright-Revollo, K. (2005). Monitoring the diversity of the poverty outreach and impact of microfinance: A comparison of methods using data from  
[8] Peru. *Development Policy Review*, 23(6), 703–723.
- [9] Cull, R., Demirgüç-Kunt, A., & Morduch, J. (2007). Financial performance and outreach: A global analysis of lending microbanks. *The Economic Journal*, 117(1), F107–F133.
- [10] Cull, R., Demirgüç-Kunt, A., & Morduch, J. (2011). The effect of regulation on MFI profitability and outreach. *World Development*, 39(6), 949–965.
- [11] Dalla Pellegrina, L. (2011). Microfinance and investment: A comparison with bank and informal lending. *World Development*, 39(6), 882–897.
- [12] Deaton, A. (2009). Randomization in the tropics, and the research for the elusive keys to economic development. Unpublished paper, Center for Health and Wellbeing, Princeton University.
- [13] Deutsche Bank Research (2007). *Microfinance: An emerging investment opportunity*. Frankfurt am Main: Deutsche Bank.
- [14] Dunford, C. (2006). Evidence of microfinance's contribution to achieving the millennium development goals. *Freedom from Hunger*. [nancgateway.org/files/35795\\_file\\_Evidence\\_on\\_MDGs\\_Dunford.pdf](http://nancgateway.org/files/35795_file_Evidence_on_MDGs_Dunford.pdf).
- [15] Easterly, W. (2009). Development experiments: Ethical? feasible? useful? [http://blogs.nyu.edu/fas/dri/aidwatch/2009/07/development\\_experiments\\_ethica.html](http://blogs.nyu.edu/fas/dri/aidwatch/2009/07/development_experiments_ethica.html), July 16.
- [16] Galema, R., & Lensink, R. (2009). Social investment in microfinance: The trade-off between risk, return and outreach to the poor. Unpublished paper, Centre for International Banking, Insurance and Finance, University of Groningen, Groningen.
- [17] Goetz, A. M., & Gupta, R. S. (1996). Who takes the credit? Gender, power, and control over loan use in rural credit programs in Bangladesh. *World Development*, 24(1), 45–63.
- [18] Hartarska, V., & Nadolnyak, D. (2007). Do regulated microfinance institutions achieve better sustainability and outreach: Cross-country evidence. *Applied Economics*, 39, 1207–1222.
- [19] Hermes, N., Lensink, R., & Meesters, A. (2011). Outreach and efficiency of microfinance institutions. *World Development*, 39(6), 938–948.
- [20] Hermes, N., & Lensink, R. (2007). The empirics of microfinance: What do we know?. *The Economic Journal*, 117(1), F1–F10.
- [21] Hoque, S. (2008). Does micro-credit program in Bangladesh increase household's ability to deal with economic hardships? MPRA Paper No.6678, Department of Economics, Monash University, Australia



- [22] Hudon, M., & Traca, D. (2011). Subsidies and sustainability in microfinance. *World Development*, 39(6), 966–973.
- [23] Hulme, D., & Mosley, P. (1996). *Finance against poverty*. London:Routledge
- [24] Karlan, D. (2001). Microfinance impact assessments: The perils of using new members as a control group. *Journal of Microfinance*, 3(2), 75–85.
- [25] Karlan, D., & Zinman, J. (2009). Expanding microenterprise credit accessing randomized supply decisions to estimate the impacts in Manila.
- [26] Unpublished paper, Innovations for Poverty Action. Khandker, S. R. (2005). Microfinance and poverty: Evidence using panel data from Bangladesh. *The World Bank Economic Review*, 19(2), 263–286.
- [27] Khandker, S. R. (2007). Coping with flood: Role of institutions in Bangladesh. *Agricultural Economics*, 36, 169–180.
- [28] Kirkpatrick, C., & Maimbo, M. (2002). The implications of the evolving microfinance agenda for regulatory and supervisory policy. *Development Policy Review*, 20(3), 293–304.
- [29] Littlefield, E., Morduch, J., & Hashemi, S. (2003). Is microfinance affective strategy to reach the Millennium Development Goals? CGAP Focus Note 24, Washington DC: CGAP
- [30] Marr, A. (2004). A challenge to the orthodoxy concerning microfinance and poverty reduction. *Journal of Microfinance*, 5(2), 1–35.
- [31] McIntosh, C., Villaran, G., & Wydick, B. (2011). Microfinance and home improvement: Using retrospective panel data to measure program effects on discrete events. *World Development*, 39(6), 922–937.
- [32] Mosley, P. (2001). Microfinance and poverty in Bolivia. *Journal of Development Studies*, 37(4), 101–132.
- [33] Pitt, M. M., & Khandker, S. R. (1998). The impact of group-based credit programs on poor households in Bangladesh: Does the gender of participants matter?. *Journal of Political Economy*, 106(5), 958–996.
- [34] Rai, A., & Ravi, S. (2011). Do Spouses make claims? Female empowerment and microfinance. *World Development*, 39(6), 913–921.
- [35] Rhyne, E., & Otero, E. (2006). *Microfinance through the next decade: Visioning the who, what, where, when and how*. Paper commissioned by the Global Microcredit Summit 2006, Boston MA: ACCION International.
- [36] Robinson, M. (2001). *The microfinance revolution: Sustainable banking for the poor*. Washington, DC: The World Bank.
- [37] Rodrik, D. (2008). *The new development economics: We shall experiment, but how shall we learn?* Unpublished paper, John F. Kennedy School of Government, Harvard University.
- [38] Roodman, D., & Morduch, J. (2009). *The impact of microcredit on the poor in Bangladesh: Revisiting the evidence*. Working paper 174, Washington, DC: Center for Global Development.
- [39] Scully, N. (2004). *Microcredit: No panacea for poor women*. Washington, DC: Global Development Research Centre.
- [40] Simanowitz, S. (2002). *Microfinance for the poorest: A review of issues and ideas for contribution of Imp-Act*. ImpAct—Improving the impact of microfinance on Poverty: An Action Research Program
- [41] Westover, J. (2008). The record of microfinance: The effectiveness/ineffectiveness of microfinance programs as a means of alleviating poverty. *Electronic Journal of Sociology*, 12(1), January.
- [42] Wydick, B., Karp, H., & Hilliker, S. (2011). Social networks, neighborhood effects and credit access. *World Development*

# The Trend of Various Start-Ups to Domicile Overseas: An Overview of Current Scenario in Venture Capital Funding

DEEPAK BANSAL<sup>1</sup>

## Abstract

*Increase in inventive concepts and entrepreneurial spirit in the country will not only draw attention of domestic Venture Capital and individuals, but will also see enhanced interest of overseas investors. With 'Make In India' & 'Startup In India' campaigns, several state bodies are working towards creating a support system to boost the startups in their respective areas. While the growing technology penetration is a reason enough for an optimistic wave among investors for startups, the government's support would be an added advantage. However, the success of many startups will also depend on how they plan to spend. My advice would be to spend wisely, celebrate failures and learn from the mistakes you make while creating a business. No sustainable business is born overnight; so mistakes are inevitable. Pick up the best lessons out of these falls and move along.*

*The year ahead will see the coming-of-age of applications focused on making payments easier. Startups will have become nimbler and agile to cope with the demands for generating revenues in a sustainable fashion. Finally, startups will rise to focus on opportunities rising from government's drive to make in India etc.*

**Keywords:** *Inventive, Entrepreneurial, Startup, Technology, Penetration, Investors, Overseas*

## INTRODUCTION

A mass exodus of tech startups is expected this year as an increasing number of young ventures shifts overseas in search of investors and a better regulatory environment and facilities unless the government takes steps to reverse the trend. Excessive red tape in processes such as early-stage investing and mergers and acquisitions is forcing young, promising ventures in India to shift overseas, So far the Indian economy has witnessed phenomenal growth for the Indian technology startup ecosystem, driven by factors such as massive infused capital, acquisitions and consolidations, increasing Internet and smart phone penetration, and an ever growing domestic market. Although the market has suffered in recent times due to considerable backlash against certain startups for layoffs, India will continue to grow as a startup incubator. As the environment is highly emergent

---

<sup>1</sup> Associate Professor, Delhi Technical Campus, Greater Noida, U.P.

where everything changes in under a month, making predictions for a year is almost like crystal ball gazing. However, 2016 will certainly witness significant progress in digital payments. With liberalization of KYC norms in mutual fund investments and various initiatives by NPCI, we will also witness greater financial inclusion and easier investments and transactions for individuals across the country.

A software product industry think tank estimates that as many as 75% of new technology startup firms, ranging from data analytics, mobility and security to cloud that intend to raise seed or venture capital will be domiciled outside the country. Jalandhar-based customer support software maker Kayako shifted to the UK after finding it difficult to work in the Indian regulatory environment. London made natural sense for Kayako because of the UK's regulatory environment that includes friendly and pro-active tax regime and benefits such as R&D credits and capital gains tax credits for entrepreneurs.

Top Indian companies such as online retailer Flipkart and mobile advertising firm InMobi have re-domiciled to Singapore. Hungry for intellectual property, the government and investors in these countries are welcoming Indian tech companies with a red carpet. Mobikon is one of several start-ups which have moved headquarters from India to Singapore in recent months. Start-ups also benefit from the funding available through growing angel investor and venture capital networks in Singapore. Mobikon, for instance, raised \$2 million in a joint investment from SPRING Singapore and Jungle Ventures. SPRING is a government-operated fund that invests in start-ups along with local venture capital firms. Easier listing norms and the dream of a US listing are also major attractions for startup ventures.

Exact data on such ventures is not available, but the number of Indian companies with operations in the citystate jumped to 4,000 in 2012 from 1,100 in 2000, according to the Singapore Economic Development Board (SEDB). Industry executives say a Singapore presence is ideal for companies aspiring to go global as the city-state is an international business hub. The trend is most visible in start-ups offering digital marketing, social media and cloud-based services. Singapore acts like a media buying hub for various companies across Southeast Asian nations such as Malaysia, Indonesia, and the Philippines.

Start-ups are multiplying rapidly in India. There are just too many of them. Most of them are mismanaged and have flawed business plans. They stare at an uncertain future with investors reluctant to hop on board. Here are a few suggestions for entrepreneurs on how to make their start-ups. Making the right pitch The start-up pitch is crucial for an entrepreneur. The more you talk about technology in your business, the more attention you garner from investors. Your start-up pitch should be like a pyramid, full of key details at the beginning and then slowly narrowing down to the future of the product or service, highlighting how it is beneficial to the end user.

Like most good stories, there's more than meets the eye. One has to dig beneath the hype to appreciate the underlying dynamics of an evolving ecosystem and its future trajectory. India's digital consumption market has reached its inflection point. Over the last three years, Internet and smartphone usage has seen annualised growth of over 30 per cent and 50 per cent, respectively, resulting in roughly 250 million connected users with diverse needs like shopping, travel, bill payments and financial management.

Over a quarter of these users are already conducting online transactions. Two-thirds of them access the Internet through their mobile phones (vs only a fifth in the US), and are consequently more engaged. Taking cue, businesses are increasingly getting online as evidenced by the 3.5 million SMEs active on digital marketplaces. Switch back to here and now. With 3,100-plus registered startups and counting, India is witnessing its own tech tsunami, and is poised to become the second largest global startup hub by the end of the decade (today the US is at 45,000-plus). This is the dawn of a new age.

Attracting top tier talent has also had a knock-on effect on the quality of product design and execution. By 2018, India will boast the largest global developer talent pool of 5.2 million, many of them seasoned by local R&D operations of tech multinationals. A reverse migration of US-based tech professionals, enticed by the potential to solve large problems in favourable market conditions with attractive compensation packages, has brought critical experience. But that's where the Indian halo ends -- and questions begin. The Indian startup ecosystem is hardly diversified on almost any other count. Over 80 per cent of funds have gone to consumer Internet and e-commerce startups, and hardly any to B2B technology. Consequently, little success has been seen in enterprise startups. There are no domestic counterparts for the Clouderas, Palantirs and Slacks of the Valley. This can be attributed to many factors -- short-term bias in the local VC community; higher risk aversion of Indian businesses in trying new technologies; and challenges in using typical copycat innovation models for B2B products.

According to ISpirit, a software product industry advocacy group, nine of the top 30 Indian B2B companies have already re-domiciled themselves abroad. This brain drain is significant given enterprise startups are twice as likely to become billion dollar companies.

### **Start-ups to Domicile Overseas**

In 2015, it is projected that three of four new technology startups that focus on the global market and plan to raise seed or venture capital will be domiciled outside India, according to a survey by iSPIRT (Indian Software Product Industry Roundtable), a think tank. This is like the 18th century East India Company invasion. The enormous value that is being created in tech industry is leaving our shores. A Singapore-based investor even offered \$100 million ( Rs 632.7 crore) in funding and infrastructure costs for 10 years to InMobi on condition that it increases its decision sciences team from 25 to 200 in the island nation. The city-state offers multiple benefits to start-ups Corporate tax rate capped at 17% versus over 30% in India Strong branding as a global business centre Works as a hub to expand presence across Southeast Asia Government subsidizes about half the salary of tech staff if they are locals Easier to start, operate and close a business there Liberal stock listing norms, allows direct overseas listing.

The UK government was totally on the ball. We were approached in person by Directors of UK Trade and Investment and other high level officials directly approached Kayako, which has over 30,000 clients including US space agency NASA, Japanese gaming firm Sega and Europe's second-biggest carmaker Peugeot. The government also arranged for a Tier 1 Entrepreneur visa within a record time of 20 days. It has been an amazing experience by those entrepreneur, who had to face tax-related regulatory hurdles in India.

Experts such as TV Mohandas Pai, a top angel investor and chairman of Manipal Global Education Services, said startups are finding it difficult to do business in the country. Every sale is becoming a nightmare for startups in India because of the regulations. The Indian tech start-ups are shifting their headquarters to the United States and Singapore, as it is lot easier for start-ups to raise money and have options for acquisition by tech companies like Facebook, Google and Twitter.

The situation is worse at the early stage. Among technology companies that raised Series A investments last year, 54% have already moved out of India, according to iSPIRT. Among them is Bengaluru-based mobile technology startup Deck, which relocated to Singapore entirely due to the funds raised. The investor was more comfortable investing in a Singapore company rather than in an Indian one, which enables users to make smart PowerPoint presentations through their mobile devices.

Mobile point-of-sale provider Ezetap, which provides its technology to banks such as State Bank of India and HDFC, had to re-domicile to Singapore to raise funds as investors didn't want to go through the hassles in India. Despite moving to Singapore, most start-ups retain their development centres and a heavy operational presence in India. Experts caution that companies should evaluate the strategic move carefully.

### **Current Scenario of Overseas Funding**

The government has made no provision for its ambitious India Aspiration Fund, part of StartUp India initiative, for the next financial year and has reduced the allocation to Rs 100 crore from Rs 600 crore made earlier for the current fiscal. In order to provide support to startups through Fund of Fund operations, IAF, with a corpus of Rs 2,000 crore, was launched by Finance Minister Arun Jaitley in August 2015 to enhance the equity availability to MSMEs. LIC was also made partner and co-investor in the India Aspiration Fund managed by SIDBI.

As per the Budget 2017-18 documents, the government had made allocation of Rs 500 crore for 2015-16 when the fund was launched. In the following year, a provision of Rs 600 crore was made but reduced significantly to Rs 100 crore as per the revised estimate announced in the Budget 2017-18. The Budget, announced earlier this month, has not made any allocation under this head for the next fiscal. At the time of the launch of the Fund, Jaitley had said it is expected to catalyse tens of thousands of crores of equity investment in start-ups and MSMEs. Instead of or in addition to disbursing part of the allocated money to venture capital funds operating in India, government should think about cutting inefficiencies and bringing more clarity by way of forming an expert panel that disburses funds directly to startups.

In the budget presented in July, Finance Minister Arun Jaitley had proposed to set up a Rs 10,000-crore fund to act as a catalyst to attract private capital by way of equity and loans for startup companies in the small and medium sector. The issues are not limited to raising funds or the tax system, many tech startups find it difficult to exit.

Experts said about 95 per cent of start-up exits happen through mergers and acquisitions and only 5 per cent happen by going public

Bengaluru-based information security firm iViZ Security, which was acquired by US-based technology firm Cigital in October, lost a significant amount of time during the exit process due to non-availability of a particular financial instrument in India. They, however, welcomed the recent easing of listing norms by the Securities and Exchange Board of India to help start-ups raise money locally. Manu Rekhi, director at Inventus Capital Partners, told Mr. Jaitley: “A Facebook corporate development executive vented to me about the complexity of doing a deal in India. He mentioned that the \$22 billion acquisition of WhatsApp in the U.S. was simpler than the \$10 million acquisition of Little Eye Labs in India.”

Nine of the top 30 business-to-business software product companies by market capitalisation have already relocated to the U.S., Singapore and the U.K., according to iSpirt’s Software Product index (iSPIx), which tracks the growth of the industry. These 30 companies are worth about \$6.2 billion (Rs. 39,341 crore), employing about 18,000 people, according to the index. Top Indian companies such as online retailer Flipkart and mobile advertising firm InMobi have re-domiciled to Singapore. (Source: Business Today, 2016)

Naushad Forbes, president of Confederation of Indian Industry, mentioned that the China growth story was fuelled by about 50,000 investments of \$2 million (Rs. 12 crore) each over a decade. Half of this was from the Chinese diaspora. We need Indians globally to invest in India.

To this point, there was a need for India to adopt the global best practices as in the U.S, Singapore and Israel. For example, there is a need to make convertible notes possible similar to the U.S. where over 300,000 angel investors invest through convertible notes.

Convertible notes are debt instruments, a signed document from a company to an angel investor, intended to convert to stock once a start-up raises a larger round of financing from a venture capital firm. This instrument is most popular way of raising first round of funding by startups in Silicon Valley. (Source: Forbes India Report, 2015)

The most compelling reason for Indian entrepreneurs to move their headquarters is the ease of doing business in Singapore. The Southeast Asian nation topped the World Bank’s Doing Business 2013 survey of 185 countries. India is ranked 132. In terms of starting a business, the city-state is ranked fourth while India comes in at 173. The World Bank survey also notes that it takes three permits and three days to start a business in Singapore. In comparison, it takes 12 approvals and 27 days to start a business in India.

The new rules allow for better listing norms, lock-in conditions and IPO pricing rules. For instance while current norms assume a main board with promoters, debt (bankers) and retail IPO investors, the new norms assume an entrepreneur, equity investors (like VC funds) and qualified IPO investors.

SEBI will create the separate institutional trading platform and link it to India’s existing two stock exchanges. For the listing, the regulator relaxed the mandatory lock-in period for all pre-listing investors to six months, compared with three years for other companies. Disclosure requirements have been relaxed. The minimum sum that retail investors can invest in the startups is 1 million rupees (about \$16,000).

The institutional trading platform is a welcome move to ensure broader access to capital to next generation startups. The proposed shorter lock-in periods, simplified disclosure norms, and more liberal valuation parameter disclosure norms should hopefully encourage many Indian technology companies to consider listing on this new platform to access accredited and institutional investors.

### **Venture Capital Funding**

India also has a relatively shallow funnel when it comes to venture funding. A large fraction of funding has gone to small ticket, early stage financing with little follow up. Seventy-five per cent of disclosed deals were below \$10 million and only 5 per cent over \$100 million. In contrast, the US saw a more balanced distribution of funds with 33 per cent of deals in early stage, 41 per cent in expansion stage (typically \$10-100 million) and 25 per cent in late stage. Barring a handful of high-profile e-commerce players that have dominated recent headlines, most Indian startups experience a crunch in post seed round financing. Only 22 per cent go on to do a series A (vs 56 per cent in the US).

India still lacks an exit pipeline that ultimately powers vibrant ecosystems by creating the right incentives for investors, founders and employees alike. IPOs have been less than a trickle with literally three poster successes over the last decade (InfoEdge, MakeMyTrip and JustDial), compared with eight domestically listed tech IPOs in China in the first quarter of 2015 alone. There's a growing queue of "IPO ready" Indian tech companies but it's unlikely these will be listed on local bourses. The pace of strategic M&A is gradually increasing. Virtually, every Silicon Valley biggie (Facebook, Google, Amazon, and recently Twitter) has made an Indian purchase. Certain local players are reaching acquiring scale. Snapdeal alone made eight acquisitions since 2014. But deal sizes remain low. According to ISpirit, the average exit in India (\$11 million) during 2011-14 dwarfed those in Israel (\$113 million) and the US (\$57 million). India has undoubted potential to become a global tech product powerhouse. Software products offer new promise where IT-enabled services struggle with restrictive host government visa policies and eroding cost advantages. They also hold tremendous potential to empower millions be it through mobile banking and payments, digitisation of government services, or e-commerce between needy buyers and sellers. Over the past few months, I have met several young, promising teams furiously building products that could rival any in the Valley. We need to make good on their efforts. These trends have catalysed a broader startup ecosystem. At its heart is a vibrant community of 'funders' including angels, accelerators, funds, and strategics (importantly, including corporations) that find, fund and scale startups. The number of active VCs in the country has risen from 49 in 2010 to 222 in 2014, with 40 new global funds slated to enter the country this year.

More inclusive crowdfunding models - only recently introduced in the US but quickly transplanted here - promise to direct higher levels of retail investment to the sector, especially as Sebi develops a regulatory framework to oversee alternative financing and listings of startups. Another key development has been the entry of global strategic investors, accompanied with larger financing, shorter investment cycles, and an infusion of global expertise and customer access. Perhaps the most tangible result of these virtuous

dynamics is the unprecedented \$5 billion in 2014 venture funding directed across 300-plus investments. This represents a three-time increase over the previous year, and is already a quarter of the far more mature US market. Funding is also more regionally spread out.

The top three hubs - Bengaluru, Delhi and Mumbai - accounted for 30 per cent, 25 per cent and 18 per cent of deals, respectively (and 41 per cent, 30 per cent and 12 per cent of deal flow, respectively). There are also indications of relative specialisation in core technology, e-commerce and mediatech, respectively. VC deals in the US are still heavily concentrated in Silicon Valley - where the number is three times higher than in New York, or five times higher than in Boston or LA. Such skewed growth is proving to be disruptive to local communities as well as to regional labour and real estate markets.

## **CONCLUSION**

India is on the path of becoming the world's fastest growing mobile app market where startups, financial institutes and even traditional companies are doing their best to keep up with the fast changing times. The app revolution presents incredible opportunities in several different spaces including communication, payments, and collaboration. In a move that is likely to boost India's startup ecosystem, the country's stock market regulator SEBI will launch a new trading platform and ease rules to allow startups to list and raise funds on its domestic stock exchanges. The move establishes that India is waking up, albeit late, and trying to stem the tide of technology and e-commerce startups that are moving overseas to countries like Singapore and the United States to tap the capital markets.

The changes are expected to come into effect by the end of the year. India has a few thousand startups and is often ranked among the top countries in the world for entrepreneurship. Global investors such as Tiger Global, SoftBank, Sequoia and Accel have invested in startups, including in domains like mobility and data analytics, as well as e-commerce startups offering online retail, digital payments and cab summoning services.

But despite the optimism that currently pervades India's technology startup scene, only 13% of stock market valuation in India is from the technology sector as compared with over 40% in the United States, says software product thinktank, iSPIRT.

Deep technology ventures warrant long gestation periods, need large injections of capital upfront for R&D and are often unable to evidence revenue let alone profits for several years. These firms have been excluded from accessing capital via regular stock exchange listing because of stiff listing norms such as profitability for three years, which they are unable to meet. Not all companies are talking openly about moving to Singapore. Until now, India's regulatory regime was so off-putting that startups like online retailer Flipkart and digital advertising network InMobi have re-domiciled in Singapore. Over half of all startups to receive early-stage funding in India are expected to re-domicile to Singapore because regulations there make it easy for companies to receive global venture funding.

Then, such startups look to list on foreign stock exchanges, a trend that the regulator is trying to staunch.



**REFERENCES**

- [1] Audretsch, D. B. and Lehmann, E. (2004). Financing high-tech growth: the role of banks and venture capitalists. *Schmalenbach Business Review*, Vol. 56, pp. 340–357.
- [2] Barry, Christopher B. (1994). New Direction in Research on Venture Capital Finance. *Financial Management*, 23(3) pp.3-15.
- [3] Barry, C., Muscarella, C., and Vetsuypens, M. (1990). The Role of Venture Capital in the Creation of Public Companies: Evidence from the Going-Public Process. *Journal of Financial Economics*, Vol.27: 447–472.
- [4] Bentone E. Cup. (1983). *Principles of Financial Management*. John Wiley & Sons, New York, pp.418-422.
- [5] Block, Z. and MacMillan, I. (2003). *Corporate Venturing: Creating New Business within the Firm*. Boston, MA: Harvard Business School Press.
- [6] Block, Z. and Ornati, O. A. (1997). Compensating corporate venture managers. *Journal of Business Venturing*, Vol. 2, pp. 41–51.
- [7] Bottazzi, L., Da Rin, M. and Hellmann, T. (2008). Who are the active investors? Evidence from venture capital. *Journal of Financial Economics*.
- [8] Gorman, M. & Shalman, W. (1989). What Do Venture Capitalists Do? *Journal of Business Venturing*, 4(4), pp. 231-248.
- [9] Grave, Timmons. (1992). *Venture Capital at the Crossroads*. Boston, MA: Harvard Business School Press.
- [10] Gupta, A. & Sapienza, H. (1992). Determinants of venture capital firms' preferences regarding the industry diversity and geographic scope of their investments. *Journal of business venturing*, Vol. 7, PP 347-362.
- [11] Halsbury's law. (May 2008). An article, "Venture capital and private equity: an impetus to Indian Economy", pp. 25-31.
- [12] Hellmann, T & Puri, M. (2000). The Interaction Between Product Market and Financing Strategy: The Role of Venture Capital. *The Review of Financial Studies*, 13(4), pp. 959-984.
- [13] Mehar Ridhima. (2008). Venture Capital: Challenges and scope ahead in India. *Bauddhik: The Journal of Management*, volume 1, Issue 2.
- [14] Metrick Andrew, Yasuda Ayako. (2011). Venture Capital and Other Private Equity: a Survey. *European Financial Management*, Vol. 01, No. 1, 1–36 date of issue: 10.11.11/j.1468-036X.2011.00606.
- [15] Milanov Hana. (2005). Examination of Foreign Venture Capitalists' Role in Developing Economies. *Privredna Kretanja, ekonomska politika* 103/2005, pp. 51-71.
- [16] Nagaraja N. & Srinivas K. T. (2013). Venture capital finance- a study with special reference to KITVEN funds. *International Journal of advanced research in management*, ISSN 0976-6324, volume 4, Issue 1, January- April 2013, pp. 01-10.
- [17] Sapienza H.J. (1992). When Do Venture Capitalists Add Value. *Journal of Business Venturing*, Vol. 7, pp. 9-27.
- [18] Satyanarayana T. Chary. (2005). *Venture capital, concepts & applications*. Macmillan India ltd., pp. 2-13.
- [19] Sethi, Sudhir. (2001). Venture Capital - Sustaining the Momentum, in *The Hindu – Survey of Indian Industry 2001*. Chennai, Kasturi & Sons Ltd., pp. 83 & 85.

- [20] Sharma, Adesh. (July 1999). Investment and Financing in Pesticides Industry in India. Indian Journal of Finance and Research, Vol.5. No.2, pp. 67-83.
- [21] Singh, Jagdeep Bachhar. (2000). Venture capitalists investment criteria in technology based new ventures. A doctoral thesis, Ontario, Canada, Free Press waterloo.
- [22] Singhani, Ram, M. The Business of Venture Capital: Insights from Leading Practitioners on the Art of Raising a Fund, Deal Structuring, Value Creation, and Exit Strategies. Willey, (3rd Ed.).

### **Websites**

- [1] [www.indiavca.org](http://www.indiavca.org) (accessed September 15, 2011)
- [2] [www.sebi.gov.in](http://www.sebi.gov.in) (accessed September 18, 2011)
- [3] [www.moneycontrol.com](http://www.moneycontrol.com) (accessed September 20, 2011)
- [4] [http://business.gov.in/business\\_financing/venture\\_capital.php](http://business.gov.in/business_financing/venture_capital.php) (accessed January 10, 2012)
- [5] <http://dl.is.vnu.edu.vn/bitstream/123456789/269/1/introduction-to-researchmethods.pdf>, 2003, (Web accessed on 10 July, 2012)
- [6] [www.indiajuris.com](http://www.indiajuris.com) (accessed February 3, 2012)
- [7] [www.Canbankventure.com](http://www.Canbankventure.com) (accessed March 13, 2012)
- [8] [www.catamaranventure.com](http://www.catamaranventure.com) (accessed March 15, 2012)
- [9] [www.dfj.com](http://www.dfj.com) (accessed April 10, 2012)
- [10] [www.gtvlttd.com](http://www.gtvlttd.com) (accessed April 15, 2012)
- [11] [www.inventuscap.com](http://www.inventuscap.com) (accessed April 19, 2012)



**SECTION 2**

**Changing Paradigms of Economy**



# A Case Study on Political – Socio-Economic Scenario in November 2016 Post Demonetization: Technological Transformation by Cashless Economy Through Digital India

RAJEEV SIJARIYA<sup>1</sup>

## Abstract

*The demonetisation of ₹500 and ₹1,000 banknotes was a policy enacted by the Government of India on 8 November 2016. All ₹500 (US\$7.40) and ₹1,000 (US\$15) banknotes of the Mahatma Gandhi Series ceased to be legal tender in India from 9 November 2016.*

*The announcement was made by the Prime Minister of India Narendra Modi in an unscheduled live televised address at 20:15 Indian Standard Time (IST) on 8 November. In the announcement, Modi declared that use of all ₹500 and ₹1,000 banknotes of the Mahatma Gandhi Series would be invalid from midnight of the same day and announced the issuance of new ₹500 and ₹2,000 banknotes of the Mahatma Gandhi New Series in exchange for the old banknotes. However, the banknote denominations of ₹100, ₹50, ₹20, ₹10 and ₹5 of the Mahatma Gandhi Series remained legal tender and were unaffected by the policy.*

*The government claimed that the demonetisation was an effort to stop counterfeiting of the current banknotes allegedly used for funding terrorism, as well as a crack down on black money in the country. The move was described as an effort to reduce corruption, the use of drugs, and smuggling. However, in the days following the demonetization, banks and ATMs across the country faced severe cash shortages. The cash shortages had detrimental effects on a number of small businesses, agriculture, and transportation, while people seeking to exchange their notes had lengthy waits, and several deaths were linked to the rush to exchange cash. Also, following Modi's announcement, the BSE SENSEX and NIFTY 50 stock indices crashed for the next two days.*

*The demonetisation received support from several bankers as well as from some international commentators, although it was criticised by members of the opposition parties, which led to debates in both houses of parliament and triggered organised protests against the current government in front of the parliament and elsewhere across India.*

**Keywords:** *Demonetisation, Legal Tender, Black Money, Corruption, Terrorism*

## INTRODUCTION

The government claimed that the demonetisation was an effort to stop counterfeiting of the current banknotes allegedly used for funding terrorism, as well as a crack down on black

<sup>1</sup> Professor & Director, Institute of Business Studies, CCS University Campus, Meerut  
E-mail: rajeevsijariya@gmail.com

money in the country. The move was described as an effort to reduce corruption, the use of drugs, and smuggling. However, in the days following the demonetisation, banks and ATMs across the country faced severe cash shortages. The cash shortages had detrimental effects on a number of small businesses, agriculture, and transportation, while people seeking to exchange their notes had lengthy waits, and several deaths were linked to the rush to exchange cash. Also, following Modi's announcement, the BSE SENSEX and NIFTY 50 stock indices crashed for the next two days.

The demonetisation received support from several bankers as well as from some international commentators, although it was criticised by members of the opposition parties, which led to debates in both houses of parliament and triggered organised protests against the current government in front of the parliament and elsewhere across India.

### **BACK GROUND FOR THE DEMONETIZATION**

Historically, previous Indian governments had demonetised bank notes. In January 1946, banknotes of 1,000 and 10,000 rupees were withdrawn and new notes of 1,000, 5,000 and 10,000 rupees were introduced in 1954. The Janata Party coalition government had again demonetised banknotes of 1,000, 5,000 and 10,000 rupees on 16 January 1978 as a means to curb counterfeit money and blackmoney.

In 2012, the Central Board of Direct Taxes had recommended against demonetisation, saying in a report that "demonetisation may not be a solution for tackling black money or economy, which is largely held in the form of benami properties, bullion and jewellery". According to data from income tax probes, black money holders keep only 6% or less of their ill-gotten wealth as cash, hence targeting this cash may not be a successful strategy

On 28 October 2016 the total banknotes in circulation in India was 17.77 trillion (US\$260 billion). In terms of value, the annual report of Reserve Bank of India (RBI) of 31 March 2016 stated that total bank notes in circulation valued to 16.42 trillion (US\$240 billion) of which nearly 86% (around 14.18 trillion (US\$210 billion)) was 500 and ,000 banknotes. In terms of volume, the report stated that 24% (around 22.03 billion) of the total 90266 million banknotes were in circulation.

On 8 November 2016, an announcement was made by the Prime Minister of India Narendra Modi in an unscheduled live televised address to the nation at 20:15 IST. In the announcement, Modi declared circulation of all 500 and 1,000 banknotes of the Mahatma Gandhi Series as invalid effective from the midnight of the same day, and announced the issuance of new 500 and 2,000 banknotes of the Mahatma Gandhi New Series in exchange for the old banknotes.

After the official announcement by Prime Minister Modi, the Governor of the Reserve Bank of India, Urjit Patel, and Economic Affairs secretary, Shaktikanta Das explained in a press conference that while the supply of notes of all denominations had increased by 40% between 2011 and 2016, the 500 and 1,000 banknotes increased by 76% and 109% respectively in this period owing to forgery. This forged cash was then used to fund terrorist activities against India. As a result the decision to eliminate the notes had been taken

Patel also informed that the decision had been made about six months ago, and the printing of new banknotes of denomination 500 and 2,000 had already started. However, only the top members of the government, security agencies and the central bank were aware of the move. But media had reported in October 2016 about the introduction of 2,000 denominations well before the official announcement by RBI. This statement has led to much debate, because the Reserve Bank governor six months before the announcement was Raghuram Rajan, while the new banknotes have the signature of the newly appointed governor, Urjit Patel.

### **EXCHANGING OLD NOTES**

The Reserve Bank of India laid down a detailed procedure for the exchange of the demonetised banknotes with new 500 and 2000 banknotes of the Mahatma Gandhi New Series and 100 banknotes of the preceding Mahatma Gandhi Series. Following are the key points:

- Citizens will have until 30 December 2016 to tender their old banknotes at any office of the RBI or any bank branch and credit the value into their respective bank accounts.
- Cash withdrawals from bank accounts were restricted to 10,000 INR per day and 20,000 INR per week per account from 10 to 13 November 2016. This limit was increased to INR 24,000 per week from 14 November.
- For immediate cash needs, the old banknotes can be exchanged for the new INR 500 and INR 2,000 banknotes as well as INR 100 banknotes over the counter of bank branches by filling up a requisition form along with a valid ID proof. This exchange is restricted to once per person.
- Initially, the limit was fixed at INR 4,000 per person from 8 to 13 November 2016.
- This limit was increased to INR 4,500 per person from 14 to 17 November 2016.
- The limit was reduced to INR 2,000 per person from 18 November 2016.
- Initially, all ATMs were dispensing banknotes of only INR 50 and INR 100 denominations and cash withdrawals from ATMs were restricted to INR 2000 per day. From 14 November onwards, ATMs recalibrated to dispense new INR 500 and INR 2000 notes will allow a maximum withdrawal of INR 2,500 per day, while other ATMs dispensing banknotes of only INR 50 and INR 100 denominations will allow a maximum withdrawal of INR 2000 per day.

However, exceptions were given to petrol, CNG and gas stations, government hospitals, railway and airline booking counters, state-government recognised dairies and ration stores, and crematoriums to accept the old INR 500 and INR 1,000 banknotes until 11 November 2016, which was later extended to 14 November 2016 and once again to 24 November 2016. International airports were also instructed to facilitate an exchange of notes amounting to a total value of INR 5,000 for foreign tourists and out-bound passengers.

Under the revised guidelines issued on 17 November 2016, families were allowed to withdraw INR 250,000 for wedding expenses from one account provided it was KYC compliant. The rules were also been changed for farmers who are permitted to withdraw INR 25,000 per week from their accounts against crop loan.



## **VIEWS OF DIFFERENT INDUSTRY PERSONNEL**

The decision met with mixed reactions. Several bankers like Arundhati Bhattacharya (Chairperson of State Bank of India), Chanda Kochhar (MD & CEO of ICICI Bank) and Deepak Parekh (Chairman of HDFC) appreciated the move in the sense that it would help curb black money. Businessmen Anand Mahindra (Mahindra Group), Sajjan Jindal (JSW Group), Kunal Bahl (Snap deal and Free Charge) also supported the move adding that it would also accelerate e-commerce. Infosys founder N. R. Narayana Murthy praised the move.

Finance Minister Arun Jaitley said that demonetisation would clean the complete economic system, increase the size of economy and revenue base. He mentioned the demonetisation along with the upcoming Goods and Services Tax (GST) as “an attempt to change the spending habit and lifestyle.”

The Indian National Congress spokesperson Randeep Surjewala welcomed the move but remained sceptical on the consequences that would follow. Chief Minister of Bihar Nitish Kumar supported the move. The demonetisation also got support from Chief Minister of Andhra Pradesh Nara Chandrababu Naidu. Former Chief Election Commissioner of India S. Y. Quraishi said demonetisation could lead to long term electoral reforms. Indian social activist Anna Hazare hailed demonetisation as a revolutionary step. The President of India Pranab Mukherjee welcomed the demonetisation move by calling it bold step. The opinion of the masses varied both ways on micro-blogs and social media sites like Twitter. In general, the move to demonetise and try to hinder black money was appreciated, but the manner in which it was carried out by causing hardships to common people was criticised.

### **Criticism**

On 8 November 2016, Chief Minister of West Bengal Mamata Banerjee called the new declaration “drama”. A Public Interest Litigation (PIL) was filed in Madras High Court by M Seeni Ahamed, General Secretary of the Indian National League, to scrap the decision. The High Court dismissed the PIL stating that it could not interfere in monetary policies of the government. Similar PILs were also filed in the Supreme Court of India. Supreme Court of India is yet to decide on the matter. It is listed for hearing on 2nd December 2016. Former World Bank Chief Economist, Kaushik Basu, said that the ‘damage’ is likely to be much greater than any possible benefits.

Prabhat Patnaik, a former professor of economics at the Jawaharlal Nehru University, Delhi called the move ‘witless’ and ‘anti-people’. He criticised the simple way in which black money was assumed as “a hoard of cash”, saying that it would have little effect in eliminating “black activities” while “causing much hardship to common people.”

### **Opposition**

A Congress-led opposition, which includes 13 political parties, opposed the current government on the demonetisation issue in the Winter Session of Parliament on 16 November 2016. The Chief Minister of West Bengal Mamata Banerjee also met the President Pranab Mukherjee to oppose the demonetisation. The debate on demonetisation

is known to be initiated by Indian National Congress and Anand Sharma in Rajya Sabha on 16 November 2016 while Mamata Banerjee is known to be the first to oppose the current government on the demonetisation.

On 17 November 2016, in a rally against demonetisation of ₹500 and ₹1000 notes, led by the Chief Minister of Delhi Arvind Kejriwal and his West Bengal counterpart Mamata Banerjee at Azadpur Mandi, the biggest vegetable and fruits wholesale hub in the national capital, Arvind Kejriwal demanded the withdraw of demonetisation in 3 days, or else there would be a rebellion, he said. Mamata Banerjee also stated “I give the government 3 day ultimatum, fix things or withdraw the demonetisation scheme”.

In the demonetisation debate on the second and third day of the Winter Session of Parliament at the Rajya Sabha, on 17 and 18 November 2016, the opposition and the current government clashed over the demonetisation issue, bringing the house to continuous halts.

On 24 November 2016, in the demonetisation debate in Rajya Sabha, the former prime minister of India Manmohan Singh said “this scheme will hurt small industries, the farming sector. The GDP can decline by about 3 per cent due to this move”, while he also questioned “I would like to ask the Prime Minister examples of countries where people have deposited their money in the banks and not allowed to withdraw their own money.” and later also said “It is no good that on each day banks bring out new notifications. It doesn’t reflect properly on Prime Minister’s Office, Finance Minister and the Reserve Bank of India. Cooperative banking system has been prevented from handling cash” Singh at last termed the demonetisation move as an “organized loot, legalized plunder of the common people”.

## **EFFECTS AND AFTERMATH**

The scarcity of cash due to demonetisation led to chaos, and most people holding old banknotes, faced difficulties to exchange them as endless lines outside banks and ATMs across India, became a daily routine for millions of people waiting to deposit or exchange the INR 500 and INR 1000 banknotes since 9 November ATMs were running out of cash after a few hours of being functional, and around half the ATMs in the country were non-functional Sporadic violence was reported in New Delhi, but there were no reports of any grievous injury, people attacked bank premises and ATMs and a ration shop was looted in Madhya Pradesh after the shop owner refused to accept INR 500 banknotes.

Several people were reported to have died from standing in queues for hours to exchange their old banknotes. Deaths were also attributed to lack of medical help due to refusal of old banknotes by hospitals. As of 15 November 2016, the attributed death toll was 25. In an interview, Chief Minister of Delhi Arvind Kejriwal lashed out at a BBC reporter who asked him to justify his 19 November claim that 55 deaths were linked to demonetisation While, the CMD of Punjab National Bank said that panic after demonetisation started fading on 19 November 2016.

## **Stock Market Crash**

As a combined effect of demonetisation and US presidential election, the stock market indices dropped to an around six-month low in the week following the announcement. The

day after the demonetisation announcement, BSE SENSEX crashed nearly 1,689 points and NIFTY 50 plunged by over 541 points. By the end of the intraday trading session on 15 November 2016, the BSE SENSEX index was lower by 565 points and the NIFTY 50 index was below 8100 intraday.

### **Transportation Halts**

After the demonetisation was announced, about 800,000 truck drivers were affected with scarcity of cash, with around 400,000 trucks stranded at major highways across India were reported. While major highway toll junctions on the Gujarat and Delhi-Mumbai highways also saw long queues as toll plaza operators refused the old banknotes.

Nitin Gadkari, the Minister of Transport, subsequently announced a suspension of toll collections on all national highways across India until midnight of 11 November, later extended until 14 November and again until midnight of 18 November, and yet again till 2 December.

### **BUSINESS**

By the second week after demonetisation of INR 500 and INR 1,000 banknotes, cigarette sales across India witnessed a fall of 30–40% while E-commerce companies saw up to a 30% decline in cash on delivery (COD) orders. Several e-commerce companies hailed the demonetisation decision as an impetus to an increase in digital payments. They believe that it would lead to a decline in COD returns which is expected to cut down their costs.

The demand for point of sales (POS) or card swipe machines has increased. E-payment options like PayTM and PayUMoney has also seen a rise. According to data of Pine Labs, the demand for its POS machines doubled after the decision. Further it states that the debit card transactions rose by 108% and credit card transactions by 60% on 9 November 2016.

### **INCOME TAX RAIDS AND CASH SEIZURES**

The Finance Ministry instructed all revenue intelligence agencies to join the crackdown on forex traders, hawala operators and jewellers besides tracking movement of demonetised currency notes.

Income Tax departments raided various illegal tax-evasive businesses in Delhi, Mumbai, Chandigarh, Ludhiana and other cities that traded with demonetised currency. The Enforcement Directorate issued several FEMA notices to forex and gold traders. It also raided several forex establishments making back dated entries. Large sum of cash were seized in different parts of the country. In Chhattisgarh liquid cash worth of ₹4.4 million (US\$65,000) was seized.

### **CONCLUSION**

The decision taken by the Government of India has a huge success response for the person who is not at all corrupted but it will depend upon how well it will be concluded and included in society reforms for the self upliftment. The citizen of India will be highly cooperative as they are doing now and the future aspects of the demonetization will bring

out country to the new heights. The demonetization scheme in long run will be an asset to our country and this policy should be repeated on the 5 year basis from now to make India a developed country.

## REFERENCES

- [1] “Here is what PM Modi said about the new Rs 500, Rs 2000 notes and black money”. *India Today*. 8 November 2016. Retrieved 9 November 2016.
- [2] “Notes out of circulation”. *The Times of India*. 8 November 2016.
- [3] “Corruption fight”. *First post*. 12 November 2016.
- [4] “BJP policy”. *The Times of India*. 10 November 2016.
- [5] “India demonetisation: Chaos as ATMs run dry”. *Al Jazeera*. Retrieved 9 November 2016.
- [6] “Demonetisation: Chaos grows, queues get longer at banks, ATMs on weekend”. 12 November 2016.
- [7] “India: Demonetisation takes its toll on the poor”. *Al Jazeera*. 16 November 2016. Retrieved 17 November 2016.
- [8] “Demonetisation Death Toll Rises To 25 And It’s Only Been 6 Days”. *huffingtonpost*. Retrieved 15 November 2016.
- [9] “Sensex crashes 1,689 points on black money crackdown, U.S. election”. *The Hindu*. Retrieved 9 November 2016.
- [10] “Demonetisation: Opposition calls for countrywide protest on November 28”. *The Indian Express*. Retrieved 23 November 2016.
- [11] “Demonetisation: Opposition parties join hands, to hold ‘protest day’ on November 28”. *The Indian Express*. Retrieved 24 November 2016.
- [12] “‘Demonetisation protest sure to succeed with people’s support’”. *The Economic Times*. Retrieved 24 November 2016.
- [13] Gopika Gopakumar, Vishwanath Nair (8 November 2016). “Rs 500, Rs 1000 notes may be back, if history is a guide”. *Live Mint*. Retrieved 9 November 2016.
- [14] “At least 4 months needed to replace demonetised notes, not 50 days: Here’s why”. *The Indian Express*. 14 November 2016.
- [15] [http://dor.gov.in/sites/upload\\_files/revenue/files/Measures\\_Tackle\\_BlackMoney.pdf](http://dor.gov.in/sites/upload_files/revenue/files/Measures_Tackle_BlackMoney.pdf)
- [16] Appu Esthose Suresh (12 November 2016). “Why govt’s demonetisation move may fail to win the war against black money”. *Hindustan Times*. Retrieved 12 November 2016.
- [17] Damodaran, Harish (9 November 2016). “Are banks equipped to replace 2,300 crore pieces of Rs 500 and Rs 1,000 notes?”. *The Indian Express*. Retrieved 9 November 2016.
- [18] Kumar Uttam (12 November 2016). “The measure is ‘anti-poor’: When BJP opposed demonetisation during UPA govt”. *Hindustan Times*. Retrieved 12 November 2016.
- [19] Betwa Sharma (11 November 2016). “BJP Had A Very Different View on Demonetisation in 2014”. *Huffingtonpost.in*. Retrieved 12 November 2016.
- [20] “Explain opposition to similar move by UPA: AAP to BJP on demonetisation”. *The Indian Express*. 12 November 2016. Retrieved 12 November 2016.
- [21] “How BJP had termed demonetisation as ‘anti-poor’ in 2014”. *The Times of India*. Retrieved 12 November 2016.
- [22] IANS (2014-05-08). “Pranab launches RuPay, India’s own card payment network”. *The Hindu*. Retrieved 2014-08-14.
- [23] “Rs 500, Rs 1000 banned; Rs 2000 to come: Did we miss these Twitter, RBI hints?”. *Firstpost*. 9 November 2016. Retrieved 29 November 2016.
- [24] Saha, Manojit (26 August 2016). “What is Unified Payment Interface?”. *The Hindu*. Retrieved 30 November 2016.

- [25] “Why Were the Notes Scrapped? RBI Chief, Economic Affairs Secy Explain”. *News 18*. 8 November 2016. Retrieved 9 November 2016.
- [26] Sridhar, G Naga; Vageesh, NS (21 October 2016). “Coming soon to your wallet: ₹2,000 notes”. *Business Line*.
- [27] “Move was in the pipeline for months”. *The Hindu*. 9 November 2016. Retrieved 9 November 2016.
- [28] “Finance Ministry has reviewed the position regarding availability and distribution of all denominations of bank notes” (PDF). Ministry of Finance, Government of India. Retrieved 13 November 2016.
- [29] “Withdrawal of Legal Tender Character of existing INR 500/- and INR 1000/- Bank Notes – Revision in limits”. Reserve Bank of India. Retrieved 13 November 2016.

# The Practice of ICT in Classroom

RAJ LAKSHMI RAINA<sup>1</sup>

## Abstract

*The National Policy on Education 1986, as modified in 1992, stressed the need to employ educational technology to improve the quality of education. Thus, in the course of the most recent two decades, the rapid development of ICT has turned out to be a standout amongst the most important topics talked about by the researchers in education. This is because of the ability of ICT in providing a dynamic and proactive teaching and learning environment. In accordance with the current digital era, teachers are required to incorporate ICT in their daily teaching and replace their conventional techniques with modern tools and facilities. The principle focus of this paper is on the use of ICT integration in education. It also aims to bring together the key points related to the benefits of ICT, limitations of ICT and teacher training.*

**Keywords:** *ICT, ICT Integration, Education, Teaching and Learning Process, Teacher training*

## INTRODUCTION

The term 'Information and Communications Technology' (ICT) refers to all the devices, tools, content, resources, forums, and services, digital and those that can be converted into or delivered through digital forms, which can be deployed for realising the goals of teaching learning, enhancing access to and reach of resources, building of capacities, as well as management of the educational system. It has gone through innovations and transformed our society that has totally changed the way people think, work and live. Information and communication technologies (ICT) have become commonplace entities in all aspects of life. Across the past twenty years the use of ICT has fundamentally changed the practices and procedures of nearly all forms of endeavour within business and governance. Education is a very socially oriented activity and quality education has traditionally been associated with strong teachers having high degrees of personal contact with learners. The use of ICT in education lends itself to more student-centred learning settings. But with the world moving rapidly into digital media and information, the role of ICT in education is becoming more and more important and this importance will continue to grow and develop in the 21st century.

## ICT Integration in Education

According to Daniels (2002) ICTs have become within a very short time, one of the basic building blocks of modern society. The field of education has been affected by ICTs, which have undoubtedly affected teaching, learning, and research (Yusuf, 2005). A great deal of

---

<sup>1</sup> Assistant Professor, Amity University

research has proven the benefits to the quality of education (Al-Ansari, 2006). ICTs have the potential to innovate, accelerate, enrich, and deepen skills, to motivate and engage students, to help relate school experience to work practices, create economic viability for tomorrow's workers, as well as strengthening teaching and helping schools change (Davis and Tearle, 1999; Lemke and Coughlin, 1998; cited by Yusuf, 2005). The field of education has been affected by ICTs, which have undoubtedly affected teaching, learning and research (Yusuf, 2005). Harris (2002) concludes that the benefits of ICT will be gained "...when confident teachers are willing to explore new opportunities for changing their classroom practices by using ICT.ing. With the help of ICT, students can now browse through e-books, sample examination papers, previous year papers etc. and can also have an easy access to resource persons, mentors, experts, researchers, professionals, and peers-all over the world. This flexibility has heightened the availability of just-in-time learning and provided learning opportunities for many more learners who previously were constrained by other commitments (Young, 2002). Integrating technology in education is a complex task due to its dynamic nature. Hence planning for ICT integration in education is considered as a key element for improvement and development. ICT facilitates access to information and transmission of it; and provides a vehicle for collaborative learning and for assessment. Rosnaini Mahmud and MohdArif (2008) define "ICT integration as the process of determining *where* and *how* technology fits in the teaching and learning scenario."

Information and Communication Technologies have enabled the union of a wide array of technology based and technology mediated resources for teaching learning. It has therefore become possible to employ ICT as an omnibus support system for education. ICT enabled teaching-learning encompasses a variety of techniques, tools, content and resources aimed at improving the quality and efficiency of the teaching-learning process. Ranging from projecting media to support a lesson, to multimedia self-learning modules, to simulations to virtual learning environments, there are a variety of options available to the teacher to utilise various ICT tools for effective pedagogy. Each such device or strategy also involves changes in the classroom environment, and its bearing on effectiveness. Availability of a wide range of such teaching-learning materials will catalyse transformation of classrooms into ICT Enabled classrooms.

With Information and Communication technologies becoming more accessible, reliable and mature, the prospect of leveraging ICT for education is becoming increasingly feasible. Infact, the teachers are at the centre of curriculum change and they control the teaching and learning process. Therefore, they must be able to prepare young people for the society in which the competency to use ICT to acquire and process information is very important.

### **Benefits of Using ICT in Classroom**

ICT offers the opportunity for more student-centered teaching and serves as an individualization of learning, it Provides greater opportunity for teacher-to-teacher and student-to-student communication and collaboration, also provides opportunities to access an abundance of information using multiple information resources and viewing information

from multiple perspectives, thus fostering the authenticity of learning environments, It gives greater exposure to vocational and workforce skills for students, facilitates higher-order thinking, active, collaborative, creative, integrative, and evaluative learning as an advantage over the traditional method, creates greater enthusiasm for learning amongst students, increases the flexibility of delivery of education so that learners can access knowledge anytime and from anywhere.

## **CONCLUSION**

Therefore this paper is an attempt to present that how Information and communication technology (ICT) has become, within a very short time, one of the basic building blocks of modern society. Even though it has some limitations which can't be ignored, still many countries now regard understanding ICT and mastering the basic skills and concepts of ICT as part of the core of education, alongside reading, writing and numeracy. The adoption and use of ICTs in education have a positive impact on teaching, learning, and research. ICT can affect the delivery of education and enable wider access to the same.

In addition, it will increase flexibility so that learners can access the education regardless of time and geographical barriers. It can influence the way students are taught and how they learn. It would provide the rich environment and motivation for teaching learning process which seems to have a profound impact on the process of learning in education by offering new possibilities for learners and teachers. These possibilities can have an impact on student performance and achievement. Similarly wider availability of best practices and best course material in education, which can be shared by means of ICT, can foster better teaching and improved academic achievement of students.

Also, to make the effective use of ICT in education it is important for the teachers to be confident and competent in using various ICT tools to build their trust in the technology. Without teachers' competency and mastery skills of ICT integration which is appropriate to their needs, ICT could not be put into good use for instructional delivery. The teachers should be the main motivator and initiator of the ICT implementation at schools. They must be the part of the global change in learning and teaching modification. Therefore, education policy makers, educators and all concerned should evaluate and recognize the roles of ICT in education in order to work for the effective functioning of this technology in their education systems.

## **REFERENCES**

- [1] Bhattacharya, I. & Sharma, K. (2007), 'India in the knowledge economy – An electronic paradigm', *International Journal of Educational Management* Vol. 21 No. 6, pp. 543- 568.
- [2] MedihaTezcan., The Role of Education and ICT in Economy Proceedings of the International Conference on Human and Economic Resources, 2006, pp 338-347 from Izmir University of Economics.
- [3] Sharma Parul., Approach To ICT in Library Training, Education & Technology: Issues & Challenges. ICAL, Poster paper, 2009.



- [4] ShikshaSammelan 2009, kolkata. ICT for Quality Education, Vikramshila Education Resource Society.
- [4] Irvin R. KATZ, USA. ICT Literacy: Integration & Assessment in Higher Education. Systemics, Cybernetics and Informatics, Volume 5, Number 4, pp. 50-55.
- [5] AdeyinkaTella and Emmanuel OlusolaAdu, Nigeria. ICT & Curriculum Development: the challenges for education for sustainable development. *Indian Journal of Science and Technology*. Vol. 2, No 3 (Mar. 2009) ISSN: 0974- 6846.

# The Impact of Digitalization on Economy

MONIKA KADAM<sup>1</sup> and NEHA YADAV<sup>1</sup>

## ABSTRACT

*Digitalization, in today's era spreading across every aspect of our daily lives in all possible ways. Digital infrastructure all through the country is like a utility to the Indian people as it will make available high speed internet delivering all the government services with ease and fast. Digital empowerment of Indian people will really make possible of digital literacy through universally accessible digital resources. "Digital India" is a campaign launched by Prime Minister Narendra Modi on 1st July 2015 to ensure that government services are made available to citizens electronically by increasing internet connectivity or by making the country digitally empowered. Digitally transformed services will also promote people for doing online business by making financial transactions easy, electronic and cashless. The Department of Electronics and Information Technology anticipates that this program will have a huge impact on the Ministry of Communication and IT. The program is projected at Rs 1,13,000 cr. which will prepare the country for knowledge-based transformation. It will focus on providing high speed internet services to its citizens and make services available in real time for both online and mobile platform. Mobile and internet banking can improve the financial inclusion in the country and can create win-win situation for all parties in the value-chain by creating an interoperable ecosystem and revenue sharing business models. Therefore, this paper dedicates on the Digital India campaign where technologies and connectivity will come together to make an impact on all aspects of governance and improve the quality of life of citizens.*

## INTRODUCTION

Digital India is an initiative of Government of India launched on 1<sup>st</sup> July 2015 by Prime Minister Narendra Modi to ensure that Government services are made available to citizens electronically by improved online infrastructure and by increasing Internet connectivity or by making the country digitally empowered in the field of technology.

It plans to connect rural areas with high-speed internet networks. Digital India focuses on three core components which are:

- The create and develop improved country's digital infrastructure to connect every citizen of the country at every where
- To facilitate digital delivery of services and availability of all documents of citizens on the cloud platform
- Digital Empowerment and encouraging the citizens for cashless transactions.

---

<sup>1</sup> Assistant Professor, RBMI, Greater Noida

Digital India programme has a vision for an inclusive growth in areas of electronic services, products, manufacturing and job opportunities etc. This programme focuses to help India gain a better rural connectivity in stable governmental policies. Simultaneously the initiative is designed to create jobs and enhance skill development which will ultimately lead to increase in GDP and revenues from tax. The consumers will be benefited by way of saving time, money, physical & cognitive energy spent in lengthy government processes. For e.g. digital ticketing will lead to reduction in queue at ticket counter with online resources for booking, online tax-return filing etc. From smart phones to lightning-fast laptops to GPS devices, it's hard to imagine life without technology. In the twenty-first century, one of the most important technologies is the power of the digitization. Another part of digitization is the advancement of smart phones that gives the freedom of single touch to access the online services all over the globe. With Digital India project, the government is ready for the big programme by connecting every service with the e-power. This facility will aim to lessen the usage of physical documents and enable sharing of e-documents across organizations.

For the smooth execution of this program, government will enhance National Informatics Centre which is responsible to carry IT projects in government departments. For faster design, develop and implement various e-Governance projects, in at least 10 key ministries positions of Chief Information Officers (CIO) will be created and necessary senior positions within the department will be created by Department of Electronics and IT (DeitY) for managing the initiative.

It is rightly said by the hon'ble Prime Minister of India, Narendra Modi that Information Technology plays important role to make India a digital country, in his words "India Today(IT) + Information Technology(IT) = India Tomorrow(IT)".

### **Estimated Costs**

Overall Costs of Digital India initiative is approx Rs. 1.13 lakh crore for ongoing schemes as well as new schemes and activities. To jointly explore opportunities for collaboration on implementing this ambitious initiative, India and the United States have already agreed for the same.

### **Pillars of Digital India**

Specifically, the government aims to target nine 'Pillars of the Digital India' with an objective to achieve growth on multiple fronts with the Digital India Programme

1. Universal access to Internet
2. Public Internet Access Programme
3. Broadband Highways
4. e-Governance – Reforming Government through Technology
5. e-Kranti - Electronic delivery of services
6. Information for All

7. Electronics Manufacturing
8. IT for Jobs
9. Early Harvest Programmes

#### **KEY PROJECTS OF DIGITAL INDIA PROGRAMME**

1. **Digital Locker System** aims to minimize the usage of physical documents and enable sharing of e-documents across agencies. The sharing of the e-documents will be done through registered repositories thereby ensuring the authenticity of the documents online.
2. **MyGov.in** has been implemented as a platform for citizen engagement in governance, through a “Discuss”, “Do” and “Disseminate” approach. The mobile App for MyGov would bring these features to users on a mobile phone.
3. **Swachh Bharat Mission (SBM) Mobile app** would be used by people and Government organizations for achieving the goals of Swachh Bharat Mission.
4. **eSign framework** would allow citizens to digitally sign a document online using Aadhaar authentication.
5. The **Online Registration System (ORS)** under the eHospital application has been introduced. This application provides important services such as online registration, payment of fees and appointment, online diagnostic reports, enquiring availability of blood online etc.
6. **National Scholarships Portal** is a one stop solution for end to end scholarship process right from submission of student application, verification, sanction and disbursal to end beneficiary for all the scholarships provided by the Government of India.
7. DeitY has undertaken an initiative namely **Digitize India Platform (DIP)** for large scale digitization of records in the country that would facilitate efficient delivery of services to the citizens.
8. The Government of India has undertaken an initiative namely **Bharat Net**, a high speed digital highway to connect all 2.5 lakh Gram Panchayats of country. This would be the world’s largest rural broadband connectivity project using optical fibre.
9. BSNL has introduced **Next Generation Network (NGN)**, to replace 30 year old exchanges, which is an IP based technology to manage all types of services like voice, data, multimedia/ video and other types of packet switched communication services.
10. BSNL has undertaken large scale deployment of Wi-Fi hotspots throughout the country. The user can latch on the BSNL Wi-Fi network through their mobile devices.
11. To deliver citizen services electronically and improve the way citizens and authorities transact with each other, it is imperative to have ubiquitous connectivity.

The government also realises this need as reflected by including ‘**broadband highways**’ as one of the pillars of Digital India. While connectivity is one criterion, enabling and providing technologies to facilitate delivery of services to citizens forms the other.

## **OBJECTIVES**

- To understand the concept of Digital India Campaign
- To know how Digital India Campaign will make an impact on all aspects of governance and improve the quality of life of citizens.
- To find the impacts of Digitalization on the Indian economy
- To explain the challenges faced by Digital India Programme

## **RESEARCH METHODOLOGY**

Type of Research- Descriptive Research

For this research purpose secondary data is used to analyse and gain in-depth knowledge about Digital India campaign. Secondary data has been collected from central government official websites, journals, newspapers and related studies.

### **Impact of Digitalization on Economy**

- Around 12,000 rural post office branches have been linked digitally and soon payment banking would also become a reality for them.
- The ‘digital village’ concept started government by linking all schemes with technology. The ‘digital village’ would be powered by LED lighting, solar energy, skill development centres and e-services like e-education and e-health.
- E-transactions related to e-governance projects in the country have almost doubled in 2015
- The focus on ‘Make in India’ have played significant roles in the occurrence of the digitalization.

## **SCOPE OF DIGITAL INDIA**

- The digitalization initiates many schemes like e-Health, e-Sign, e-Education etc.
- All the government department will be integrated with optical fibre, which will improve operability of these organisations. It will also result in real time service delivery from online platform.
- More employment prospects will open for the youth that will boost the nation’s economy.

## **IMPACT OF DIGITAL INDIA**

### **A. Impact on Economy**

The Digital India plan could increase GDP up to \$1 trillion by 2025. It can play a key role in macro-economic factors such as GDP growth, employment generation, labor productivity, growth in number of businesses and revenue leakages for the Government.

There has been a 10% increase in mobile and broadband penetration increases the per capita GDP by 0.81%. India is the 2nd largest telecom market in the world and world's 3rd largest Internet market. There is a huge economic opportunity in India. Future growth of telecommunication industry in terms of number of subscribers is expected to come from rural areas

### **B. Impact on Society**

Social sectors such as education, healthcare, and banking are unable to reach out to the citizens due to limitations such as middleman, illiteracy, ignorance, poverty, lack of funds, information and investments. These challenges have marked differences in the economic and social status of the people in these areas.

The poor literacy rate in India is due to unavailability of physical infrastructure in rural and remote areas. According to estimates, the digital literacy in India is 6.5%. The digital India project will be helpful in providing real-time education and partly address the challenge of lack of teachers in education system through smart and virtual classrooms. Education to farmers, fisher men can be provided through mobile devices. The high speed network can provide the adequate infrastructure for online education platforms like massive open online courses (MOOCs).

Digital platforms can help farmers in know-how (crop choice, seed variety), context (weather, plant protection, cultivation best practices) and market information (market prices, market demand, logistics).

### **C. Impact on Environment**

The Digitalization will also contribute to the environmental changes.

The next generation technologies will help in lowering the carbon footprint by reducing fuel consumption, waste management, greener workplaces and thus leading to a greener ecosystem. The ICT sector helps in efficient management and usage of scarce and non-renewable resources.

Cloud computing technology minimizes carbon emissions by improving mobility and flexibility.

## **CHALLENGES OF DIGITALIZATION OF INDIAN ECONOMY**

- 1. High level of digital illiteracy:** Digital illiteracy is prevalent in most of the towns and villages in India. Cities have adopted digitalization but limited to certain extent. Digitalization is cashless transaction on daily basis, use of internet services to get

government certificates. So it's a team work which includes citizen's responsibility and support to the new system.

2. **Connectivity to remote areas:** It is a mammoth task to have connectivity with each and every village, town and city. The problem of connectivity is a complex issue because every state has different laws pertaining to its execution. Also it is challenging for the central authorities to make a database where such a huge information can be stored.
3. **Compatibility with center state databases:** Every state has different internet protocols because every state is diversified. Diversified not only in the sense of religion but also in language. Hence software compatibility with the center is a crucial issue. Information shall be saved carefully.
4. **Cyber Crime:** There is cyber threat all over the globe and digital India will not be any exception. Hence we need a strong anti cyber crime team which maintains the database and protects it round the clock
5. **Inter Departmental Co ordination:** Within the government there are various departments which should be integrated. Integration has technical as well as corporate issue. Corporate in the sense self ego of the officers and staff of our government services are hurdle in the change. Also the middle man policy will be eliminated completely because of digital India, hence there will be imminent resistance from the working staff.
6. **Finance:** Though there are resources with India but there is a huge capital cost which is to be invested and the fruits of the investment will be received after few years.
7. **Net neutrality:** The issue is still on the table and we are blindly following the digital India. Net neutrality is must and we should make sure that digital India without net neutrality would be a great blow to entrepreneurs and citizens of India.
8. **Changing the mindset:** This point will come into picture when you have allocated the required resources and material but when it comes to implementing them, most of them will be hesitant to change. People are accustomed with years of same of practice that they are not ready to change.
9. **Exchange of information:** The information stored should also be used by other government offices. For example police, surveillance and other security issues can be easily resolved with digital India but its co ordination is a mammoth task. It is not only a technological question but also deals with the question of privacy and security.

## CONCLUSION

Digitalization is a welcome step in shaping India of the 21st century powered by connectivity and the technological opportunity. A digitally connected India can help in improving social and economic condition of people through development of non-agricultural economic

activities apart from providing access to education, health and financial services. A digitally connected India can help in improving social and economic condition of people through development of non-agricultural economic activities apart from providing access to education, health and financial services.

#### **BIBLIOGRAPHY**

- [1] [http://deity.gov.in/sites/upload\\_files/dit/files/Digital%20India.pdf](http://deity.gov.in/sites/upload_files/dit/files/Digital%20India.pdf).
- [2] [https://en.wikipedia.org/wiki/Digital\\_India](https://en.wikipedia.org/wiki/Digital_India)
- [3] <http://digitalindiamib.com/index.html>
- [4] <http://indianexpress.com/article/india/india-others/cabinet-clears-digital-india-programme/>



# Role of Media in Making India a Cashless Economy: An Overview

KAMALJEET KAUR<sup>1</sup>

## Abstract

*The Economy is a very Sensitive Organ.*

*Hjalmar Schacht*

*The economy of a country is a sensitive organ which builds the image of a nation worldwide. Every Nation desires that its economy should grow with the time. Indian finance ministry's step towards cashless economy is the sign of the growth of Country's Economy. Although it was imposed not introduced but still it is praiseworthy step. But due to India's lifestyle and culture there are many obstacles in making India a Cashless Economy. These obstacles can be minimized with the help of Media. Media is the voice of People and works for social welfare. It also acts as a guide. In this situation it should work as a guide and motivate the society to use plastic money. In this paper we will discuss about the Role and influence of Media on the society. It will focus on the Print and Electronic Media only. The paper will emphasise that how media should act in the promotion of Cashless Economy. Media played its role during demonetization and can act as a messenger in making India a cashless Economy. The Research methodology is descriptive. The Findings of the paper describes that Media can and should play a responsible role for the implementation of Cashless Economy in India.*

**Keywords:** *Media, Cashless Economy, Implementation, Demonetization*

## INTRODUCTION

Cashless means exchange of funds by cheque, debit or credit card, or electronic methods rather than the use of cash. A cashless economy is one in which all the transactions are done using cards or digital means. Here the circulation of physical currency is minimal. It is a very common procedure for an urban literate person but Indian Government wants to make this procedure a habit of each and every citizen in India. While Media means the medium through which information is broadcasted or published. The medium can be Radio, Television, Newspaper, Magazine, Internet or Social Media (New Media). Media has unparallel influence on all the aspects of human life in present era. It performs three functions i.e. inform, influence and entertain. The impact of these functions is multidimensional.

India is a developing country where Information and Communication Technology is growing rapidly. The initial step towards cashless economy or plastic money is also a sign

---

<sup>1</sup> Associate Professor Tencia Institute of Advanced Studies, Delhi

of ICT growth. The implementation of plastic money is a herculean task especially in a Country where Cash is a status symbol, where the parents teach Children to save the Cash in Piggy Banks, where people love to flaunt the cash of their wallets, where people prefer standing in the queues rather than using ATM, Debit/ Credit Card or E- Banking. But the sudden announcement of Demonetization(November 2016) left no other option except plastic money. Plastic money is the other name of the Cashless Economy. It is the need of the hour and will help in the ICT growth of India. India uses too much cash for transactions. The ratio of cash to gross domestic product is one of the highest in the world—12.42% in 2014, compared with 9.47% in China or 4% in Brazil. Less than 5% of all payments happen electronically. India continues to be driven by the use of cash; less than 5% of all payments happen electronically however the finance minister, in 2016 budget speech, talked about the idea of making India a cashless society, with the aim of curbing the flow of black money.

Even the RBI has also recently unveiled a document — “Payments and Settlement Systems in India: Vision 2018” — setting out a plan to encourage electronic payments and to enable India to move towards a cashless society or economy in the future. The cashless economy will shape the future of India. But there are some hindrances in the implantation of Cashless economy.

### **HINDRANCES IN THE IMPLEMENTATION OF CASHLESS ECONOMY**

There are various hindrances in the implementation of Cashless Economy.

- Unavailability of internet connectivity in remote areas is causing great hindrances in the implementation of Cashless Economy. Cashless Economy cannot be considered without Internet because the basic requirement for E- Banking, Online transactions, Online sale and purchase, Online payments etc. is Internet connection. Unavailability of Internet Connectivity is the primary hindrance on the path of Cashless Economy.
- Another hindrance is the poor connectivity of Mobile Phones. Traders often report transaction failures when swiping customers’ cards. It happens all the time but mostly in the business peak hours of evening.
- Financial Illiteracy is also an obstacle in the way of Cashless Economy. Most of the rural population of India is financial illiterate. The dream of cashfree economy cannot be converted in reality before achieving the goal of financial literacy.
- A number of Bank accounts are lying un operational in our Country. Unless people start operating bank accounts cashless economy is not possible.
- There is also vested interest in not moving towards cashless economy.
- Our Country is dominated by small retailers or traders. They don’t have enough resources to invest in electronic payment infrastructure.
- The perception of consumers also sometimes acts as a barrier. The benefit of cashless transactions is not evident to even those who have credit cards. Cash, on the other hand, is perceived to be the fastest way of transaction. It is a commonly held belief that having cash helps you negotiate better.

- Most card and cash users fear that they will be charged more if they use cards. While, non-users of credit cards are not aware of the benefits of credit cards.
- Indian banks are making it difficult for digital wallets issued by private sector companies to be used on the respective bank websites.
- The financial status of citizens is also an hindrance as a number of people cannot afford smart phones, laptops or Personal Computers which are required for the success of Cashless Economy.

Due to these hindrances and obstacles the implementation of Cashless Economy in India is a challenging task. Beside these hindrances ; Media can play a vital role in the implementation of Cashless Economy.

### **ROLE OF MEDIA**

Media is a powerful tool of society which directly influences the society. It is the fourth estate of India. It acts as a watchdog, provides the information, serves the economic and political system and works as a community forum. In today's era people believe on Media more than human beings. From Clothes' advertisement to political parties election campaign everything reached us through Media. Even the news of Demonetization and updated notifications of RBI and Indian Government regarding the same were publicised through Media. The bomb of Demonetization was blasted on the black money holders through Television i.e. electronic Media. So Media should play his role for the implementation of Cashless Economy. Media should take following steps for the Cashless Economy:

- Media should broadcast and publish the stories about the benefits of Cashless Economy.
- There should be special debate programmes, Talk shows or Discussion Programmes for the promotion of Cashfree Economy.
- Soft Stories should be covered that how small vendors are running their business without Cash.
- Media can and should work on the awareness programmes regarding the journey of cash to less cash and to cashless.
- Short films or animations can be broadcasted about the E- Banking, E-Transactions and E- Wallets.
- Editorials, Articles and Features should be published about the different procedures of E-Transactions.
- Media should treat this task as corporate Social Responsibility.

### **CONCLUSION**

From the above mentioned points we reach on the conclusion that Media which has captured the minds of Society can play an important role in making India a cashless Economy. Media is shaping the minds of our future generations through different programmes. So it

should also spread the message in the society that how we can make our country cashless economy and how the cashless economy will be beneficial for us.

#### **REFERENCES**

- [1] <http://www.nyoooz.com/news/patna/748655/media-will-make-cashless-economy-a-success-expert>
- [2] <http://www.navhindtimes.in/obstacles-in-the-path-of-cashless-economy/>
- [3] <http://www.civildaily.com/story/cashless-society/>
- [4] <http://essaycamp.com/examples/social-impact-of-media-essay>
- [5] <http://hope.journ.wvu.edu/tpilgrim/j190/190.8functionslist.html>

# Communication, Technology and Media Revolution

AKANSHA ARORA<sup>1</sup>

## Abstract

*As in other developing countries the main focus of the Indian government is development, and communication is a key to further development. Communications can provide more equal distribution of information and allow the focusing of activities on the weaker parts of society. It can also provide knowledge so individuals, groups, and communities can develop themselves, promoting independence, self-reliance, and use of local resources. There needs to be an integration of traditional and modern communications systems.*

**Keywords:** *Information and Communication Technology (ICT), Communication Media, Revolution of Media, Education, Influence*

## INTRODUCTION

In the age of Information and communication Technologies whosoever is unaware of these terms is considered illiterate or outdated. Once obsessed with capital intensive mass media technologies development planners as well as advertisers are finding new means and tools to reach out their tech savvy target audience. Educators are engrossed in new means to use the updated technology in their class rooms. In an age when there are one billion users inter connected through facebook this is one of the most powerful participatory medium of 2 communication. In this scenario whosoever is educated and is having means to use this simple technology can't ignore it. Social media is emerging as a most vital tool of different kinds of communication which is equipped with the ability to share information, mould opinion, connecting individuals and communities and tool of active participation.

“With the rise of new media technologies and the global reach of the highly concentrated culture industries, the scope and impact of the educational force of culture in shaping and refiguring all aspects of daily life appear unprecedented. Yet the current debates have generally ignored the powerful pedagogical influence of popular culture, along with the implications it has for shaping curricula, questioning notions of high-status knowledge, and redefining the relationship between the culture of schooling and the cultures of everyday life.”

Development of technologies (such as computers, digital communication, microchips) in the second half of the 20th century that has led to dramatic reduction in the cost of obtaining, processing, storing, and transmitting information in all forms (text, graphics, audio, video).

---

<sup>1</sup> Assistant Professor, TIAS, Delhi

## **USE OF TECHNOLOGY IN COMMUNICATION**

Using technology in communication has become a necessity; it's now part of our lives. People communicate through emails, faxes, Mobile phones, texting services, video conferences, video chat-rooms and social media channels. As time goes on, more emerging technologies will change the way we communicate and it will be up to us to embrace them or not. Let's look at the impact or use of technology in communication both to individuals and businesses.

**Impact of technology in communication to a business:** Today, every business uses technology in its own way to reach the media and targeted consumers.

**Social interaction with consumers:** With the recent invention of social networks like facebook and twitter, business can create business pages then get followers for these pages. The process is so simple and free. For some business, they set a budget for building a fun base for their pages, so they use these pages to update and communicate with their followers.

**Video Conferencing:** A technology that allows users in different locations to hold face-to-face meetings without having to move to a single location. This technology is particularly convenient for business users in different cities or even different countries because it saves the time, expense and hassle associated with business travel.

**Use of digital networks** – ‘Phones and printers are all digitized, not like before when communication was hindered by telephone lines. During bad weather, most the lines would go off. Now with satellite and broadband transmissions, you can communicate with any one at work or off work via their mobile phones

### **The Digital Revolution Has Changed Media Communications for The Better Discuss**

The digital revolution is here, far reaching and with enormous impact, it has no doubt changed media communications forever. However, the true potential and extent of these changes has yet to be felt as the technology is still in relative infancy.

The digital age no doubt possesses impressive prospects, yet the changes it has made to date can be argued to be a mixed blessing to both media communications and to society as a whole. Loosely expressed, the digital revolution is the switching over from the traditional analogue signal of old to the new digital signal which, although requires a new receiver, promises to deliver much. However, this does not just affect television; Radio has also gone partially digital. It has also given way to arguably the most influential piece of modern communication technology, the internet. Now we are faced with literally hundreds more television channels than ever.

The digital revolution is here, far reaching and with enormous impact, it has no doubt changed media communications forever. However, the true potential and extent of these changes has yet to be felt as the technology is still in relative infancy. The digital age no doubt possesses impressive prospects, yet the changes it has made to date can be argued to be a mixed blessing to both media communications and to society as a whole. Loosely expressed, the digital revolution is the switching over from the traditional analogue signal

of old to the new digital signal which, although requires a new receiver, promises to deliver much.

This revolutionary is basically the process of socialization as the main line. Each appeared a kind of new media, the information communication process can have a qualitative leap and delivering content will also enrich and develop.

## CONCLUSION

The more advanced medium is, the richer amount of information it can carry. And then the communicating way changes. The way of thinking changes, too. The transformation of the media will inevitably affect the effect of education, especially the efficiency of teaching. Medium revolutionary will also affect the teaching strategies in the process of selection. Multiple, networked media can provide advanced teaching platform and rich teaching resources for the teaching. It can provide the technical support for learners and teachers to adopt more initiative learning style and teaching strategy. Educators will be more conducive to advanced education concept applied to teaching practice. It greatly promotes the development of the education reform, too.

**Technology is a drug.**

**We can't get enough of it.**

All these changes in media and communication that have taken place over the last century are due to a huge technological development. Furthermore, this is a cultural and technological evolution and it is the nature of evolution that it accelerates.

## REFERENCES

- [1] <http://www.tandfonline.com/doi/abs/10.1080/08838159809364463>
- [2] [http://www.caluniv.ac.in/global-mdia-journal/ARTICLE-JUNE-2014/A\\_3.pdf](http://www.caluniv.ac.in/global-mdia-journal/ARTICLE-JUNE-2014/A_3.pdf)
- [3] <http://www.ponline.org/node/367799>
- [4] [https://scholar.google.co.in/scholar?q=abstract+on+telecommunication,+technology+and+media+revolution&hl=en&as\\_sdt=0&as\\_vis=1&oi=scholart&sa=X&ved=0ahUKEWjAYKLtSsfSAhVFvY8KHbdcCS0QgQMIFzAA](https://scholar.google.co.in/scholar?q=abstract+on+telecommunication,+technology+and+media+revolution&hl=en&as_sdt=0&as_vis=1&oi=scholart&sa=X&ved=0ahUKEWjAYKLtSsfSAhVFvY8KHbdcCS0QgQMIFzAA)
- [5] <http://science.sciencemag.org/content/332/6025/60>
- [6] <http://www.bloomsbury.com/us/revolutions-in-communication-9781441114600/>
- [7] <http://www.forskningsradet.no/servlet/Satellite?blobcol=urldata&blobheader=application%2Fpdf&blobheadername1=Content-Disposition&blobheadervalue1=+attachment%3B+filename%3D%22ICTReportFinalweb.pdf%22&blobkey=id&blobtable=MungoBlobs&blobwhere=1274505119810&ssbinary=true>
- [8] <http://www.environmentalhistory.org/revcomm/readings-2/introduction/media-technology/>
- [9] <http://www.businessdictionary.com/definition/information-revolution.html>
- [10] <https://mobileafricarevisited.files.wordpress.com/2009/05/the-information-and-communication-technology-revolution.pdf>
- [11] [https://shiftingschool.files.wordpress.com/2011/04/understanding\\_mediarevolutio](https://shiftingschool.files.wordpress.com/2011/04/understanding_mediarevolutio)
- [12] <https://www.forbes.com/sites/gregsatell/2014/04/05/why-the-digital-revolution-is-really-just-getting-started/#551531993a72>
- [13] <https://books.google.co.in/books?hl=en&lr=&id=eUEKB-CMkIkC&oi=fnd&pg=PA1&dq=change+in++telecommunication,+technology+and+media+revolution&ots=W4zry>

- if-3z&sig=DwUem7Fz3xoI-a1YF1QWg51iGVk#v=onepage&q=change%20in%20%20telecommunication%2C%20technology%20and%20media%20revolution&f=false
- [14] <http://www.useoftechnology.com/technology-communication/>
- [15] <https://www.marsh.com/us/industries/communications-media-technology.html> Video Conferencing <http://www.investopedia.com/terms/v/video-conferencing.asp#ixzz4arCbfPe5>
- [16] [http://file.scirp.org/pdf/JSS\\_2015082110173146.pdf](http://file.scirp.org/pdf/JSS_2015082110173146.pdf)
- [17] <https://sites.google.com/a/york.ac.uk/media-communication-essay/8-conclusion>
- [18] <http://www.preservearticles.com/201107058875/essay-on-the-communication-revolution-blessing-or-burden.html>





**SECTION 3**

**Technology and Innovations for  
Next Generation**



# Body Mobile Changer

SHAMMI KUMAR<sup>1</sup> AND JYOTSNA PANDIT<sup>1</sup>

## INTRODUCTION

The present invention is particularly directed to an improved thermal or solar energy storage system employing a supercool-able medium for storage of thermal as well as solar energy.

Solar cell efficiencies could increase by 30 percent or more with new hybrid materials that make use of the infrared portion of the solar spectrum, researchers say.

Visible light accounts for under half of the solar energy that reaches Earth's surface. Nearly all of the rest comes from infrared radiation. However, solar infrared rays normally passes right through the photovoltaic materials that make up today's solar cells.

Now scientists at the University of California, Riverside, have created hybrid materials that can make use of solar infrared rays. The energy from every two infrared rays they capture is combined or "up converted" into a higher-energy photon that is readily absorbed by photovoltaic cells, generating electricity from light that would normally be wasted.

The hybrid materials are combinations of inorganic semiconductor nano-crystals, which capture the infrared photons, and organic molecules, which help combine the energy from these photons together into an up converted photon. In experiments, lead selenide nano-crystal captured near-infrared photons, and the organic compound rubrene emitted visible yellow- orange photons.

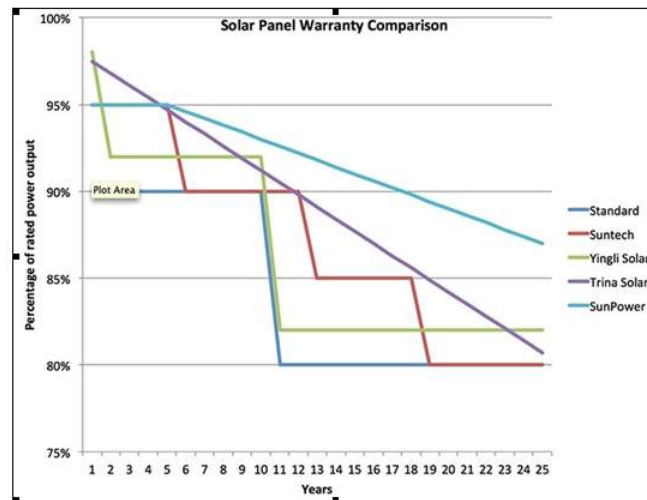

<sup>1</sup> Mangalmay Institute of Engineering & Technology, Gr. Noida (UP)  
E-mail: shammikarlupia7@gmail.com, jyotsnapandit4@gmail.com.

The researchers noted that lead selenide nanocrystal and rubrene were relatively inefficient at up conversion. However, in experiments with a hybrid material made of cadmium selenide nanocrystal and the organic compound di-phenylanthracene, which absorbs green light and emits violet light, the investigators could boost up conversion up to a thousand fold by coating the nanocrystal with anthracene, a component of coal tar. This suggests that similar coatings on lead selenide nanocrystal might boost their up conversion efficiency as well.

The scientists added that the ability to up convert two low energy photons into one, high- energy photon has potential applications in biological imaging, high-density data storage, and organic light-emitting diodes (OLEDs).

The silicon solar cells that currently dominate the world market suffer from three fundamental limitations. A promising new way of making high-efficiency solar cells, using perovskites instead of silicon, could address all three at once and supercharge the production of electricity from sunlight.

The first major limitation of silicon photovoltaic (PV) cells is that they are made from a material that is rarely found in nature in the pure, elemental form needed. While there is no shortage of silicon in the form of silicon dioxide (beach sand), it takes tremendous amounts of energy to get rid of the oxygen attached to it. Typically, manufacturers melt silicon dioxide at 1500–2000 degrees Celsius in an electrode arc furnace. The energy needed to run such furnaces sets a fundamental lower limit on the production cost of silicon PV cells and also adds to the emissions of greenhouse gases from their manufacture maintenance costs, especially for large-scale installations Thermoelectric power generation from waste heat is attracting more and more attention. Potential fuel efficiency enhancement by recovering the waste heat is beneficial for automobiles and many other applications. In addition, solar thermoelectric generator provides an alternative route to convert solar energy into electrical power besides the photovoltaic conversion . Thermoelectric generator (TEG) can be regarded as a heat engine using electrons/holes as the energy carrier. The conversion efficiency of a TEG is related to the Carnot efficiency and the material's average thermoelectric figure of merit  $ZT$ .

Approximately 90 percent of the world's electricity is generated by heat energy. Unfortunately, electricity generation systems operate at around 30 to 40 percent efficiency, meaning around two thirds of the energy input is lost as waste heat. Despite this, the inefficiency of current thermoelectric materials that can convert waste heat to electricity has meant their commercial use has been limited. Now researchers have developed a thermoelectric material they claim is the best in the world at converting waste heat into electricity, potentially providing a practical way to capture some of the energy that is currently lost.

The new material, which is based on the common semiconductor telluride, is environmentally stable and is expected to convert from 15 to 20 percent of waste heat to electricity. The research team, made up of chemists, material scientists and mechanical engineers from Northwestern University and Michigan State University, say the material exhibits a thermoelectric figure of merit (or "ZT") of, which they claim is the highest reported to date.

$$\eta = \left( \frac{T_H - T_C}{T_{II}} \right) \cdot \frac{\sqrt{1 + ZT_{avg}} - 1}{\sqrt{1 + ZT_{avg}} + (T_C / T_H)}$$

**PV System Efficiency**

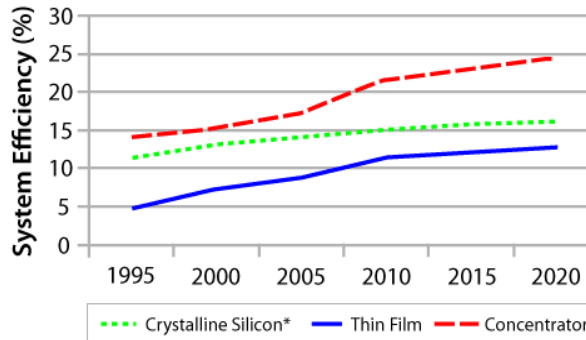

The higher a material’s ZT, the more efficient it is at converting heat to electricity. While there’s no theoretical upper limit to ZT, no known materials exhibit a ZT higher than 3. The researchers believe with a ZT of 2.2, the new material is efficient enough to be used in practical applications and could usher in more widespread adoption of thermo electrics by industry.

“Our system is the top-performing thermoelectric system at any temperature,” said Mercuri G. Kanatzidis, who led the research. “The material can convert heat to electricity at the highest possible efficiency. At this level, there are realistic prospects for recovering high- temperature waste heat and turning it into useful energy.”

With the huge potential for thermo electrics to recover some of the heat energy that is currently lost, they have been the focus of much research that has seen them improve significantly in recent years. So much so that the Mars rover Curiosity features lead tellurid thermo electrics, although its system only has a ZT of BMW is also testing systems to harvest the heat from the exhaust systems and combustion engines of its cars.

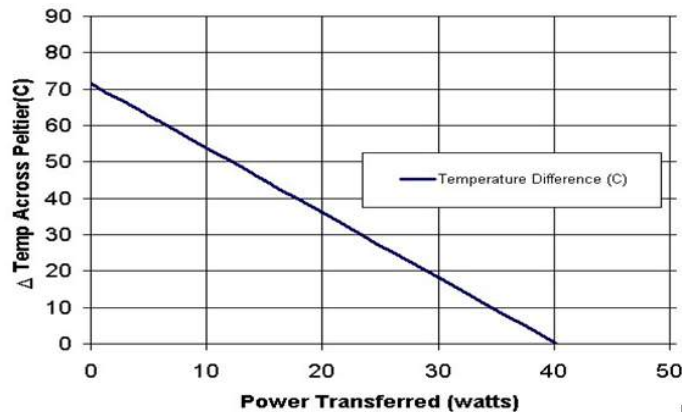

Aside from capturing some of the wasted heat energy emitted through a vehicle's tailpipe, the new material could be used in heavy manufacturing industries, including glass and brick making, refineries, and coal- and gas-fired power plants, and on large ships and tankers, where large combustion engines operate continuously. Such applications are seen as ideal as the waste heat temperatures in these areas can range from 400 to 600 degrees Celsius (750 to 1,100 degrees Fahrenheit), which is the sweet spot for thermoelectrics use.

	Monocrystalline Panels	Polycrystalline Panels	Thin Film Panels
Type			
Efficiency	14% - 18% cell efficiency	12% - 14% cell efficiency	5% - 6% cell efficiency
Temperature Tolerance	0% +5%	-5% +5%	-3% +3%
Life Time	25-30 year life span	20-25 year life span	15-20 year life span
Durability	Hail resistant 25 year P & M	25 year P & M warranty	25 year P & M warranty

where  $ZT = (S^2\sigma/\kappa)T$ , and  $S$ ,  $\sigma$ ,  $\kappa$ , and  $T$  are Seebeck coefficient, electrical conductivity, thermal conductivity, and absolute temperature, respectively. Pursuing high  $ZT$  has been the focus of the entire thermoelectric community by applying various phonon engineering via nano structuring approaches to reduce the thermal conductivity, or by exploring new compounds with intrinsically low thermal conductivity, such as compounds having complex crystalline structure, local rattlers, liquid-like sublattice, and highly distorted lattice. However, for practical applications, efficiency is not the only concern, and high output power density is as important as efficiency when the capacity of the heat source is huge (such as solar heat), or the cost of the heat source is not a big factor (such as waste heat from automobiles, steel industry, etc.). The output power density  $\omega$  is defined as the output power  $W$  divided by the cross-sectional area  $A$  of the leg, i.e.,  $\omega = W/A$ , which is related to power factor  $PF = S^2\sigma$  by the following:

### Seebeck coefficient

$$I = 0 \Rightarrow f_1[E_C(0) + \Delta_n] = f_2[E_C(0) + \Delta_n] \quad E_{F2} = E_{F1} - q\delta V$$

$$\frac{1}{1 + e^{\frac{E_C + \Delta_n - E_{F1}}{k_B T_{L1}}}} = \frac{1}{1 + e^{\frac{E_C + \Delta_n - E_{F1} + q\delta V}{k_B T_{L2}}}}$$

$$\frac{(E_C + \Delta_n - E_{F1})}{k_B T_{L1}} = \frac{(E_C + \Delta_n - E_{F1} + q\delta V)}{k_B T_{L2}}$$

$$\delta V = \frac{E_C(0) + \Delta_n - E_{F1}}{q T_{L1}} \delta T_L = -S_n \delta T_L$$

$$\delta V = -S_n \delta T_L$$

$$S_n = -\frac{[E_C(0) + \Delta_n - E_{F1}]}{q T_{L1}}$$

$$S_n = -\frac{[E_J - E_{F1}]}{q T_{L1}}$$

(by convention, S is negative for n-type semiconductors.)

contains two main parts: square of the temperature difference divided by leg length, and material power factor  $PF = S^2\sigma$ . Clearly, to achieve higher power density for a given heat source, we have to either increase the power factor PF or decrease the leg length. However, decreasing the leg length could cause severe consequences such as increase of large heat flux that will increase the cost of the heat management at the cold end, increase of percentage of contact resistance in the device that will increase the parasitic loss and consequently decrease the energy conversion efficiency, increase of the thermal stress due to the larger thermal gradient leading to device failure, etc. Therefore, it is better to increase the power factor PF. Because PF is a pure material parameter, we can use it as a criterion in searching for new thermoelectric materials for high output power.

A useful thermoelectric material should possess high ZT value for high efficiency, and also very importantly high PF for high output power. Ideally, temperature-independent ZT and PF over the whole temperature range from cold side to hot side are desired. However, both the

ZT and PF of all materials show strong temperature dependency, usually increasing first with temperature and then decreasing when bipolar effect starts to play a role. The working temperature of thermoelectric materials is limited by the band energy gap  $E_g$ ; e.g., Bi<sub>2</sub>Te<sub>3</sub>, a well-known thermoelectric material for applications below 200 °C, has an  $E_g$  of 0.13 eV. PbTe and associated materials have much higher peak ZT in the temperature range of

400–600 °C due to its larger  $E_g$  of 0.32 eV. However, the toxicity of lead, poor mechanical properties, and thermal instability above 400 °C seriously limit the application of Pb-based thermoelectric materials. Even though Mg<sub>2</sub>Si, skutterudites, and half-Heuslers are promising for thermoelectric power generation at up to 500 °C [Mg<sub>2</sub>Si and skutterudites



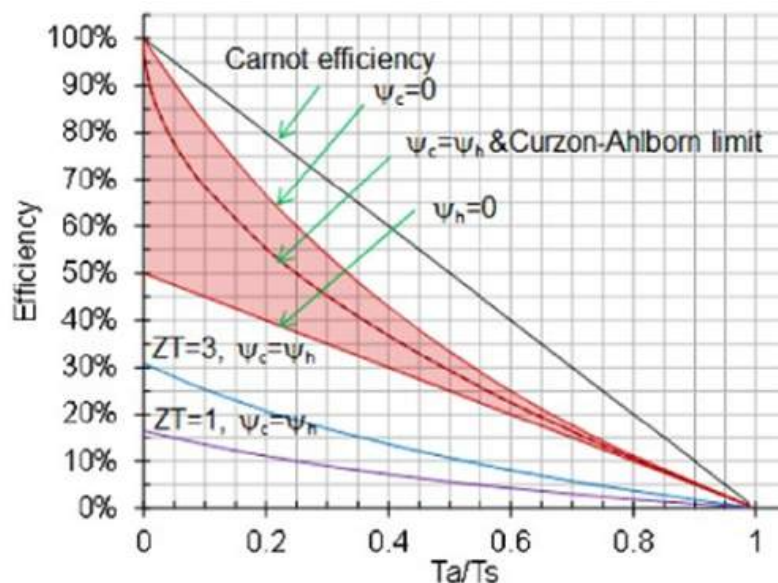

or 600–700 °C , the ZT values of these materials below 400°C is relatively low ( $ZT < 1$ ).

Other materials, such as n-type  $\text{In}_4\text{Se}_3\text{-}\delta$ , n-type  $\text{Ba}_8\text{Ga}_6\text{Sn}_3$  , and p-type  $\text{Zn}_{4-\delta}\text{Sb}_3$  have higher average ZT values below 400°C. However, the low power factors make them unsuitable for power generation applications below 400 °C. Because both efficiency and output power are equally important, new n- and p-type materials that can work up to 400 °C are more desirable for thermoelectric power generation.

Here, we report a new  $\text{Mg}_2\text{Sn}$ -based n-type thermoelectric material that shows promise to work below 400 °C for power generation due to the narrow band gap of  $\approx 0.26$  eV. Historically,  $\text{Mg}_2\text{Sn}$  material has been investigated less than its analogous compound  $\text{Mg}_2\text{Si}$  for thermoelectric applications due to its lower ZT. Most of the research has been focused on the alloy of  $\text{Mg}_2\text{Si}$ - $\text{Mg}_2\text{Sn}$  with a peak ZT value of  $\approx 1$  at 500°C. Recently, different groups have improved the peak ZT value to 1.1–1.3 by adjusting the x value in the  $\text{Mg}_2\text{Si}_{1-x}\text{Sn}_x$  solid solution. The challenges in preparing and handling these materials were the high vapor pressure and chemical activity of Mg. Methods of direct comelting with subsequent annealing, and solid-state reaction with subsequent annealing and Bridgman method were reported to synthesize  $\text{Mg}_2\text{Si}$ - $\text{Mg}_2\text{Sn}$  alloys . Powder metallurgy route, e.g., ball milling plus hot pressing, was widely used to fabricate a variety of high-performance thermoelectric bulk materials such as  $\text{Bi}_2\text{Te}_3$ ,  $\text{PbTe}$  ,  $\text{PbSe}$  , and skutterudites  $\text{CoSb}_3$ . In fact, ball milling was reported to synthesize  $\text{Mg}_2\text{Si}$  and its alloys  $\text{Mg}_2\text{Si}$ - $\text{Mg}_2\text{Sn}$  . However, the reported ZT was lower than 0.7, which may be due to the difficulty in avoiding oxidization of Mg. Here, we report a successful synthesis of an Sn-dominated composition  $\text{Mg}_2\text{Sn}_{0.75}\text{Ge}_{0.25}$  through ball milling and hot pressing to achieve a ZT of 1.4 at 450 °C and power factor PF of  $55 \mu\text{W}\cdot\text{cm}^{-1}\cdot\text{K}^{-2}$  at 350 °C. Calculations show that these could yield a leg efficiency  $\eta$  of 10.5%, and output power density  $\omega$  of 6.6

$W \cdot \text{cm}^{-2}$  at  $T_h = 400^\circ\text{C}$  and  $T_c = 50^\circ\text{C}$ , which will be very useful for the vast amount of waste heat sources at up to  $400^\circ\text{C}$  and concentrated solar energy conversion applications.

### **SELF CLEANING**

Solar panels would be especially effective in large installations. The desert environments where many of these installations reside often challenge the panels with dust storms and little rain. Currently, only about 4 percent of the world's deserts are used in solar power harvesting. Conventional methods of cleaning solar panels usually involve large amounts of water which is costly and scarce in such dry areas.

### **SELF CLEANING TECHNIQUE**

The self-cleaning technology was developed by Boston University professor Malay K. Mazumder and his colleagues, in association with the National Aeronautics and Space Association, and was originally intended for use in rovers and other machines sent to space missions to the moon and to Mars.

The technology involves the deposition of a transparent, electrically sensitive material on glass or on a transparent plastic sheet that cover the panels. Sensors monitor dust levels on the surface of the panel and energize the material when dust concentration reaches a critical level.

The electric charge sends a dust-repelling wave cascading over the surface of the material, lifting away the dust and transporting it off of the screen's edges. Within two minutes, the process removes about 90 percent of dust on a solar panel. The mechanism reportedly requires only a small amount of the electricity generated by the panel for it to work.

Coating the surface of solar cells can increase their efficiency and reduce maintenance costs, especially for large-scale installations. Self cleaning solar panels would be especially effective in large installations. The desert environments where many of these installations reside often challenge the panels with dust storms and little rain. Currently, only about 4 percent of the world's deserts are used in solar power harvesting. Conventional methods of cleaning solar panels usually involve large amounts of water which is costly and scarce in such dry areas.

### **ROBOTIC VACUUM CLEANER**

This system is implemented using two subsystems namely a Robotic Vacuum Cleaner and a Docking Station.. The robot uses a two stage cleaning process to remove dust effectively from the solar panels. A rolling brush is placed in front to disperse the dust towards the vacuum cleaner. A high speed motor capable of creating suitable suction is used for removing dust from the panels. It traverses the solar panel using a pre-defined path controlled by the accelerometers and ultrasonic sensor. It is designed to work on inclined and slippery surfaces. A control strategy is formulated to navigate the robot in the required path using an appropriate feedback mechanism. The battery voltage of the robot is determined periodically and if it goes below ,it returns to the docking station and charges

itself automatically using power drawn from the solar panels. It is robust, commercially viable product which provides a simple, cost-effective solution to the clean small solar panels.

Motor fitted to solar panel and periodically a jerk can be given to panels, so dust slides down.

Nano work Spotlight) Graphene-based nano materials have many promising applications in energy-related areas. In particular, there are four major energy-related areas where graphene will have an impact: solar cells, super capacitors, lithium-ion batteries, and catalysis for fuel cells (“Graphene-based nanotechnology in energy applications”).

The extremely high electron mobility of graphene – under ideal conditions electrons move through it with roughly 100 times the mobility they have in silicon – combined with its superior strength and the fact that it is nearly transparent (2.3 % of light is absorbed; 97.7 % transmitted), make it an ideal candidate for photovoltaic applications. It could be a promising replacement material for indium tin oxide (ITO), the current standard material for transparent electrodes used for electrodes in LCD displays, solar cells, iPad and smart-phone touch screens, and organic light-emitting diode (OLED) displays for televisions and computer monitors.

Just yesterday, for instance, there was a report (“Nanotechnology researchers make major leap towards graphene for solar cells”) that shows that graphene retains its impressive set of properties when it is coated with a thin silicon film. These findings pave the way for entirely new possibilities to use in thin-film photovoltaics.

A new review in *Advanced Energy Materials* (“Graphene-Based Materials for Solar Cell Applications”) by a team of scientists from Nanyang Technological University, led by Prof. Hua Zhang, provides an overview of the recent research on graphene and its derivatives, with a particular focus on synthesis, properties, and applications in solar cells.

Current solar cells cannot convert all the incoming light into usable energy because some of the light can escape back out of the cell into the air. Additionally, sunlight comes in a variety of colors and the cell might be more efficient at converting bluish light while being less efficient at converting reddish light. Lower energy light passes through the cell unused. Higher energy light does excite electrons to the conduction band, but any energy beyond the band gap energy is lost as heat. If these excited electrons aren’t captured and redirected, they will spontaneously recombine with the created holes, and the energy will be lost as heat or light.

## **NANOTECHNOLOGY IMPROVES THE SOLAR CELL**

Present available nanotechnology solar cells are not as efficient as traditional ones, however their lower cost offsets this. In the long term nanotechnology versions should both be lower cost and, using quantum dots, should be able to reach higher efficiency levels than conventional ones.

To coat the nanoparticles with quantum dots tiny semiconductor crystals. Unlike conventional materials in which one photon generates just one electron, quantum dots have the potential to convert high-energy photons into multiple electrons. Quantum dots

work the same way, but they produce three electrons for every photon of sunlight that hits the dots. Electrons moves from the valance band into the conduction band The dots also catch more spectrums of the sunlight waves, thus increasing conversion efficiency to as high as 65 percent. Another area in which quantum dots could be used is by making so-called a hot carrier cells. Typically the extra energy supplied by a photon is lost as heat, but with a hot carrier cells the extra energy from the photons result in higher-energy electrons which in turn leads to a higher voltage .

The transport of electrons across the particle net-work is the major problem in achieving higher photo conversion efficiency in nanostructured electrode. Utilization of CNT network support to anchor light harvesting semiconductor particles by assisting the electron transport to the collecting electrode surface in DSSC. Charge injection from excited CdS into SWCNT excitation of CdS nanoparticle. When CNTS attached in Cdse & CdTe can induce charge transfer process under visible light irradiation. The enhanced interconnectivity between the titanium dioxide particles and the MWCNTs in the porous titanium dioxide film was concluded to be the cause of the improvement in short circuit current density. Nanotechnology might be able to increase the efficiency of solar cells, but the most promising application of nanotechnology is the reduction of manufacturing cost. Chemists at the University of California, Berkeley, have discovered a way to make cheap plastic solar cells that could be painted on almost any surface. These new plastic solar cells achieve efficiencies of only 1.7 percent; however, Paul Alivisatos, a professor of chemistry at UC Berkeley states, "This technology has the potential to do a lot better. There is a pretty clear path for us to take to make this perform much better" .

These new plastic solar cells utilize tiny nanorods dispersed within in a polymer. The nanorods behave as wires because when they absorb light of a specific wave-length they generate electrons. These electrons flow through the nanorods until they reach the aluminum electrode where they are combined to form a current and are used as electricity

GaAs (thin film) with Peltier' s tiles connected on the base of GaAs thin film for use of extra energy from sun. Hybrid solar have used 30% more efficient than normal PV cell. Heat energy Effects the PV cell and decrease efficiency of PV cell but heat on solar cell absorbed by the peltier connected in series with aluminium heat sink at colder side produced potential difference which increase the efficiency of solar panel and provides long age of panel. Results:-The results prove my hypothesis, that even with all the thermal and voltage conversion losses, increases the efficiency of hybrid solar panel.

Picture of a solar cell, which utilizes nanorods to convert light into electricity, is shown in fig.

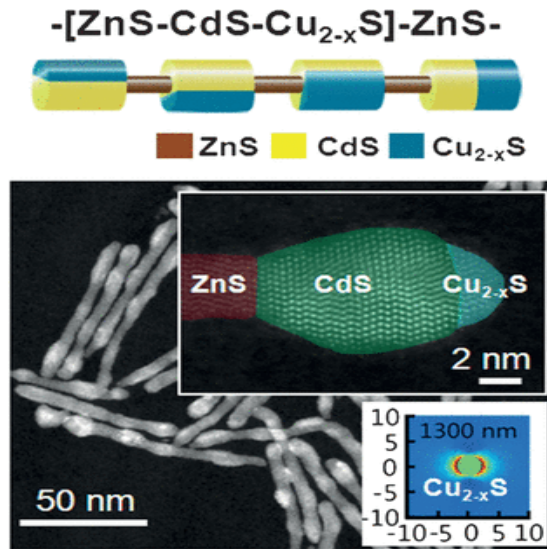

These new plastic solar cells utilize tiny nanorods dispersed within in a polymer. The nano-rods behave as wires because when they absorb light of a specific wave-length they generate electrons. These electrons flow through the nanorods until they reach the aluminum electrode where they are combined to form a current and are used as electricity

GaAs (thin film) with Peltier's tiles connected on the base of GaAs thin film for use of extra energy from sun. Hybrid solar have used 30% more efficient than normal PV cell. Heat energy Effects the PV cell and decrease efficiency of PV cell but heat on solar cell absorbed by the peltier connected in series with aluminium heat sink at colder side produced potential difference which increase the efficiency of solar panel and provides long age of panel.

**Results:-**The results prove my hypothesis, that even with all the thermal and voltage conversion losses, increases the efficiency of hybrid solar panel. Heat from sun 70-80% heat used which increase efficiency and life of solar cell.

## REFERENCES

- [1] The Semiconductor Physics: An Introduction, *Karlheinz Seeger*.
- [2] G. Jeffrey Snyder, "Thermoelectrics". <http://www.its.caltech.edu/~jsnyder/thermoelectrics>.
- [3] Nanosolar Ships First Panels from Nanosolar Blog <http://www.greentechmedia.com/articles/read/Nanosolar-Thin-Film-Solar-Hype-Firm-Officially-Dead>.
- [4] <http://www.siliconbeat.com/2013/07/15/the-growing-cigs-graveyard-nanosolar-liquidation-auction>.
- [5] <http://www.siliconbeat.com/2013/07/15/the-growing-cigs-graveyard-nanosolar-liquidation-auction>.
- [6] "<http://www.gizmag.com/lumen-flashlight/39893/>
- [7] "<http://www.gizmag.com/lumen-flashlight/39893/>
- [8] "<http://www.gizmag.com/lumen-flashlight/39893/>

- [9] Ulanoff, L. Elon Musk and SolarCity unveil ‘world’s most efficient’ solar panel, Mashable, October 2, 2015, accessed June 28, 2016.
- [10] Milestone in solar cell efficiency achieved: New record for unfocused sunlight edges closer to theoretic limits. Wilson da Silva. Science Daily. May 17, 2016.
- [11] University of New South Wales. “Milestone in solar cell efficiency achieved: New record for unfocused sunlight edges closer to theoretic limits.” ScienceDaily, 17 May 2016.
- [12] Li, Wei; Rubin, Tzameret H.; Onyina, Paul A. (2013-05-01). “Comparing Solar Water Heater Popularization Policies in China, Israel and Australia: The Roles of Governments in Adopting Green Innovations”. *Sustainable Development*. 21 (3): 160–170. doi:10.1002/sd.1547. ISSN 1099-1719.
- [13] Morgan Baziliana; et al. (17 May 2012). Re-considering the economics of photovoltaic power. UN-Energy (Report). United Nations. Retrieved 20 November 2012.
- [14] KING, R.R., et al., *Appl. Phys. Letters* 90 (2007) 183516.
- [15] “SunPower e20 Module”.
- [16] “HIT Photovoltaic Module” (PDF). Sanyo / Panasonic. Retrieved 25 November 2016.
- [17] Photovoltaic Solar Resource of the United States, [http://www.nrel.gov/gis/images/map\\_pv\\_national\\_lo-res.jpg](http://www.nrel.gov/gis/images/map_pv_national_lo-res.jpg).
- [18] *Seebeck Coefficient*, *Electronics Cooling.com* (accessed 2013-Feb-01).

# Seamless Mobility of IP Connectivity of Manet in Disaster Area

ANAND PRAKASH SRIVASTAVA<sup>1</sup> AND PAYAL KANSAL<sup>2</sup>

## Abstract

*Disaster situations are one of the most important commercial applications of Mobile Ad-hoc Network (MANET). These situations propose three requirements to the network: fast arrangement, automatic formation and internet connection. To fulfill the first and second requirement, the host in the MANET may obtain network configuration by auto configuration. When the MANET connects to the internet, Mobile IP is the first choice of management of mobility. But the assumptions made in Mobile IP conflicts with the requirement presented in disaster area. The first assumption is that each node has been assigned a static and unique Home address. The second is that the Home Agent has been arranged and maintained usable. This paper presents a new solution to mobility management in the MANET where dynamic DNS (DOMAIN NAME SERVER) update is used for mobile host location and Migrate is used for mobile handoff support. As a result, the nodes in disaster area can form a MANET automatically and move between different gateways without prerequisites.*

**Keyword:** MANET (Mobile Ad-Hoc Network), Auto Configuration, Mobile IP, Internet

## INTRODUCTION

Mobile Ad-Hoc Network (MANET) is a cluster of mobile, wireless nodes which cooperatively and spontaneously form a network. The MANET is an increasingly important topic in wireless communications. In the early years the research on MANET was mainly for military purpose. Recently the MANET is increasingly important in the commercial and residential areas. The situations where the MANET is suitable are analyzed in.

Disaster situations have been figured out as a typical usage scenario for the MANET. In the case of a disaster, the whole infrastructure may be destroyed. The environment will be unpredictable. Therefore, the network must be arranged as quickly as possible and should be survivable and also should be worked out efficiently. The MANET involves invaluable features that are desirable in these situations such as fast arrangement and dynamic topology support.

For the feature of fast arrangement, the mobile hosts in the configurations or network devices. They obtain network parameters such as a IP address by automatic configuration. The advantages of these configurations are fast and without human intervention.

---

<sup>1</sup> Assistant Professor, NITRA Technical Campus, Ghaziabad (UP)  
E-mail: anand.infotech@gmail.com

<sup>2</sup> Assistant Professor, SDEC, Ghaziabad (UP)  
E-mail: payalkansal@gmail.com

In the disaster area, there may be a several group of disaster workers with different tasks. Several vehicles may be arranged which can be connected to the internet. Each team needs internal coordination and external coordination as well. If possible, each disaster worker can access the internet through commands vehicles nearby. Command vehicles in the disaster area may function as a router on an external IP network and may provide other MANET hosts with access to the external network. Such a node is here after referred to as an Internet Gateway. Once a Mobile Host (MH) in the MANET connects the internet through a gateway, the addressing becomes hierarchical and the MH is capable of moving from one gateway to another. It becomes necessary that an additional mobility management mechanism be supported.

Mobile IP is an Internet Engineering Task Force (IETF) standard for host mobility. It provides transparent and

Mandatory mobility support to various applications in IP substrate. When MANET connects to the internet, Mobile IP is almost first choice for mobile management. But these solutions do not apply in the disaster area since there is a basic requirement for in Mobile IP each node is supposed to have been assigned an IP address statistically and unchangeably. All the solutions above are based on an assumption that the MH in the MANET has obtained a static home address which last forever. The IP address the MH obtained in the MANET is a Care-of-address (CoA) which changes from one gateway to another. Care Of Address is temporary IP address for mobile device. A separate address is required because the IP address of the device that is used as host identifications is topologically incorrect. It does not match the network of attachment. The Care Of Address splits the dual nature of an IP address that is its use is to identify the host and the location within the global IP network.

The prerequisites to form a MANET in the disaster area are difficult to fulfill and time consuming or even impossible when victims in the disaster area also have some devices to attend in the MANET. Hence for such unfavorable conditions the following new techniques are proposed.

In this paper new solution is presented to mobility management in the MANET where dynamic DNS (Domain Name Server) update is used for mobile host location and Migrate is used for mobile handoff support. As a result, nodes in disaster situations can form a MANET automatically and move between different gateways without prerequisites.

## **LITERATURE SURVEY**

### **Mobile IP**

**Mobile IP (or IP mobility)** is an Internet Engineering Task Force (IETF) standard communications protocol that is designed to allow mobile device user to move from one network to another while maintaining a permanent IP address. The foundation behind Mobile IP is the pair address scheme. A mobile node is assigned a home address that is static to unchangeable to serve as its unique endpoint identifier. It is also assigned a Care Of Address (CoA) which is the IP address to identify the mobile host current point of attachment. There are two mobile agents in Mobile IP, a Home Agent (HA) located at



the home network and a Foreign Agent (FA) located at the foreign network. The mobile agent's asset the mobility management function.

### **Migrate**

Migrate is an end-to-end approach to host mobility proposed by **Snoeren** and **Balakrishnan** in MIT in the year 2000. Migrate uses an FQDN (Fully Qualified Domain Name) as a host invariant name and dynamic updates to the DNS to track host location. Session maintenance is the most difficult problem in this approach. It requires an end-to-end participation between end hosts. A novel set of Migrate options in TCP SYN segment is used to negotiate a change in end point IP address. This TCP connection migration can be accomplished by exchanging two TCP segments: one SYN segment with migrate option, the other ACK of that segment. To prevent connection hijacking, the exchange can be secured using IPSec or an optional Diffie- Hellman key exchange at the connection endpoint.

### **Care-of-address**

A Care-of-address is a temporary IP address for a mobile device. This allows a home agent to forward messages to the mobile device. A separate address is required because the IP address of the device that is used as host identification is topologically incorrect- it does not match the network of attachment. The care-of-address splits the dual nature of an IP address, that is, its use is to identify the host and location within the global IP network. The care-of-address has to be a valid IP address within the foreign network, so that it allows the mobile node to receive and make connections with any host in the outside.

## **PROPOSED ARCHITECTURE**

According to the operation of Mobile IP, the following steps will be happened when the node NB in WLAN1 communicates with the node NA which has been moved into the disaster area MANET1:

- When the mobile host NA moves into MANET1, it will obtain a topologically correct IP address IP\_CoA.
- The mobile host NA initializes a registration process to inform it's HA (Home Agent) in WLAN1 of the new CoA.
- The mobile host NB sends a packet to the mobile host NA's home address IP\_HoA in WLAN1.
- This packet is intercepted by HA in WLAN1, and redirected to the mobile host NA's Care Of Address IP\_CoA.
- Safely come to the conclusion: (1) A global unique home address has been assigned; and
- (2) The corresponding home agent has been deployed.
- These two conditions must be fulfilled before a mobile host joins in the MANET disaster area.
- Due to the connectivity between wired IP networks and Ad-Hoc network, Ad-Hoc network

are integrated into the global connectivity provided by the internet. Our solution assumes that each host has an FQDN as an invariant identity. The following steps outline the operation of our solution.

- The mobile host NA moves from WLAN1 into MANET1.
- The Internet Gateway in MANET1 (CM1) broadcast agent advertisement messages periodically.
- The mobile host NA changes the network prefix of its IP address according to the agent advertisement it has received. This new IP address is topologically correct in MANET1.
- The mobile host NA initializes a dynamic DNS update to inform its DNS server (dns2) on the home network of the IP address of its current gateway.
- When the mobile host NB wants to communicate with the mobile host NA, NB sends a DNS request to dns2 asking for the IP address according to the name of NA.
- The server dns2 redirects this request to the gateway CM1 in MANET1.
- The gateway CM1 broadcast the name request packet in MANET1 asking for the IP address of the mobile host NA.
- NA replies its current IP address to CM1. CM1 replies this address to dns2. And then dns2 returns this address to the mobile host NB.
- NB sends packets directly to NA's current IP address in MANET1.
- The mobile host NA moves from MANET1 into MANET2 and obtains a topologically correct IP address again.
- NA initializes a dynamic DNS update to inform dns2 the IP address of its current gateway CM2.
- NA starts a connection migration by sending out a SYN segment with migrate option to NB.
- When NB sends back ACK of that segment, the TCP connection between NA and NB resumes again.

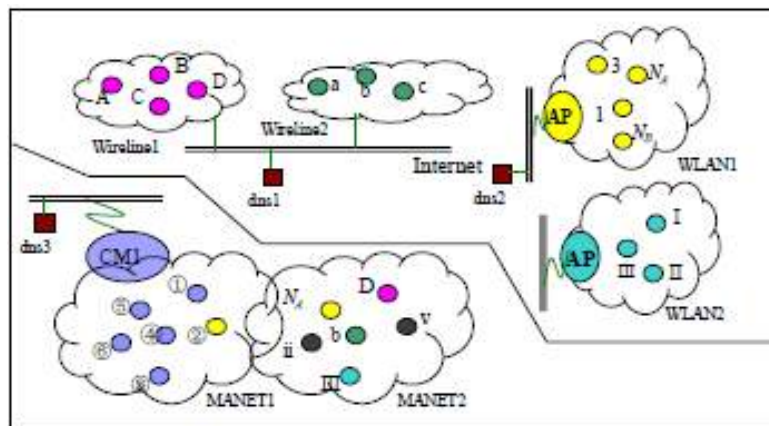

**Figure 1:** A MIP&MANET Sample Emergency Scenario

## **CONCLUSION**

In this paper dynamic DNS (Domain Name Server) update is used to track the user's location when the MANET connected to the internet. A DNS server is any computer registered to join the Domain Name System. A DNS server runs special purpose networking software, features a public IP address and contains a database of network names and addresses for other internet hosts. This approach for mobility management is more appropriate than mobile IP, because the nodes in the MANET obtain IP addresses by auto-configuration. However in this paper only simple domain model is taken into consideration. Namely the DNS server is on the same host as the gateway. But the concept of the domain in the DNS is a logical one.

## **REFERENCES**

- [1] M. Leiner, D.L. Neilson, F.A. Topagi, Special issue on packet radio networks, Proceedings of the IEEE, vol. 75, no. 1, Jan. 1987
- [2] K. Daniel Wong, T.J. Kwon, V. Varma, "Towards Commercialization of Ad-Hoc Network", Proceedings of the 2004 IEEE International Conference on Networking, Sensing & Control, Taipei, Taiwan, March 21-23, 2004.
- [3] C. E. Perkins, E. M. Royer, and S. R. Das: IP Address Auto-Configuration for Ad-Hoc Network, Technical Report Draft-ietf-manet-autoconf-00.txt, July 2000.
- [4] Sanket Nesargi and Ravi Prakash: MANET conf: Configuration of host in mobile Ad-Hoc Network, Proceedings of INFOCOM2002.
- [5] Jung-Soo Park, Yong-Jin Kim, and Sung-Woo Park, "Stateless Address Auto-Configuration in mobile Ad-Hoc Network Using Site-Local Address", 2001, Internet Draft: draft-park-zeroconf-manet-ipv6-00.txt.
- [6] K. Weniger and M. Zitterbart, "IPv6 Stateless Address Auto-Configuration in large mobile Ad-Hoc Network", Proc. EurWireless 2002

# Anatomy of Android Application

ANAND PRAKASH SRIVASTAVA<sup>1</sup>, PAYAL KANSAL<sup>2</sup> AND SUSHIL K MAURYA<sup>3</sup>

## ABSTRACT

*The increasing popularity of Google's mobile platform Android makes it the prime target of the latest surge in mobile malware. Most research on enhancing the platform's security and privacy controls requires extensive modification to the operating system, which has significant usability issues and hinders efforts for widespread adoption. We develop a novel solution called Aurasium that bypasses the need to modify the Android OS while providing much of the security and privacy that user's desire. We automatically repackage arbitrary applications to attach user-level sandboxing and policy enforcement code, which closely watches the application's behaviour for security and privacy violations such as attempts to retrieve a user's sensitive information, send SMS covertly to premium numbers, or access malicious IP addresses.*

## INTRODUCTION

Android is a Linux-based operating system designed primarily for touch screen mobile devices such as smart phones and tablet computers. Initially developed by Android, Inc., which Google backed financially and later purchased in 2005, Android was unveiled in 2007 along with the founding of the Open Handset Alliance: a consortium of hardware, software, and telecommunication companies devoted to advancing open standards for mobile devices. The first Android-powered phone was sold in October 2008.

Android has a large community of developers writing applications (“apps”) that extend the functionality of devices, written primarily in a customized version of the Java programming language.

Android's open nature has further encouraged a large community of developers and enthusiasts to use the open source code as a foundation for community-driven projects, which add new features for advanced users or bring Android to devices which were officially released running other operating systems.

Android had a worldwide Smartphone market share of 75% during the third quarter of 2012, with 500 million devices activated in total and 1.3 million activations per day. The operating system's success has made it a target for patent litigation as part of the so-called “Smartphone wars” between technology companies.

---

<sup>1</sup> Assistant Professor, NITRA Technical Campus, Ghaziabad (UP)  
E-mail: anand.infotech@gmail.com

<sup>2</sup> Assistant Professor, SDEC, Ghaziabad (UP)  
E-mail: payalkansal@gmail.com

<sup>3</sup> Associate Professor, NMANTEC, Ghaziabad (UP)  
E-mail: swatityagi24@gmail.com

## **HISTORY**

Android, Inc. was founded in Palo Alto, California in October 2003 by Andy Rubin (co-founder of Danger), Rich Miner (co-founder of Wildfire Communications, Inc.), Nick Sears (once VP at T-Mobile), and Chris White (headed design and interface development at WebTV) to develop, in Rubin's words "smarter mobile devices that are more aware of its owner's location and preferences"., Inc. was founded in Palo Alto, California in October 2003 by Andy Rubin (co-founder of Danger Android), Rich Miner (co-founder of Wildfire Communications, Inc.), Nick Sears (once VP at T-Mobile), and Chris White (headed design and interface development at WebTV) to develop, in Rubin's words "smarter mobile devices that are more aware of its owner's location and preferences

Google acquired Android Inc. on August 17, 2005, making it a wholly owned subsidiary of Google. Key employees of Android Inc., including Rubin, Miner and White, stayed at the company after the acquisition.

Speculation about Google's intention to enter the mobile communications market continued to build through December 2006. On November 5, 2007, the Open Handset Alliance, a consortium of technology companies including Google, device manufacturers such as HTC and Samsung, wireless carriers such as Sprint Nextel and T-Mobile, and chipset makers such as Qualcomm and Texas Instruments, unveiled itself, with a goal to develop open standards for mobile devices. That day, Android was unveiled as its first product, a mobile device platform built on the Linux kernel version 2.6. The first commercially available phone to run Android was the HTC Dream, released on October 22, 2008, Since 2008, Android has seen numerous updates which have incrementally improved the operating system, adding new features and fixing bugs in previous releases. Each major release is named in alphabetical order after a dessert or sugary treat; for example, version 1.5 Cupcake was followed by 1.6 Donut. The latest release is 4.2 Jelly Bean. In 2010, Google launched its Nexus series of devices—a line of smartphones and tablets running the Android operating system, and built by a manufacturer partner. HTC collaborated with Google to release the first Nexus smartphone, the Nexus One. The series has since been updated with newer devices, such as the Nexus 4 phone and Nexus 10 tablet, made by LG and Samsung, respectively. Google releases the Nexus phones and tablets to act as their flagship Android devices, demonstrating Android's latest software and hardware features.

## **FEATURES IN ANDROID**

### **Handset Layouts**

The platform is adaptable to larger, VGA, 2D graphics library, 3D graphics library based on OpenGL ES 2.0 specifications, and traditional Smartphone layouts.

### Storage

SQLite, a lightweight relational database, is used for data storage purposes.

### Connectivity

Android supports connectivity technologies including GSM/EDGE, IDEN, CDMA, EV-DO, UMTS, Bluetooth, Wi-Fi, LTE, NFC and WiMAX.



### Messaging

SMS and MMS are available forms of messaging, including threaded text messaging and Android Cloud To Device Messaging (C2DM) and now enhanced version of C2DM, Android Google Cloud Messaging (GCM) is also a part of Android Push Messaging service.

### Multiple Language Support

Android supports multiple languages.

### Web Browser

The web browser available in Android is based on the open-source WebKit layout engine, coupled with Chrome's V8 JavaScript engine. The browser scores 100/100 on the Acid3 test on Android 4.0.

### Java Support

While most Android applications are written in Java, there is no Java Virtual Machine in the platform and Java byte code is not executed. Java classes are compiled into Dalvik executables and run on Dalvik, a specialized virtual machine designed specifically for Android and optimized for battery-powered mobile devices with limited memory and CPU

### Media Support

Android supports the following audio/video/still media formats: WebM, H.263, H.264, AAC, HE-AAC (in 3GP or MP4 container), MPEG 4 SP, AMR, AMR-WB (in 3GP container), MP3, MIDI, Ogg Vorbis, FLAC, WAV, JPEG, PNG, GIF, BMP, WebP.

### Additional Hardware Support

Android can use video still camera as, touchscreens, GPS, accelerometers, gyroscopes, barometers, magnetometers, dedicated gaming controls, proximity and pressure sensors, thermometers, accelerated 2D bit blits (with hardware orientation, scaling, pixel format conversion) and accelerated 3D graphics.

**Multi-touch**

Android has native support for multi-touch which was initially made available in handsets such as the HTC Hero. The feature was originally disabled at the kernel level (possibly to avoid infringing Apple's patents on touch-screen technology at the time). Google has since released an update for the Nexus One and the Motorola Droid which enables multi-touch natively.

**Bluetooth**

Supports A2DP, AVRCP, sending files (OPP), accessing the phone book (PBAP), voice dialing and sending contacts between phones. Keyboard, mouse and joystick (HID) support is available in Android 3.1+, and in earlier versions through manufacturer customizations and third-party applications.

**Video Calling**

Android does not support native video calling, but some handsets have a customized version of the operating system that supports it, either via the UMTS network (like the Samsung Galaxy S) or over IP. Video calling through Google Talk is available in Android 2.3.4 and later. Gingerbread allows Nexus S to place Internet calls with a SIP account. This allows for enhanced VoIP dialing to other SIP accounts and even phone numbers. Skype 2.1 offers video calling in Android 2.3, including front camera support. Users with the Google+ android app can video chat with other google+ users through hangouts.

**Multitasking**

Multitasking of applications, with unique handling of memory allocation, is available.

**Accessibility**

Built in text to speech is provided by Talk back for people with low or no vision. Enhancements for people with hearing disabilities is available as is other aids.

**Voice Based Features**

Google search through voice has been available since initial release. Voice actions for calling, texting, navigation, etc. are supported on Android 2.2 onwards. As of Android 4.1, Google has expanded Voice Actions with the ability to talk back and read answers from Google's Knowledge Graph when queried with specific commands. The ability to control hardware has not yet been implemented.

**Tethering**

Android supports tethering, which allows a phone to be used as a wireless/wired Wi-Fi hotspot. Before Android 2.2 this was supported by third-party applications or manufacturer customizations.

## Screen Capture

Android supports capturing a screenshot by pressing the power and volume-down buttons at the same time. Prior to Android 4.0, the only methods of capturing a screenshot were through manufacturer and third-party customizations or otherwise by using a PC connection (DDMS developer's tool). These alternative methods are still available with the latest Android.

## External Storage

Most Android devices include microSD slot and can read microSD cards formatted with FAT32, Ext3 or Ext4 file system. To allow use of high-capacity storage media such as USB flash drives and USB HDDs, many Android tablets also include USB 'A' receptacle. Storage formatted with FAT32 is handled by Linux Kernel VFAT driver, while 3rd party solutions are required to handle other popular file systems such as NTFS, HFS Plus and exFAT.

## BROADCAST INTENT RECEIVER

You can use a Broadcast Receiver when you want code in your application to execute in reaction to an external event, for example, when the phone rings, or when the data network is available, or when it's midnight. Broadcast Receivers do not display a UI, although they may use the Notification Manager to alert the user if something interesting has happened. Broadcast Receivers are registered in AndroidManifest.xml, but you can also register them from code using `Context.registerReceiver ()`. Your application does not have to be running for its BroadcastReceivers to be called; the system will start your application, if necessary, when a BroadcastReceiver is triggered. Applications can also send their own intent broadcasts to others with `Context.sendBroadcast ()`.

## Building Blocks to an Android Application

There are four building blocks to an Android application:

- Activity
- Broadcast Intent Receiver
- Service
- Content Provider

## ACTIVITY

Activities are the most common of the four Android building blocks. An activity is usually a single screen in your application. Each activity is implemented as a single class that extends the Activity base class. Your class will display a user interface composed of Views and respond to events. Most applications consist of multiple screens. For example, a text messaging application might have one screen that shows a list of contacts to send messages to, a second screen to write the message to the chosen contact, and other screens to review old messages or change settings. Each of these screens would be implemented as



an activity. Moving to another screen is accomplished by a starting a new activity. In some cases and activity may return a value to the previous activity -- for example an activity that lets the user pick a photo would return the chosen photo to the caller.

### **Intent and Intent Filters**

Android uses a special class called Intent to move from screen to screen. Intent describes what an application wants done. The two most important parts of the intent data structure are the action and the data to act upon. Typical values for action are MAIN (the front door of the application), VIEW, PICK, EDIT, etc. The data is expressed as a URI. For example, to view contact information for a person, you would create intent with the VIEW action and the data set to a URI representing that person.

There is a related class called an Intent Filter. While an intent is effectively a request to do something, an intent filter is a description of what intents an activity (or Broadcast Receiver, see below) is capable of handling. An activity that is able to display contact information for a person would publish an Intent Filter that said that it knows how to handle the action VIEW when applied to data representing a person. Activities publish their Intent Filters in the AndroidManifest.xml file. The new activity is informed of the intent, which causes it to be launched. The process of resolving intents happens at run time when start Activity is called, which offers two key benefits:

Activities can reuse functionality from other components simply by making a request in the form of an Intent.

Activities can be replaced at any time by a new Activity with an equivalent Intent Filter.

### **BROADCAST INET RECEIVER**

You can use a Broadcast Receiver when you want code in your application to execute in reaction to an external event, for example, when the phone rings, or when the data network is available, or when it's midnight. Broadcast Receivers do not display a UI, although they may use the Notification Manager to alert the user if something interesting has happened. Broadcast Receivers are registered in AndroidManifest.xml, but you can also register them from code using Context.registerReceiver (). Your application does not have to be running for its BroadcastReceivers to be called; the system will start your application, if necessary, when a BroadcastReceiver is triggered. Applications can also send their own intent broadcasts to others with Context.sendBroadcast ().

### **SERVICE**

A Service is code that is long-lived and runs without a UI. A good example of this is a media player playing songs from a play list. In a media player application, there would probably be one or more activities that allow the user to choose songs and start playing them. However, the music playback itself should not be handled by an activity because the user will expect the music to keep playing even after navigating to a new screen. In this case, the media player activity could start a service using Context.startService () to run in

the background to keep the music going. The system will then keep the music playback service running until it has finished. Note that you can connect to a service (and start it if it's not already running) with the `Context.bindService ()` method. When connected to a service, you can communicate with it through an interface exposed by the service. For the music service, this might allow you to pause, rewind, etc.

## **CONTENT PROVIDER**

Applications can store their data in files, an SQLite database, or any other mechanism that makes sense. A content provider, however, is useful if you want your application's data to be shared with other applications. A content provider is a class that implements a standard set of methods to let other applications store and retrieve the type of data that is handled by that content provider.

Not every application needs to have all four, but your application will be written with some combination of these.

All the components needed for android application should listed in an xml file called `AndroidManifest.xml`. This is an XML file where you declare the components of your application and what their capabilities and requirements are.

### **Storing, Retrieving and Exposing Data**

A typical desktop operating system provides a common file system that any application can use to store and read files that can be read by other applications. Android uses a different system on Android, all application data are private to that application. However, Android also provides a standard way for an application to expose its private data to other applications. This section describes the many ways that an application can store and retrieve data, expose its data to other applications, and also how you can request data from other applications that expose their data.

Android provides the following mechanisms for storing and retrieving data:

### **Preferences**

A lightweight mechanism to store and retrieve key/value pairs of primitive data types. This is typically used to store application preferences.

### **Files**

You can store your files on the device or on a removable storage medium. By default, other applications cannot access these files.

### **Databases**

The Android APIs contain support for SQLite. Your application can create and use a private SQLite database. Each database is private to the package that creates it.

### **Content Providers**

A content provider is an optional component of an application that exposes read/write access to an application's private data, subject to whatever restrictions it wants to impose. Content

providers implement a standard request syntax for data, and a standard access mechanism for the returned data. Android supplies a number of content providers for standard data types, such as personal contacts.

### **Network**

Don't forget that you can also use the network to store and retrieve data.

## **INTERFACE**

Android's user interface is based on direct manipulation, using touch inputs that loosely correspond to real-world actions, like swiping, tapping, pinching and reverse pinching to manipulate on-screen objects. The response to user input is designed to be immediate and provides a fluid touch interface, often using the vibration capabilities of the device to provide haptic feedback to the user. Internal hardware such as accelerometers, gyroscopes and proximity sensors are used by some applications to respond to additional user actions, for example adjusting the screen from portrait to landscape depending on how the device is oriented, or allowing the user to steer a vehicle in a racing game by rotating the device, simulating control of a steering wheel.

Android devices boot to the home screen, the primary navigation and information point on the device, which is similar to the desktop found on PCs. Android home screens are typically made up of app icons and widgets; app icons launch the associated app, whereas widgets display live, auto-updating content such as the weather forecast, the user's email inbox, or a news ticker directly on the home screen. A home screen may be made up of several pages that the user can swipe back and forth.

Present along the top of the screen is a status bar, showing information about the device and its connectivity. This status bar can be "pulled" down to reveal a notification screen where apps display important information or updates, such as a newly received email or SMS text, in a way that doesn't immediately interrupt or inconvenience the user.

## **APPLICATIONS**

Android has a growing selection of third party applications, which can be acquired by users either through an app store such as Google Play or the Amazon Appstore, or by downloading and installing the application's APK file from a third-party site. The Play Store application allows users to browse, download and update apps published by Google and third-party developers, and is pre-installed on devices.

Purchases of unwanted applications can be refunded within 15 minutes of the time of download, there were more than 675,000 apps available for Android, and the estimated number of applications downloaded from the Play Store was 25 billion.

## **DEVELOPMENT**

Android is developed in private by Google until the latest changes and updates are ready to be released, at which point the source code is made available publicly.[49] This source code will only run without modification on select devices, usually the Nexus series of devices.

[50] With many devices, there are proprietary components which have to be provided by the manufacturer, in order for Android to work.

### **Architecture Diagram**

Android consists of a kernel based on Linux kernel version 2.6 and, from Android 4.0 Ice Cream Sandwich onwards, version 3.x, with middleware, libraries and APIs written in C, and application software running on an application framework which includes Java-compatible libraries based on Apache Harmony. Android uses the Dalvik virtual machine with just-in-time compilation to run Dalvik ‘dex-code’ (Dalvik Executable), which is usually translated from Java bytecode. The main hardware platform for Android is the ARM architecture. There is support for x86 from the Android x86 project, and Google TV uses a special x86 version of Android.

Android’s Linux kernel has further architecture changes by Google outside the typical Linux kernel development cycle. Android does not have a native X Window System by default nor does it support the full set of standard GNU libraries, and this makes it difficult to port existing Linux applications or libraries to Android. Support for simple C and SDL applications is possible by injection of a small Java shim and usage of the JNI like, for example, in the Jagged Alliance 2 port for Android.

Certain features that Google contributed back to the Linux kernel, notably a power management feature called wakelocks, were rejected by mainline kernel developers, partly because kernel maintainers felt that Google did not show any intent to maintain their own code. Google announced in April 2010 that they would hire two employees to work with the Linux kernel community, but Greg Kroah-Hartman, the current Linux kernel maintainer for the stable branch, said in December 2010 that he was concerned that Google was no longer trying to get their code changes included in mainstream Linux. Some Google Android developers hinted that “the Android team was getting fed up with the process,” because they were a small team and had more urgent work to do on Android.

In August 2011, Linus Torvalds said that “eventually Android and Linux would come back to a common kernel, but it will probably not be for four to five years”. In December 2011, Greg Kroah-Hartman announced the start of the Android Mainlining Project, which aims to put some Android drivers, patches and features back into the Linux kernel, starting in Linux 3.3. Linux included the auto sleep and wake locks capabilities in the 3.5 kernel, after many previous attempts at merger. The interfaces are the same but the upstream Linux implementation allows for two different suspend modes: to memory (the traditional suspend that Android uses), and to disk (hibernate, as it is known on the desktop).

The flash storage on Android devices is split into several partitions, such as “/system” for the operating system itself and “/data” for user data and app installations. In contrast to desktop Linux distributions, Android device owners are not given root access to the operating system and sensitive partitions such as /system are read-only. However, root access can be obtained by exploiting security in Android, which is used frequently by the open source community to enhance the capabilities of their devices, but also by malicious parties to install viruses and malware.

### **Memory Management**

Since Android devices are usually battery-powered, Android is designed to manage memory (RAM) to keep power consumption at a minimum, in contrast to desktop operating systems which generally assume they are connected to unlimited mains electricity. When an Android app is no longer in use, the system will automatically suspend it in memory - while the app is still technically “open,” suspended apps consume no resources (e.g. battery power or processing power) and sit idly in the background until needed again. This has the dual benefit of increasing the general responsiveness of Android devices, since apps don’t need to be closed and reopened from scratch each time, but also ensuring background apps don’t waste power needlessly.

Android manages the apps stored in memory automatically: when memory is low, the system will begin killing apps and processes that have been inactive for a while, in reverse order since they were last used (i.e. oldest first). This process is designed to be invisible to the user, such that users do not need to manage memory or the killing of apps themselves. However, confusion over Android memory management has resulted in third-party task killers popular on the Google Play store; these third-party task killers are generally regarded as doing more harm than good.

### **SECURITY AND PRIVACY**

Android applications run in a sandbox, an isolated area of the system that does not have access to the rest of the system’s resources, unless access permissions are explicitly granted by the user when the application is installed. Before installing an application, the Play Store displays all required permissions: a game may need to enable vibration or save data to an SD card, for example, but should not need to read SMS messages or access the phonebook. After reviewing these permissions, the user can choose to accept or refuse them, installing the application only if they accept

The sandboxing and permissions system lessens the impact of vulnerabilities and bugs in applications, but developer confusion and limited documentation has resulted in applications routinely requesting unnecessary permissions, reducing its effectiveness. Several security firms, such as Lookout Mobile Security, AVG Technologies and McAfees have released antivirus software for Android devices. This software is ineffective as sandboxing also applies to such applications, limiting their ability to scan the deeper system for threats.

Research from security company Trend Micro lists premium service abuse as the most common type of Android malware, where text messages are sent from infected phones to premium-rate telephone numbers without the consent or even knowledge of the user. Other malware displays unwanted and intrusive adverts on the device, or sends personal information to unauthorised third parties. Security threats on Android are reportedly growing exponentially; however, Google engineers have argued that the malware and virus threat on Android is being exaggerated by security companies for commercial reasons, and have accused the security industry of playing on fears to sell virus protection software to users. Google maintains that dangerous malware is actually extremely rare. Indeed, a survey conducted by F-Secure showed that only 0.5% of Android malware reported had come from the Google Play store.

Google currently uses their Google Bouncer malware scanner to watch over and scan the Google Play store apps. It is intended to flag up suspicious apps and warn users of any potential issues with an application before they download it. Android version 4.2 Jelly Bean was released in 2012 with enhanced security features, including a malware scanner built into the system, which works in combination with Google Play but can scan apps installed from third party sources as well, and an alert system which notifies the user when an app tries to send a premium-rate text message, blocking the message unless the user explicitly authorises it.

Android smartphones have the ability to report the location of Wi-Fi access points, encountered as phone users move around, to build databases containing the physical locations of hundreds of millions of such access points. These databases form electronic maps to locate smartphones, allowing them to run apps like Foursquare, Google Latitude, Facebook Places, and to deliver location-based ads. Third party monitoring software such as Taintdroid, an academic research-funded project, can, in some cases, detect when personal information is being sent from applications to remote servers.

### Usage share of Android versions

Usage share of the different versions as of January 3, 2012. Most Android devices to date still run the older OS version 2.3 Gingerbread that was released on December 6, 2010, due to most lower-end devices still being released with it.

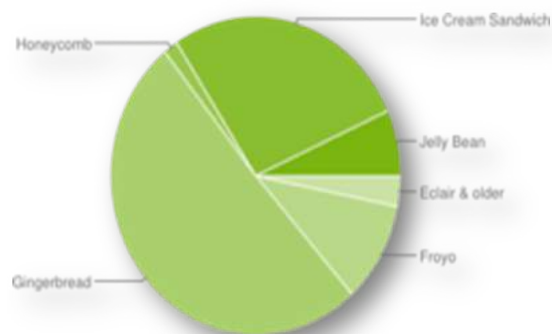

<i>Version</i>	<i>Code name</i>	<i>Release date</i>	<i>API level</i>	<i>Distribution (December 3, 2012)</i>
4.2	Jelly Bean	November 13, 2012	17	1.2%
4.1.x	Jelly Bean	July 9, 2012	16	9.0%
4.0.x	Ice Cream Sandwich	December 16, 2011	15	29.1%
3.2	Honeycomb	July 15, 2011	13	1.1%
3.1	Honeycomb	May 10, 2011	12	0.4%
2.3.3–2.3.7	Gingerbread	February 9, 2011	10	47.4%

<i>Version</i>	<i>Code name</i>	<i>Release date</i>	<i>API level</i>	<i>Distribution (December 3, 2012)</i>
2.3–2.3.2	Gingerbread	December 6, 2010	9	0.2%
2.2	Froyo	May 20, 2010	8	9.0%
2.0–2.1	Eclair	October 26, 2009	7	2.4%
1.6	Donut	September 15, 2009	4	0.2%
1.5	Cupcake	April 30, 2009	3	0.0%

## **CONCLUSION**

Finally we concluded that the Androids platform which has developed by Google is going to play major role in Mobile applications because as it is an open source and it is also easy to develop mobile applications using Android as because in order to develop these applications all the APIs are available and these APIs are as same as java APIs which are easy to understand.

## **REFERENCES**

- [1] “Hello, Android” author Ed Burnette
- [2] “Learning Android” author Marko Gargenta
- [3] “Professional Android 2 Application Development” author Reto Meier
- [4] “Building Android Apps with HTML, CSS, and JavaScript” author Jonathan Stark
- [5] “Android Database Programming” author Jason Wei
- [6] Website - [www.android.com](http://www.android.com)
- [7] Website – [www.androidcommunity.com](http://www.androidcommunity.com)
- [8] Website –[www.talkandroid.com](http://www.talkandroid.com)

# An Insight into Influencing Factors Towards Buying Behaviour of Fast Moving Consumer Goods by Rural Consumers

PRADEEP KUMAR MISHRA<sup>1</sup> and N.L. Mishra<sup>2</sup>

## Abstract

*Rural Consuming system and its evolution are different from that of urban consumption. Material prosperity in the rural India due to the effect of liberalization and globalization resulted in increased production and improved transportation and communication facilities. Increased rural development investment has increased the purchasing power of the rural folks. The increased purchasing power changes the dynamics of rural consumption behavior. Thus, it is worth to examine how the rural consumers are being motivated, how far these determinants differ from urban consumers and how far the socio-economic, cultural factors are influencing the rural consumers. A thorough understanding of rural consumer buying behavior would help in identifying different market segments and to evolve suitable marketing strategies for effectively penetrating and thereby to command and respectable share in rural markets.*

*This paper focuses on understanding factors that affect the rural purchase of FMCG in South India. Empirical study was conducted in 8 districts of South India to identify the key influencing variables. Factor analysis was used to form 24 key variables into five groups (influencing factors). Influence of retailers' recommendations has emerged as the most significant variable in the trust factor. According to the study, rural consumers in South India consider that usage of FMCG contributes to their lifestyle.*

**Keywords:** Price Points, Brand Visibility, Rural Purchase, Buying Behaviour, Fast Moving Consumer Goods

## INTRODUCTION

Consumption is the soul and the purpose of all production. So Peter Drucker was apt in saying, "it is the consumer who determines what the business is". A consumer is one who does some physical activities and deliberates to take decisions concerning purchase and to dispose off on to evaluate the products and services. Consumer Behaviour reflects the totality of consumer's decision with respect to acquisition, consumption and disposition of goods, services, time and idea by (human) decision making units (over time). It also

<sup>1</sup> Research scholar, Faculty of Rural Development and Business Management, M.G.C.G. Vishwavidyalaya, Chittrakot, Satna (MP).

<sup>2</sup> Associate Professor Faculty of Rural Development and Business Management, M.G.C.G. Vishwavidyalaya, Chittrakot, Satna (MP).



includes whether, why, when, how, where, how much and how often and how long consumer will use or dispose of an offering. The markets are customer driven these days and the target of all marketing activities is consumers. To understand the consumers, are not easy jobs as his behaviour is mostly unique and unpredictable. This has made the firms to step into the shoes of the customer and understand from his point of view selection and purchase of products and services and frame marketing plans than considering the wholesalers and retailers who actually are the intermediaries in the process of purchase. Marketers therefore should consider the consumers and then develop their plans of actions. Here lies the essence of marketing. The consumer is the kind and all actions should start with this notion in mind.

Market structure in India is dichotomous having rural and urban markets. There are certain unique characteristic features which call for separating marketing strategies to be distinctly developed to suit to rural and urban marketing behaviours. This is especially because rural consumers differ in terms of its consumption pattern, purchase decisions, purchase behaviour, attitudes and perceptions towards products. The dominant economic peculiarities of rural India may also be recognized in terms of the source of income (agriculture), the frequency of receipt of income (unstable because of the dependence of monsoon) and the seasonal nature of income and consumption (mainly farmers). These differences also affect the consumption pattern of rural consumers.

Indian rural markets are estimated to be growing quickly compared to urban markets. Being a new market, it could easily mend; provide the manufacturer to develop an insight into the behavioural pattern of the rural consumers. The potentials of rural markets is said to be like a woken up sleeping giant. Currently rural markets account for 53 percent of fast moving consumer goods, 100 percent agricultural products and 59 percent of durable goods markets in India. This stresses the need for developing and offering products that are tailored to meet the needs of rural consumers.

## **RURAL MARKETING IN INDIA**

A couple years ago, the term rural marketing is to be unheard but with rapid globalization, the development programmes of the Government in infrastructure, agriculture, education and cut-throat competitions among Multi-National Companies (MNC's) and home industries, the importance of rural marketing becoming more pronounced.

Now, the think tank of big companies giving more and more priority to rural marketing. The villages and small towns, which were once in consequential dots on maps, are now getting the attention of global marketing giants and media planners thanks to globalization, economic liberalization, IT revolution, female empowerment, and improving infrastructure middle class rural India today has more disposable income than urban India. Rural marketing is gaining new heights.

Formulating rural marketing strategy requires understanding of the rural markets and the significant rural-urban differences and similarities. Rural marketing philosophy should embody marketing concept and societal concept. Relationship marketing and development marketing take precedence over transactional marketing. New approaches to marketing

research and understanding consumer behaviour are needed.

A marketing-mix targeted to lower and middle income groups may be suitable, in case of some products. In other cases, altogether a different strategy becomes necessary. Rural marketing relies mostly on low priced, small unit packs and quality durables without frills, distribution by outlets like cooperatives, Non-Government Organization (NGOs), self-help groups, haats and melas and promotion through interactive media using local idiom and region-specific dialect.

What is rural marketing? Is rural marketing different from urban marketing? Is there any difference between marketing into rural areas and rural marketing? What is the optimum mix of marketing variables for rural marketing? Is the rural 'psyche' different from the urban one?

All these together invariably bring in the question of defining the domain of rural marketing. The marketing concept has to be made relevant to the rural environment considering the dynamics of interactions in rural India on such questions, as is it a habit at or a transaction relationship? Those in turn bring in the task of operationalizing the marketing concept and/or consider marketing as a concept very different from purchasing and selling. Among the various factors that have made rural markets attractive are large populations, raising prosperity, growth in consumption, life style changes, product life-cycle advantage, relatively high market growth rates, cost effectiveness of rural marketing and convenience in reaching rural areas.

Marketers so far relied only on the trickle-down theory, considering rural market as a passive segment dependent on urban feeder town. However, as it started showing promise, they employed the urban marketing strategies with suitable modification. Learning from experience, many marketers are advocating a differentiated approach to attract and retain rural consumers.

In recent days in India consumer is at the point where there is a multiplicative effect of income growth, aspiration to consume and changed consumption friendly ideology/ social discourse across the income board, especially in rural India. Hence, the buying behaviour of rural consumers has become a hot-topic for discussion because rural India, in recent days, is enthusiastically consuming everything from shampoo to motor cycles and this "rural predilection" is being considered as one of the significant topics of market analysis. Besides, we know well that purchase decisions in Indian homes have become a collective process with women and teenage children playing a major role on product and brand choices. Decision-making has become a joint process in the family; woman is the initiator and / or product evaluator, man the financier and child, an influencer.

Hence, the market analysts are adopting both the "product window" approach and "Consumer or People Window" approach forgetting an insight into the structure and drivers of consumer demand particularly in rural India. The first approach deals with the perspective of "how much of what is being bought" and the latter deals with "how many of what kind of people are buying". The thrust is on not just what is being bought but also who is buying and the analysis has to be made considering both "product segments" and "consumer segments".

## LITERATURE REVIEW

**Mohan S. and Venilla S (2016)** in their paper concluded that rural consumers buy the FMCG through retailer in their village. The present study proved that the retailers are aware of the fact that their customers listen to them. They are the one who can create their interest in product. It as price influences rural purchase of FMCG, it is recommended to the low-price strategy in rural marketing for rural customers, value for money is very important when they purchased FMCG. The study revealed that the rural customers are not only price sensitive but also think about quality, performance, reliability, branded another critical aspects. It is rationality rather than just making low price appeal rural markets should design innovative promotional strategies for rural markets that can express message in an easy way to the villagers and compatible with their education and understanding levels. Rural consumers are highly affected by their lifestyle and attitude, Rural marketing is highly influenced by celebrity endorsement and should take care of this and take hat celebrity who is popular in rural areas.

**Aggarwal (2014)** suggested that Consumer behaviour research is the scientific study of the processes consumers use to select, secure, use and dispose of products and services that satisfy their needs. Firms can satisfy those needs only to the extent they understand their customers. The main objective of this paper is to study the demographic differences in consumers' buying behaviour of persons living in Madhya Pradesh and when they buy FMCG products. To attain this objective a survey was developed and administered across some part of Madhya Pradesh. The findings confirm the factors influencing consumer buying behaviour for tooth paste brands available in the market

**Rana J. (2012)** studied that; the Indian market is quite attractive and challenging. Although the marketers are taking effective steps to capture this market. Still there is a large scope. It has tremendous opportunities. As far as premium F.M.C.G. brands are concerned, only a few consumers are there form this market. The companies should decide their target market for premium brands and approach them. Youth can be a great help in this direction. The marketers have to come up with innovative proposals through which the target market (for premium brands) should be convinced.

**Gupta S.L. et al. (2012)**, in his study he found that, the responses of customers are quite mixed in the rural India. Customers prefer some of the popular brands but they also prefer to use local brands. The loyalty status for brands is also moderate in the rural markets. It seems that customers do not bother more about the purchase decision of F.M.C.G. product. The house makers and other members of the family influence the purchase decision. Rural area people have enough time to talk with their friends and social groups so their decisions are also influenced the reference groups. In brief we can say that the consumer in rural markets is not so sophisticated and not conscious about the brands and purchase decision. This shows an opportunity for the marketers to promote their products by the promotional strategies, which can make a place in the heart of the customers. Some of the companies with local brands win the battle by convincing the retailers about the product. Retailers sometimes work like a salesperson for that company and recommend the product to the customer because they get a smart margin for this. Further the local companies also give discount for space in the shelf of shopkeeper.

**Kulkarni and Dr. Hundal B (2011).**, concluded in his study that, the rural market in India is quite fascinating and challenging in spite of all the difficulties existing. The potential is enormous. Even though, these markets have weaknesses, they also have tremendous opportunities which should be availed by the marketers. It is well known that “Markets are created and not born”. The market so created should be tapped effectively. The rural consumers are different than the urban one. It is important for the rural marketers to understand the rural markets and consumers to be successful in the rural markets. There are companies like H.U.L., ITC and LG which are successful in the rural markets. The rural tiger is awaking the companies need to work on the controllable factors to face the challenge successfully.

**Bardia G (2010).**, suggested that in their study, it can be said that rural marketing is still in its initial stages and the rural population has shown a trend of wanting to move into a state of gradual urbanization in terms of exposure, habits, lifestyles and consumption patterns of goods and services. The success stories of 502 Pataka Chai, Ghari Detergent and Britannia Tiger biscuits do indicate that realization of specific needs of rural customers and differentiating their marketing strategies from those of the urban populace can work wonders for any company.

**Iyer V (2009).**, found that, rural markets, as part of any economy, have untapped potential. There are several difficulties confronting the effort to fully explore rural markets. The concept of rural markets in India, as also in several other countries, is still in evolving shape, and the sector poses a variety of challenges, including understanding the dynamics of the rural markets and strategies to supply and satisfy the rural consumers.

**Dr. Anandan C. et al (2007)** concluded that in his study that, India’s rural markets have seen a lot of activity in the last few years. Since penetration levels are pretty high in most categories, future growth can come only from deeper rural penetration. Rural marketing has become the latest marketing mantra of most F.M.C.G. majors. True, rural India is vast with unlimited opportunities, waiting to be tapped by F.M.C.G. majors. To gain advantage of this, the Indian F.M.C.G. sector is busy putting in place a parallel rural marketing strategy. F.M.C.G. majors are aggressively looking at rural India since it accounts for 70% of the total Indian households. Today, India has a diverse range of detergents available off the shelf. The annual consumption of detergents in India ranges to thousands of tones. The formal sector with its increasing ability to influence consumers via advertisements is expanding its market share aggressively. The detergent market has evolved into a highly competitive one where myriad brands vie with each other to get the customers’ attention. Each brand claims to clean whiter, boasting of technologically dubious terms such as fighting granules, power pearls, etc. This study aims at finding the factors influencing the rural customers to prefer a particular brand in detergent soaps. This study concludes with suggesting the strategic framework for Marketers to win over the hearts of the rural customers.

**Ritesh Sud and Pritesh Y. Chothani (2006)** studied that there has been a significant rise in the brand awareness among the people in the rural markets. As a result they are becoming choosier and demanding than ever before, so any company has to properly analyze the psychographics before entering this market. Studies indicate that there has been a visible shift in the people’s preference for brands. People are upgrading from the use of

tooth powders to tooth pastes, and from using traditional mosquito repellants to using mats and coils. Also there is shift from low priced brands to semi premium brands.

**Jain A. and Rathod R. (2005)** concluded in their research paper that, the Indian rural market with enormous size and demand base, offers great opportunities to marketers. With nearly three fourth of the country's consumers accounting for one half of the national income, India's rural market is indeed a large one. Talking in numerical terms it consists of more than 741 million consumers, and more than 12 crore households, forming over 70% of the total households in the country. As the rural market becomes more attractive competition will intensify and success will depend on reaching a large no of customers in vast geographical area cheaply and profitably.

**Lokhande D.M (2004)**, found in his study that, everyone needs a variety of goods and services from the birth. Marketing is a process through which both the buyer and seller give something (e.g. goods, services, money etc.) to each other for maximum possible satisfaction. Nowadays, Rural Marketing is gaining importance. Author put details the potential of rural markets. Rural consumption share in popular soaps is 48%, tooth pastes 24%, talcum powder-17%, cold medicines-42%, Batteries-52%, etc. The Market for Packaged food items of Rs. 20,000 cr. is growing at 2.5% per year. It is interesting to understand the various aspects of the rural markets and consumption patterns.

## **RESEARCH GAP**

Though the currently available literature on influencing factors seemingly appears to be adequate, still a lot of research needs to be done inspecific geographic rural markets (Jha, Mithileswar, 2003; Bijoor, Harish 2004) as the rural consumer behavior varies in various product categories and geographic markets (Sinha, 2008). Respected as an expert in rural marketing in India, Rajan, R.V., opined that a lot of study still needs tobe conducted as understanding of rural consumers, even after two decades, remains partial and superficial. Though studies are conducted on various aspects like, challenges in rural markets (Khatri, 2002), advertising issues in rural marketing (Balakrishnan, 2007), importance of creativity in message generation and message execution while communicating with rural markets (Bansal & Easwaran, 2004) and general issues relating to rural markets (Bijapurkar, Rama, 2000), still there is a lot of scope for studying many moreissues relating to influencing factors in rural markets. The literature review conducted for the current research makes it clear that very less research is done on rural consumer behavior with respect to factors influencing the purchase and consumption of FMCG, by the Indian rural consumers, either in general or with reference to South India. Hence, it is decided to conduct asurvey with reference to FMCG purchase behavior of rural consumers in Chitrakoot Dham region of North India.

## **OBJECTIVE OF THE STUDY**

Main objective of the current study is:

- (a) To get insight into the variable related to consumer buying behavior for Fast Moving consumer goods in Rural areas.
- (b) To identify and extract the factors influencing the purchase of FMCG by rural

consumers in North India especially in Chitrakoot Dham.

**RESEARCH METHODOLOGY**

Primary data is collected through administering a well-structured questionnaire consisting of 5-pointscale. For the convenience of the respondents, the questionnaire is translated into the regional language, Hindi. The researcher also included schedule method for collecting the data in some cases particularly when the respondent is less educated or uneducated. The survey is limited to a regioncalled Chitrakootdham (district) particularly in different villages like Kalupur, Taraon, Nayachandra, Itwa, Bandhi, Jorvara, Harra, Panauti, Alwari, Chhibonand various Villages in Chitrakootdham. The **sample size** for this study is taken to be 540.

The researcher based on explorative study, has considered the following 24 variables that can (combination of variables can) impact the buying behavior of the rural consumers.

**Table 1:** Variables Influencing the Rural Purchase of FMCG

<i>Sl. No</i>	<i>Variables identified</i>	<i>Sl. No</i>	<i>Variables identified</i>	<i>Sl. No</i>	<i>Variables identified</i>	<i>Sl. No</i>	<i>Variables identified</i>
1	Shop Keeper’s Recommendation	7	Need based	13	Packaging	19	Brand loyalty
2	Friend’s recommendation	8	Brand Awareness	14	Product education & demonstrations	20	Size
3	Low price	9	Relationship Marketing	15	Brand endorsements	21	Shelf display
4	Affordability	10	Promotions	16	Quality	22	Intended benefits
5	Long Lasting	11	Dignity	17	Government Promotions	23	Free offers/sales promotions
6	More features offering more benefits	12	Availability	18	Lifestyle	24	Brand Visibility

**Table 2:** Titles of Factors With Influencing Variables & Respective Factor Loadings

<i>Factor</i>	<i>Variables</i>	<i>Factor Loading</i>
Effective Promotional Communication	Promotions	0.948
	Relationship Marketing	0.908
	Product education	0.899
	Free offers/sales promotion	0.892
	Brand endorsement	0.867
	Shelf display	0.805

<i>Factor</i>	<i>Variables</i>	<i>Factor Loading</i>
Effective Style Of Living	Brand awareness	0.842
	Packaging	0.840
	Dignity	0.811
	Brand visibility	0.793
	Life style	0.745
Effective Trustworthy	Friend's recommendations	0.828
	Brand loyalty	0.786
	Government Promotions	0.785
	Shopkeeper's Recommendations	0.779
	Availability	0.741
Effective Value	Intended benefits	0.875
	Affordability	0.857
	Need Based	0.821
	Low Price	0.757
Effective Product	More features	0.776
	Size	0.720
	Quality	0.708
	Long Lasting	0.616

### **Sample Unit**

For the current research consisted of rural population living in villages who are both buyers and consumers of FMCG.

### **Testing of Questionnaire**

It is suggestible to test the validity and reliability of the questionnaire (McClave et al., 2008; Malhotra, 2007). Pilot study was conducted to test the questionnaire. The sample size considered for pilot study is 60. On the basis of pilot study, the researcher can able to finalize the variables that can be proceeded further for factor analysis.

### **Data Analysis Tools and Techniques**

Factor Analysis was conducted on SPSS 16.0 software, to identify the factors that influence the FMCG purchase decision of rural consumers (Luck & Rubin, 2007). Secondary data is collected from various valid sources such as websites of FMCG companies, books and articles on rural marketing, reports of consultancy companies and Government sourced from libraries. However, Internet is the major source of secondary data.

**Data Analysis and Interpretation**

Objective of this research was to identify the variables along with underlying factors influencing the purchase decisions of rural consumers with reference to purchase of FMCG. Twenty four variables influencing the rural purchase of FMCG were identified after a detailed literature review. Table 2 presents all the variables:

**Test Statistic**

**Table 3:** KMO and Bartlett’s Test of Sphericity

Kaiser-Meyer-Olkin Measure of Sampling Adequacy	0.855
Bartlett’s Sphere of Sphericity	17524.034
Approx. Chi-Square	
Df	153
Sig.	.000
Normally, $0 < KMO < 1$ Here $KMO > 0.5$ , the sample is adequate. Here, $KMO = 0.855$ which indicates that the sample is adequate and we may proceed with the Factor Analysis.	

Bartlett’s test of Sphericity resulted in a large value(17524.034) which indicates that the variables donot correlate with each other. KMO Statistic, the measure of sampling adequacy is 0.855. These two values allow the application of factor analysis (Malhotra, Naresh, 2007). Using the “eigen value greater than 1” criteria, 5 factors were formed explaining a total variance of 71.05%. Based on high loading in the Rotated Component Matrix and similarity between the variables in the same column, five factors were selected presented inTable 2.

**ANALYSIS AND INTERPRETATION OF THE FACTORS AND VARIABLES**

**Factor 1: Effective Promotional Communication**

*Promotions and advertisements* emerged as key influencing variables in the Promotion Factor (0.948 factor loading). Hence, it is suggested that highest preference has to be given to promotional activities (Shapiro et al., 1987). *Relationship marketing* by companies does influence the purchase decisions by the rural consumers (0.908 factor loading). Companies take up relationship activities as a part of their PR (Public Relations) programs (Arens, 2006). It can be interpreted that the relationship activities serve as promotional strategies in rural marketing. Rural marketers’ attempts to *educate* customers regarding various aspects of the product/brand do influence the rural purchase decisions (Krishnamurthy, Jagadeesh, 2009). The same is empirically proven in the current research. With a loading of 0.899, this variable forms a part of Promotion Factor. *Sales promotions* can play an important role (Dhunna, Mukesh, 1984) as the rural customers can get attracted by various sales promotion techniques like, free offers (Anand & Hundal, 2008). Current research



proves that this variable significantly contributes to the Promotion Factor with 0.892 factor loading. *Brand endorsements* also emerged as an important variable in Promotion Factor with a loading of 0.867. Rural marketers can use celebrity endorsements as a part of their product promotions. *Shelf display* contributes to promotion of FMCG. With a factor loading of 0.805, it emerged as one of the key variables contributing to the Promotion Factor. Visibility in the retail outlet is a very important aspect (Young & Robinson, 1992). Customers take decisions basing on the visibility of a FMCG on the retail shelves (Rakesh et al., 2008).

### **Factor 2 :Effective Style of Living**

Current research proved that the rural customers link purchase and consumption of FMCG to the improvements in their lifestyles. Brand awareness is the 'key' (0.842 factor loading) as, creating awareness is more important in rural marketing (Ramana Rao, 1997). Packaging influences rural purchasing decisions (Sehrawet & Kundu, 2007). Since, in the current research, packaging has emerged as one of the important variables influencing rural lifestyle (with 0.840 factor loading), it can be interpreted that the rural consumers attach their lifestyle or standard of living to the better/attractively packed goods. Further in the survey, it is proved that the rural consumers prefer to buy FMCG that make them feel dignified while buying/possessing/using them. And that feeling adds to their lifestyle (0.811 factor loading). Brand visibility is also included in Lifestyle Factor (with a loading of 0.793). It can be interpreted that, if the marketers can create brand visibility for their FMCG, it contributes to creating awareness and further to the lifestyle of the rural consumers. Thus the current research empirically proves that rural consumers opine that consumption of FMCG enhances or adds to their lifestyle.

### **Factor 3: Effective Trustworthy**

With a factor loading of 0.828, friend's recommendation emerged as a key variable in the Trust Factor. Thus, it is proven that rural customers respect and follow the recommendations of their friends and relatives to try or buy an FMCG. Brand loyalty is noticed in rural markets as it is proven that the rural customers prefer to buy brands of FMCG that they have been using (0.786 factor loading). Government (0.785 factor loading) is one of the trusted sources for rural people. Rural customers trust and buy brands/products that are promoted by Government. Companies that incorporate their products/brands in various government policies will be able to influence the rural purchasing decisions. As the relationships between shop keepers and their customers are strong in rural areas (Khatri, 2002), rural people believe shop keepers. The current research categorizes shop keeper's recommendation as one of the influential variables in rural buying (0.779 factor loading). In rural marketing, availability is the key to success (Ramanathan, 2007). Availability formed a part of Trust Factor. It can be interpreted that, if a sought after FMCG is not available, the rural consumers may lose trust in it.

### **Factor 4: Effective Value Factor**

It is found that the rural consumers seek value in their purchase of FMCG. According

to them, the FMCG that are affordable (0.857 factor loading), low priced (0.757 factor loading) and fulfill their intended benefits (0.875 factor loading) are ‘value products’. It is also proved that the rural consumers buy FMCG only when needed (0.821 factor loading).

**Factor 5: Effective Product**

The product factor influencing the rural purchase is loaded with four important variables, more features (0.776), size of the FMCG (0.720), better quality (0.708) and long lasting FMCG (0.616). Thus it can be interpreted that the rural customers seek multiple features in a product and at the same time look for bigger sized FMCG. It is once again proven that rural people seek quality (Pralhad, 2005).

**Table 2:** Reliability of Factors Influencing Rural Purchase of FMCG

<i>(student)</i>	<i>Cronbach's Alpha</i>	<i>No. of Variables</i>
Overall reliability	0.821	24
Reliability of factor 1	0.953	6
Reliability of factor 2	0.886	5
Reliability of factor 3	0.859	5
Reliability of factor 4	0.860	4
Reliability of factor 5	0.711	4

**Reliability Analysis**

Reliability analysis included calculation of Cronbach’s Alpha that measures the internal consistency and reliability of the instrument (Simon & Burstein, 1985). In the current research, the Cronbach’s Alpha for all variables (24 items) is 0.821. Similarly, for each of the factors the Cronbach’s Alpha is higher than 0.7 which indicates the significance of the model. Details are represented in Table 2.

**CONCLUSIONS AND RECOMMENDATIONS**

Rural customers trust retailers in their villages. During the field visits, it is observed out that though the retailers are aware of the fact that their customers listen to them, they are not aware of this wonderful principle called, the ‘Trust Factor’. The companies must educate rural retailers about such modern marketing principles for a better performance. As price influences rural purchase of FMCG, it is recommended to pursue the low-price strategy in rural marketing. Attaining low price not only requires low-cost manufacturing but also performing various marketing activities such as promotion and distribution in a cost effective manner. It is also recommended to promote goods on price plank. For rural customers, value for money results when the purchased FMCG meets the intended benefits. As the study revealed that the rural customers (along with price) also think about quality, performance, reliability, brand and other critical aspects, it is recommended to promote FMCG in lines of rationality rather than just making low price appeals. Rural marketers

should design innovative promotional strategies for rural markets that can express messages in an easy way to the villagers and compatible with their education and understanding levels. It is recommended to offer FMCG that lasts long. Rural consumers associate long lasting feature with bigger size and/or hardness of the product. Hence, it is suggested to promote FMCG in these lines. Quality is important in the context of rural purchase and consumption of FMCG as rural customers prefer quality FMCG. Experts like, Harish Bijoor, Rama Bijapurkar and C.K. Prahalad and many researchers have been emphasizing on this fact. Hence, it is recommended not to compromise on the quality of FMCG. Low prices have to be charged while maintaining the quality. Preference for attractive packaging is noticed in rural marketing. Packaging creates a favorable impression in rural customers' minds which impacts their buying behavior. Rural people would remember an FMCG by its packaging. It is recommended to allot great deal of attention towards designing attractive packaging while keeping the costs low. Also the rural marketers can promote their FMCG on the basis of attractive packaging. It is recommended that rural marketers should devise their strategies in alignment with Government's rural development programs and form their marketing communications a part of information related to that specific policy. This is because, the rural people believe in messages that come from Government. It is also recommended to organize product demonstrations as a proof of product functioning and also to educate rural customers. As celebrity endorsements work in rural marketing, it is recommended to use low-cost advertisement strategies like making use of animated celebrity characters. Other suggestions include, maintaining quality, devise and implement sales promotion campaigns, apply retail strategies like shelf display, apply CRM techniques like consumption points, etc.

#### **SCOPE FOR FUTURE RESEARCH**

Future is bright for rural research particularly in FMCG category. Research can be done to suggest how marketing of FMCG in rural areas in India can also be performed through encouraging rural entrepreneurship. The existing business models for different industries e.g. Project Shakthi by HUL can be studied and further improvised models can be built and tested with reference to marketing of FMCG in rural areas. Also in future research can be oriented towards each sub-category of FMCG like, haircare, child-care, house cleansers, premium product categories like, colour cosmetics and body deodorants, etc.

#### **REFERENCES**

- [1] Anand and Hundal, B.S. (2008), "Perceptions of consumers towards promotional schemes for durables: A study in Punjab", *The ICFAI University Journal of Consumer Behavior*, Vol.3 No. 2, 17-31.

- [2] Anand, Sandeep and Krishna, Rajnish (2008), "Rural brand preference determinants in India", In *Conference on Marketing to Rural Consumers – Understanding and tapping the rural market potential*, IIMK, pp. 1-5.
- [3] Arens, F. William (2006), *Contemporary Advertising, 10 e*, McGraw-Hill/Irwin, New York.
- [4] Bhatt, Rajeshwari G. and Jaiswal, M. C. (1986), "A study of an advertising impact and consumer reaction", *Indian Journal of Marketing*, Vol.18, pp. 9-16.
- [5] Bijapurkar, Rama (2000), "The Marketing in India", *The Economic Times*, September 18, p. 6.
- [6] Bijoor, Harish (2005), "Creating brand strategies for rural India", *Deccan Herald*, July, 4.
- [7] Bishnoi, V.K. and Bharti (2007), "Awareness and consumption pattern of rural consumers towards home and personal care products", In *Conference on Marketing to Rural Consumers*, IIM K, pp. 93-106.
- [8] Dhunna, Mukesh (1984), "An analysis of consumer behavior—A case study of soft drinks", *Indian Journal of Marketing*, Vol.14, pp. 26-28.
- [9] FICCI Technopak (2009), FMCG Sector The Road Ahead, Massmerize, Conference on Fast Moving Consumer Goods, pp. 3-12.
- [10] Jha, Mithileshwar (2003), "Understanding rural buyer behavior", *IIMB Management Review*, Vol.15 No. 3, pp. 89-92.
- [11] Kashyap, Pradeep and Raut, Siddharth (2007), "*The Rural Marketing Book*, Biztantra Khatri, M (2002), "Challenges in rural marketing", *Strategic Marketing*, July-Aug, 2002.
- [12] Kothari, C.R. (2004), *Research Methodology Methods and Techniques, 2e*, New Age International (P) Ltd., New Delhi, pp. 152-232.
- [13] Kotler, P., Keller, K. L., Koshy, A. and Jha, Mithileshwar (2009), *Marketing Management A South Asian Perspective*. 13 ed., Pearson Education, New Delhi.
- [14] Krishnamoorthy, R (2008), *Introduction to Rural Marketing*, Himalaya Publishing House, Mumbai
- [15] Krishnamurthy, Jagadeesh (2009), "The challenges and opportunities of marketing in rural india", *Events Faqs Newsletter (EF)*, December, pp. 14-18.
- [16] Kumar, S.A. and Madhavi, C. (2006), "Rural marketing for FMCG", *Indian Journal of Marketing*, Vol. 36, No. 4, pp. 19-38.
- [17] Kumar, Sanjeev and Bishnoi, V.K. (2007), "Influence of marketers' efforts on rural consumers and their mindset: a case study of Haryana", *The ICFAI Journal of Brand Management*, Vol. 4 No. 4, pp. 28-50.
- [18] Luck, D.J. and Rubin, Ronald S. (2007), *Marketing Research, 7e*, Prentice Hall of India Pvt. Ltd., New Delhi.
- [19] Malhotra, Naresh K. (2007), *Marketing Research An Applied Orientation*, Prentice Hall of India Pvt. Ltd., New Delhi
- [20] McClave, T. James, Benson, P. George and Sincich, Terry (2008), *Statistics for Business and Economics, 10 ed.*, Pearson Education Inc, New Jersey, USA, pp. 10-11.
- [21] Mitra R. and Pingah, V. (2000), "Consumer aspirations in marginalized communities: a case study in Indian villages", *Consumption Markets and Culture*, Vol. 4 No. 2, pp. 125-144.
- [22] Mohan S & Venilla S (2016), "Rural Consumer Behaviour for FMCG", *Journal of Exclusive Management Science*, March 2016, pp 1-6.
- [23] Narang, R. (2001), "Reaching out to the rural markets of Uttar Pradesh", *Indian Management Studies Journal*, Vol. 5, pp. 87-103.
- [24] Nielsen White Paper (2012), *Emerging Consumer Demand: Rise of the Small Town Indian*, Nielsen White Papers, India.

- [25] Pandey, D.P. (2005), "Education in rural marketing". University News, vol. 43, pp. 7-8.
- [26] Prahalad C. K. (2005), *The Fortune at the Bottom of the Pyramid*, Wharton School Publishing.
- [27] Ramana Rao, P.V. (1997), "Rural market problems and perspective", *Indian Journal of Marketing*, Vol. 27, pp. 17-19.
- [28] Ramanathan, V. (2007), "Retailing channel enhancement strategies adopted by FMCG companies in South Indian rural markets", *The ICFAI Journal of Management Research*, Vol. 6 No. 11, pp. 64-70.
- [29] Sahoo, S.K. and Panda, J.P. (1995), "The rural market and rural marketing in India: Challenges and strategies", *Indian Journal of Commerce*, Vol. 18, pp. 185.
- [30] Sarangapani, A. and Mamatha, T. (2008), "Rural consumer: Post purchase behavior and consumer behavior", *The ICFAI Journal of Management Research*, Vol. 7, No. 9, pp. 37-67.
- [31] Sayulu, K. and Ramana Reddy, V.V. (1996), "Socio-economic influences on rural consumer behaviour – An empirical study", *Management Researches*, Vol. 3, pp. 41-51.
- [32] Sehrawet, Mahavir and Kundu, Subhash C. (2007), "Buying behaviour of rural and urban consumers in India: The impact of packaging", *International Journal of Consumer Studies*, Vol. 31 No. 6, pp. 630-638.
- [33] Shapiro, B.P., Rangan, V.K., Moriarty, R.T. and Ross, Elliot (1987), "Manage customers for profits (not just sales)", *Harvard Business Review*, Vol. 65 No. 5.
- [34] Simon, J.L. and P. Burstein (1985), *Some Principles of Measurement*. New York Random House.
- [35] Singh, H., Singh, P., Badal, O, Singh, S., and Sen, C. (2008), "Problems and prospects of food retailing in the state of Uttar Pradesh (India)", *Journal of Services Research*, Vol. 8, No. 2, pp. 91-99.
- [36] Sinha, M. (2008), "Walk their walk and talk their talk: The mantra of success in the hinterland", *The ICFAI University Journal of Marketing Management*, Vol. 7 No. 4, pp. 7-23.
- [37] Technopak Perspective (2009), *A quarterly report by CII-Technopak*, Vol. 2., pp. 1-23
- [38] Vaswaniet al. (2005), "Rural Marketing in Development Paradigm", *International Conference on Marketing Paradigms for Emerging Economies*, IIM-A, Jan 12-13.
- [39] Velayudhan, S. (2002), *Rural Marketing-Targeting the Non-urban Consumer*, Response Books, Sage Publications India (P) Ltd., New Delhi,
- [40] Venkatesh, G. (2004), "Technology, Innovation and rural development", *IIMB Management Review*, Vol. 16 No. 4, pp. 23-30
- [41] Young, C. and Robinson, M. (1992), "Visual connectedness and persuasion", *Journal of Advertising Research*, Vol. 32 No. 2, pp. 51-59.
- [42] Zhao, Y. (1994), *Price dispersion and retailer behavior*, Doctoral dissertation, University of California, Berkeley.

# Finite Termination by Using the Asymptotic Dual for Dynamic Bundle Method

PARAS BHATNAGAR<sup>1</sup> AND PRASHANT CHAUHAN<sup>2</sup>

## Abstract

*This research paper deals with the question of finite termination of the Algorithm for Dynamic bundle method. For a polyhedral dual function  $f$ , if the stopping parameter is set to  $\text{tol} = 0$ , and the bundle management is either “no bundle deletion” or “bundle selection”, we provide a positive answer for that question.*

**Keywords:** Polyhedral Dual Function, Dynamic Bundle Method, Minimization Problem

## INTRODUCTION

We proceed somewhat similarly to Kiwiel.[1], we will show finite termination by using the asymptotic dual results to obtain a contradiction.

Our main assumption is that there exists a finite number  $q$  of primal points,

$$\{p^1, p^2, \dots, p^q\} \subset Q,$$

such that the dual function can be written as

$$f(x) = \max_{i \leq q} \{C(p^i) - \langle g(p^i), x \rangle\}, \quad (1)$$

i.e., the dual function is polyhedral.

Although this assumption is made on the dual function, there are many primal conditions that ensure the form (1) for  $f$ .

Condition (1) implies that at each given  $x^i$  there are at most  $q$  different maximizers  $p^i$  as in (4), yielding a finitely generated subdifferential

$$\partial f(x^i) = \text{conv}\{-g(p^i) : p^i \text{ and } i \leq q\},$$

Likewise, bundle elements corresponding to past dual evaluations, i.e,

$$\{C_i = C(p^i) : p^i \in Q\} \text{ where } i \leq q,$$

can only take a finite number of different values. This is not the case for aggregate elements, which can take an infinite number of values, simply because they have the expression

---

<sup>1</sup> GL Bajaj Institute of Technology and Management, Greater Noida (UP).

<sup>2</sup> S.L Education Institute, Moradabad (UP).

$$\left( \hat{C} = \sum_i \alpha_i C(p^i), \hat{\pi} = \sum_i \alpha_i p^i \right),$$

where  $\hat{\pi} \in \text{conv } Q$ . This is the underlying reason why we in our next result we cannot handle the “bundle compression” strategy.

**Theorem:** Suppose the primal problem

$$\begin{cases} \max_p C(p) \\ p \in Q \subset \mathbb{R}^p \\ g_j(p) \leq 0, j \in L := \{1, \dots, n\}, \end{cases} \quad \dots (2)$$

satisfies either,

$$\text{for all } d \geq 0 \quad \inf_{p \in Q} \langle g(p), d \rangle \leq 0. \quad \dots (3)$$

$$\text{or } \sum_{i \leq r} \tilde{\alpha}_i g_j(\tilde{p}^i) \text{ for all } j = 1, \dots, n \quad \dots (4)$$

with  $g$  affine,  $\text{conv } Q$  compact, and a dual function of the form (1). Consider Algorithm applied to the minimization problem

$$\min_{x \geq 0} f(x), \text{ where } f(x) := \max_{p \in Q} \left\{ C(p) - \sum_{j \in L} g_j(p) x_j \right\} \quad \dots (5)$$

with separation procedure satisfying,  $g_l(p) \leq 0$ . Suppose  $\text{tol} = 0$  and that Step 5 of the algorithm (Choose a reduced bundle  $B_{\text{red}}$ ; Define  $B_{l+1} := B_{\text{red}} \cup \{(C_l, p^l)\}$ ), always sets the bundle management strategy to be either “no bundle deletion” or “bundle selection”. If at null steps  $\mu_l = \mu_{k(l)}$ , while at serious steps  $\mu_{l_k} \leq \mu_{\max}$ , then the algorithm stops after a finite number of iterations having found a primal convex point  $\hat{\pi}^{\text{last}}$ , solution to  $\text{conv } (1)$ , with  $x^{\text{last}}$  solving (5).

**Proof.** Suppose that there is a last serious step  $\hat{x}$  followed by infinitely many null steps and let  $\hat{\mu}$  denote the corresponding proximal parameter. Note first that, since  $(C(p^l), p^l) \in B_{l+1}$  for any bundle management strategy, having  $x^{l+1} = x^l$  implies that  $f(x^{l+1}) = f(x^l) = C(p^l) - \langle g(p^l), x^{l+1} \rangle$ . But since by construction  $\tilde{f} \leq f$  and  $\tilde{f}_{l+1}(x^{l+1}) \geq C(p^l) - \langle g(p^l), x^{l+1} \rangle$ , we conclude that  $\tilde{f}_{l+1}(x^{l+1}) = f(x^{l+1})$  and, hence,  $\Delta_{l+1} = f(\hat{x}) - f(x^{l+1})$ .

By  $f(x^{l+1}) + \frac{1}{2}\hat{\mu}|x^{l+1} - \hat{x}|^2 = \check{f}_{l+1}(x^{l+1}) + \frac{1}{2}\hat{\mu}|x^{l+1} - \hat{x}|^2 \leq f(\hat{x}) \leq f(x^{l+1})$ , so  $\hat{x} = x^{l+1}$ . In this case the algorithm would eventually stop ( $\Delta_{l+1} = 0$ , contradicting our starting assumption. Thus, infinite null steps occur only with  $x^{l+1} \neq x^l$ . For  $l \geq \text{last}$ , consider the following problem :

$$\begin{cases} \min_{r \in \mathbb{R}, x \in \mathbb{R}^n} r + \frac{1}{2}\hat{\mu}|x - \hat{x}|^2 \\ r \geq C(p^i) - \langle g(p^i), x \rangle \text{ for } i \in B_l \\ x_{\bar{j}} \geq 0 \text{ and } x_{L \setminus \bar{j}} = 0, \end{cases} \quad \dots (6)$$

and denote its optimal value  $O_l := \check{f}_l(x^l) + \frac{1}{2}\hat{\mu}|x^l - \hat{x}|^2$ . Relation in [HUL93]

$$O_{l+1} \geq O_l + \frac{1}{2}\hat{\mu}|x^{l+1} - x^l|^2,$$

together with the fact that  $x^{l+1} \neq x^l$  imply that the values of  $O_l$  are strictly increasing. The assumption that  $Q$  is finite implies that  $B_l$  contains at most  $q$  different pairs  $(C_i, p^i)$ . As a result, there is a finite number of different feasible sets in (22) for  $l \geq \text{last}$ , contradicting the fact that the (infinite) values of  $O_l$  are strictly increasing.

Consider  $l_k \in L'$ ,  $\hat{s}^{l_k} \in \partial \check{f}_{l_k}(\hat{x}^{k+1})$ ,  $\hat{v}^{l_k} \in N_{J_{l_k}}(\hat{x}^{k+1})$ . Since  $Q$  is finite there is only a finite number of different combinations of  $J_{l_k}$  and  $Q_{l_k} := \{p^i \in Q : i \in B_{l_k}\}$ .

There exists  $\rho > 0$  such that  $|\hat{s}^{l_k} + \hat{v}^{l_k}| < \rho$  implies that  $\hat{s}^{l_k} + \hat{v}^{l_k} = 0$ . As a result, using (8),  $\hat{x}^{k+1} = x^{l_k+1} = \hat{x}^k$ . For this value of  $\hat{x}^{k+1}$ , the descent test in Step 3 of Algorithm (which must hold because  $l_k$  gave a serious step) becomes  $f(\hat{x}^k) \leq f(\hat{x}^k) - m\Delta_{l_k}$ . This inequality is only possible if  $\Delta_{l_k} = 0$ , or,  $\hat{x}^{k+1} = \hat{x}^k$ , if

$$f(\hat{x}^{k+1}) = \check{f}_{l_k}(\hat{x}^{k+1}). \quad \dots (7)$$

Let  $k'$  be the first index such that  $\hat{s}^{l_{k'}} + \hat{v}^{l_{k'}} = 0$ , i.e. such that  $\hat{x}^{k'+1}$  minimizes  $\check{f}_{l_{k'}}$  on the set  $\{x \geq 0 : x_{L \setminus J_{l_{k'}}} = 0\}$ . For every  $l \in L \setminus J_{l_{k'}}$  there is an index  $j \in J_{l_{k'}}$  such that

$$\hat{v}_i^{l_{k'}} = -\hat{s}_i^{l_{k'}} = g_i(\hat{\pi}^{l_{k'}}) \leq \beta g_j(\hat{\pi}^{l_{k'}}) = -\beta \hat{s}_j^{l_{k'}} = \beta \hat{v}_j^{l_{k'}} \leq 0,$$



so  $\hat{x}^{k'+1}$  solves the problem  $\min_{x \geq 0} \tilde{f}_{I_{k'}}(x)$  by Corollary 3.

Since  $\tilde{f} \leq f$  by construction, we see that

$$\tilde{f}_{I_{k'}}(\hat{x}^{k'+1}) \leq f(x^\infty), \quad \dots (8)$$

and by (7), this means that  $f(x^\infty) \geq f(\hat{x}^{k'+1})$ , i.e., the relation is satisfied with equality, because  $x^\infty$  solves (2). Therefore, the algorithm would have  $\Delta_{I_{k'}} = 0$  with  $I_{I_{k'}} \subseteq J_{I_{k'}}$ , and the stopping test would be activated.

## CONCLUSION

It is worth mentioning that finite termination results in the (static) bundle literature need to modify the descent test in Step 3 by setting the Armijo-like parameter  $m$  equal to 1. Such requirement is used for example in [1], and [2] to show that there can only be a finite number of serious steps when the function  $f$  is polyhedral, with the same assumptions on the bundle management strategy, i.e., either no deletion or bundle selection. Since the static case is covered by the dynamic setting, Theorem extends the known results of finite termination to include the case  $m \in (0, 1)$ .

## REFERENCES

- [1] Kiwiel K.C.. Methods of descent for nondifferentiable optimization. Springer-Verlag, Berlin, 1985.
- [2] Kiwiel K.C.. Exact penalty functions in proximal bundle methods for constrained convex nondifferentiable minimization. Math. Programming, 52(2, Ser. B):285–302, 1991.
- [3] Kiwiel K.C. Approximations in Proximal Bundle Methods and Decomposition of Convex Programs. Journal of Optimization Theory and Applications, 84:529–548, 1995.
- [4] Kiwiel K.C.. A proximal bundle method with approximate subgradient linearizations. SIAM J. Optim., 16:1007–1023, 2006.
- [5] Lucena A. and Beasley J. E.. Branch and cut algorithms. In Advances in linear and integer programming, volume 4 of Oxford Lecture Ser. Math. Appl., pages 187–221. Oxford Univ. Press, New York, 1996.
- [6] Lemaréchal C., Nemirovskii A., and Nesterov Yu.. New variants of bundle methods. Math. Program., 69:111–148, 1995.
- [7] Lucena A.. Steiner problem in graphs: Lagrangean relaxation and cutting-planes. COAL Bulletin, 21(2):2–8, 1992. san and J. VI.
- [8] Luk.cek L.. A bundle-Newton method for nonsmooth unconstrained minimization. Math. Programming, 83(3, Ser. A):373–391, 1998.

# Solvent Effect on Electronic Absorption Spectra of 2, 5-Dimethoxy Thio Phenol

PRADEEP KUMAR<sup>1</sup> AND HARISH BHATIA<sup>1</sup>

## Abstract

*The electronic absorption spectra of 2,5-dimethoxy thio phenol has been recorded in the region 2000-3500Å. The electronic absorption spectra has been recorded in various solvents (viz. ethanol, methanol and water). The effect of substituents has been discussed. The effect of pH variation in ethanol solvent is also studied and discussed.*

*Keywords: Electronic Absorption Spectra, pH Effect and Solvent Effect*

## INTRODUCTION

Spectroscopic studies of phenol and its derivatives received considerable attention in the recent years [1–3]. The studies of phenol derivatives have become quite interesting because they are the constituents of DNA & RNA and hence play a central role in the structure and properties of the nucleic acids. Also phenol derivatives like chlorophenol, aminophenol and marceptophenol etc. are widely used as drugs in certain diseases. Phenol and its derivative are extensively used as a solvent as a synthetic intermediate in analytical chemistry. So, the knowledge of the molecular structure, physio-chemistry properties and vibrational properties of phenol and its derivatives is helpful for a better understanding of their function in several biological processes and analysis of the complex systems. Rao [4] have shown that the phenol molecule has planer structure in the ground state and a quasi planer one in the excited state.

The absorption spectra of phenol and its derivatives have been predicted theoretically and practically by various workers [5,6] have found the evidence of the electronic transitions as  $n - \pi^*$ , and  $n - \sigma^*$ . This the detailed study of the electronic transitions of substituted phenols is of importance in order to check the presence of  $n - \pi^*$ ,  $\pi - \pi^*$ , and  $n - \sigma^*$ . Thus the detailed study of the electronic transitions of substituted phenols is of importance in order to check the presence of  $n - \pi^*$ ,  $\pi - \pi^*$  and  $n - \sigma^*$  transition [7,8].

In view of the above discussion, the ultraviolet spectra in different solvents (viz., ethanol methanol and water) of the 2,5–dimethoxy thio phenol is reported and discussed [5,9].

## EXPERIMENTAL DETAILS

98% spec-pure grade sample of 2,5–dimethoxy thio phenol (abbreviated as 2,5–DMTP) was obtained from M/s Sigma Aldrich Chemic, West Germany and used as such without further

---

<sup>1</sup> Molecular Spectroscopy and Biophysics Lab. Deptt. of Physics, D.N. College, Meertu

purification. However, their purity was confirmed by elemental analysis and melting point determination [120–124°]. The experimental technique in the ultraviolet spectra of 2,5–DMTP was recorded on Beckman Spectrophotometer model–35 in the region 2000–3500Å. The spectra have been recorded in various solvents (viz. ethanol, methanol and water). The concentration of the solution in all the cases was kept constant ( $8 \times 10^{-3}$  gm/liter). All the solvents used was of spectroscopic grade. The ratio of pure solvent was obtained at 9:1 by volume.

## RESULTS AND DISCUSSION

The molecular structure of 2,5–dimethoxy thio phenol is given in Fig. 1.

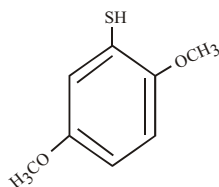

**Fig. 1:** Molecular Structure of 2,5–DMTP

The observed ultraviolet bands of said molecule are given in Table–1. The ultraviolet absorption spectra of the said compound in different solvents (viz. ethanol, methanol and water) are shown in Fig. 2 and Fig. 3.

## ELECTRONIC SPECTRA

Some investigator [10-13] have suggested, in phenol the introduction of –OH group replaced of H atom in benzene, exhibits a red shift in  $\pi - \pi^*$  and  $n - \sigma^*$  transition and blue shift in  $n - \pi^*$  transition. In the present study, the UV spectra of the molecule 2,5–DMTP was recorded in different solvents (viz. ethanol methanol and water) but the band system which corresponds to  ${}^1A \longrightarrow {}^1U$  transitions  $n - \pi^*$  has been observed between 2950–3100Å. The band system, which corresponds to  ${}^1A_{1g} \longrightarrow {}^1B_{2u}$  transition ( $\pi - \pi^*$ ) has been observed between 2300–2500Å for the molecule 2,3–dihydroxy pyridine, while the band system which corresponds to  ${}^1A_{1g} \longrightarrow {}^1B_{2u}$  transition has been observed between 2000–2100Å for the molecule 2,3–dihydroxy benzaldehyde.

In view of this, the  $n - \pi^*$  Transition observed at 2960Å in 2,5–DMTP is taken to represent out-of-plane transition, while  $\pi - \pi^*$  and  $n - \pi^*$  transition around 2240 and 2070Å in-plane transition originated from  $A_{1g} \longrightarrow B_{2u}$  transition respectively. In which the later one derives from  $A_1 \longrightarrow B_1$  transitions [14,15].

## Solvent Effect

The electronic spectra of a molecule when recorded in a solvent generally shift the band in comparison to those obtained in the vapour phase. This is called the solvents shift effect and is due to the weak physical interaction between solute and solvents atoms. This interactions may be generally classified into specific and non-specific solvents effect on the electronic state of solute. Specific solvents effects include ionisation charge transfer,

aggregation phenomenon and hydrogen bonding of molecule. Non-specific effect is due to the depressive induction electro-state forces that may occur between solute and the surrounding solvents molecule. Solvent polarity effects the electronic transitions and this depends on whether the solute becomes more or less polar after excitation polar solvent. This change of charge distribution in the molecule and result increases delocalization [16-18] for  $\pi - \pi^*$  transitions, both the ground and excited states are stabilized and the absorption moves towards longer wavelength. For  $n - \pi^*$  transitions, the ground state is more stabilized then the excited state and consequently absorption to the shorter wavelength.

In the present investigation, it is clearly observed that the  $n - \pi^*$  transitions around 3100 Å is blue shifted in 2,5-DMTP with increasing polarity of the solvent (ethanol → methanol → water) as shown in Table-2. It is evident that the blue shift has been observed in  $n - \pi^*$  transitions of the molecule with increasing of refractive index of the solvents [66]. A red shift has been observed in the  $\pi - \pi^*$  and  $n - \pi^*$  transitions around 2240 and 2070 Å in the 2,5-DMTP with increasing the polarity of the solvents (ethanol → methanol → water) which is identical to the trend reported for these transition in the literature value [9,11,19]. The shift is due to momentary polarization of the solvents by the transition dipole of the solute. The polarity of the solute also plays an important role in the electronic transition. In the present study the molecule 2,5-DMTP is non-polar, the shift of absorption spectra of slightly polar solute are predominantly due to the dipole-dipole interactions the solute and solvent in the ground and excited state respectively.

The hydrogen bonding will lower the energy of ground state more then that of excited state, which consequently increase the excitation energy in a blue shift. High dielectric constant leads to a higher transition energy and an emergence of a short wavelength band would be expected. During the present study in the said molecule, the shortest wavelength system 2070 Å has been observed in 2,5-DMTP [20-24].

Furthermore, the greater the polarity of the solvent, the greater the attraction between solute and solvent molecule. Thus, the system would be more stable [15]. Also with increasing dielectric constant of the solvent the ionising potentiality of the solute molecule is increased.

### Effect of pH Variation

The absorption spectra of the compound in different solvents at various pH are shown in Fig. [3] and in Table - 2. Yadav [15] suggested that in phenol, the substituent is of acidic nature like -OH, the molecule may exist in neutral, cationic or anionic form depending upon the pH of the solution, and the wavelength of the band around 3000 Å increases in the sequence neutral molecule → cation → anion [25,26].

In the present study, there is a blue shift in the position of entire band with the decrease in pH, the  $n - \pi^*$  band is reported to shifted towards shorter wavelength [70]. These are in accordance with the trend observed during the present investigation [18,27].

**Table 2:** Analysis of Electric Spectra Of 2,5–DMTP (All values are in Å)

S0Solvent	DC	RI	$n - \pi^*$	$\pi - \pi^*$	$n - \sigma^*$
Ethanol	25.0	1.3773	2960	–	–
Methanol	32.0	1.3362	2960	2240	–
Water	80.0	1.3380	2965	–	2070

Where, DC = Dielectric constant RI = Refractive index

**Table 3:** Effect of PH variation on electronic transition of 2, 5 – D M T P (All values are in Å)

Solvent	$n - \pi^*$	$\pi - \pi^*$	$n - \sigma^*$
Ethanol	2780	–	–
Ethanol + Hcl	2730	–	2080
Ethanol + NaOH	2680	2280	–

## REFERENCES

- [1] Garima Tripathi et al, *Indian J. Phy.*, 78 (12), 1377 (2004)
- [2] B.S. Yadav, M.K. Yadav, Pradeep Kumar, Israt Ali & Priti Yadav, *oriental J of Chem.* 22 (2) 447 (2006).
- [3] B. S. Yadav, Priti Yadav, Pradeep Kumar & Vaishali, *Asian J of Chem.*, 20 (1) 273 (2008).
- [4] N. Sunderaganeshan et al, *spectro chimica acta*, 70 (1) 50 (2008).
- [5] B.S. Yadav, Vipin Kumar and M.K. Yadav, *Indian J. Pure & Appl. Phys.*, 36, 557 (1998)
- [6] A. Shiraz, S. Liana and Sergio Bonara, *Spectrochimica Acta*, 68 (5) 1296 (2007).
- [7] R.A. Yadav & S.N. Thakur, *IJP & AP* 44 (1) 5 (2006).
- [8] V. Krishan Kumar et al, *Spectrochimica Acta*, 70 (1) 210 (2008).
- [9] S. Gunesakaran, S. Seshadri & S. Muthu, 44 (5) 360 (2006).
- [10] B.S. Yadav, Pradeep Kumar and Priti Yadav, *Ultra Science*, 18 (2) 187 (2006)
- [11] S. Ganesekaran & D. Uttasa, *IJP & AP*, 46 (2) 100 (2008).
- [12] V. K Rastogi et al, *IJP & AP*, 44 (9) 653 (2006).
- [13] N. sunderganeshan et al, *Spectrochimica Acta*, 65(5) 1053 (2006).
- [14] S. Ganesekaran, S. Sashadri & S. Muthu, *IJP & AP*, 44 (8) 581 (2006).
- [15] R.P. Tiwari, S.N. Thakur, R.A. Singh, *IJP & AP*, 45 (7) 569 (2008).
- [16] B. S. Yadav, S.K. Tyagi & Seema, *IJP & AP*, 44 (9) 644 (2006). (2007).
- [17] M.K. Yadav, Surbhi, & Seema, *Ultra Science*, 19 (1) 45 (2007).
- [18] F.Liakath Ali, P.Sivagurunathan, *IJP&AP*, 46 (1) 12 (2008)
- [19] H.Feki,N.Fourti, *Spectrochimica Acta*, 67 (5) 1201 (2007).
- [20] B.S.Yadav, Israt Ali, & Seema, *Ultra Science*, 19 (1) 51 (2007).
- [21] B.S.Yadav, Surbhi, Seema ,*Ultra Science* , 19 (1) 45 (2007).
- [22] S.Gunesekaran, R.Thilak Kumar & S.Ponnusamy, *IJP&AP* , 45 (6) 884 (2007).
- [23] Varsanyi, “Vibrational spectra of benzene derivatives”, (Academic Press New York (1960).
- [24] B.S.Yadav, Israt Ali, Pradeep Kumar, & Priti Yadav, *IJP & AP*, 45 (12) 979 (2007).
- [25] Tanveer Hasan , P.K.Singh, K.Singhal, *Pramana J of Physics*, 69 (4) 675 (2007).
- [26] J.S.Singh, *Pramana J of Physics*, 70 (3) 479 (2008).
- [27] M.K.Yadav and Surbhi, *IJP&AP*, 82 (1) 117 (2008).

# Removal of High Density Impulse Noise using Efficient Median Filter for Digital Image

RITU SHARMA<sup>1</sup> AND VIJAI SINGH<sup>1</sup>

## Abstract

*Image filtering strive to remove the noise from an image while retaining its perceived visual quality. Noise can be like gamma noise, Salt and pepper noise, Gaussiannoise, Consistent noise. The main objective of filtering is to remove the impulses from image to recovered the noise free image with minimum signal distortion. The most widely used and the best known non-linear digital filters are median filters, based on order statistics. Median filters are known for their ability to remove impulse noise without damaging the edges. The effective removal of impulse sometimes leads to images with blurred and distorted features. Their performance is poor at high noise densities. We have use clustering algorithm to prepare clusters of low intensity and high intensity pixels in different groups. After this we have use a filtering algorithm to significantly improve their filtering performance and enhance their output image.*

## INTRODUCTION

### Impulse Noise

Impulse noise is a category of (acoustic) noise which includes unwanted, almost instantaneous (thus impulse-like) sharp sounds (like clicks and pops). Noises of the kind are usually caused by electromagnetic interference, scratches on the recording disks, and ill synchronization in digital recording and communication. High levels of such a noise ( 200 + Decibels ) may damage internal organs, while 180 Decibels are enough to destroy or damage human ears[1].

In order to achieve robustness in pattern recognition and adaptive control systems, An impulse noise filter can be used to enhance the quality of noisy signals. At the expense of signal degradation, Median filter is a classic filter used to remove the noise. To use model-based systems, it's quite common, In order to get better performing impulse noise filters, that cognize the properties of the noise and source signal (in time or frequency), in order to remove only impulse obliterated samples.

### Image Restoration

The main motive of image restoration is to "compensate for" or "Undo" defects which degrade an image. Degradation comes in many forms such as motion blur, noise, camera misfocus.

<sup>1</sup> M.Tech Student, Dept. of CSE, IMS Engineering College, Ghaziabad (UP).

In case like motion blur, it is possible to come up with an very good estimate of the actual blurring function and “undo” the blur to restore the original image. In case where the image is corrupted by noise, the best we may hope to do is to compensate for the degradation it caused. In this project, we will implement and introduce several methods that were used in image processing world to restore images.

### **Modified K-Means**

This paper presents an approach of data clustering using Modified K-Means algorithm that is based on the improvement of the sensitivity of initial centre of clusters. This algorithm splits the whole space into different segments and calculates the frequency of data point in each segment. The segment which reveals maximum frequency of data point will have the maximum probability to contain the centroid of cluster. The number of cluster's centroid ( $k$ ) will be provided by the user in the same manner like the traditional K-mean algorithm and the number of division will be  $k \times k$  ( $k$  vertically as well as  $k$  horizontally). If the highest frequency of data point is same in different segments and the upper bound of segment crosses the threshold  $k$  then merging of different segments become mandatory and then take the highest  $k$  segment for calculating the initial centroid of clusters. In this paper we also define a threshold distance for each cluster's centroid to compare the distance between data point and cluster's centroid with this threshold distance through which we can minimize the computational effort during calculation of distance between data point and cluster's centroid. It is shown that how the modified k-mean algorithm will decrease the complexity & the effort of numerical calculation, maintaining the easiness of implementing the k-mean algorithm. It assigns the data point to their appropriate class or cluster more effectively [2,3]. We have presented a modified k-means algorithm which eliminates the problem of generation of empty clusters (with some exceptions). Here, the basic structure of the original k-means is preserved along with all its necessary characteristics. A new centre vector computation strategy enables us to redefine the clustering process and to reach our goal. The modified algorithm is found to work very satisfactorily, with some conditional exceptions which are very rare in practice [4].

### **MODIFIED APPROACH K-MEAN ALGORITHM:**

The K-mean algorithm is a popular clustering algorithm and has its application in data mining, image segmentation, bioinformatics and many other fields. This algorithm works well with small datasets. In this paper we proposed an algorithm that works well with large datasets. Modified k-mean algorithm avoids getting into locally optimal solution in some degree, and reduces the adoption of cluster -error criterion [5].

Algorithm: Modified approach ( $S, k$ ),  $S = \{x_1, x_2, \dots, x_n\}$

Input: The number of clusters  $k_1$  ( $k_1 > k$ ) and a dataset containing  $n$  objects ( $X_{ij}$ ).

Output: A set of  $k$  clusters ( $C_{ij}$ ) that minimize the Cluster - error criterion.

### **Algorithm**

1. Compute the distance between each data point and all other data- points in the set  $D$ .

2. Find the closest pair of data points from the set  $D$  and form a data-point set  $A_m$  ( $1 \leq p \leq k+1$ ) which contains these two data-points, Delete these two data points from the set  $D$
3. Find the data point in  $D$  that is closest to the data point set  $A_p$ , Add it to  $A_p$  and delete it from  $D$
4. Repeat step 4 until the number of data points in  $A_m$  reaches  $(n/k)$
5. If  $p < k+1$ , then  $p = p+1$ , find another pair of data points from  $D$  between which the distance is the shortest, form another data-point set  $A_p$  and delete them from  $D$ , Go to step 4.

#### **Algorithm A**

- For each data-point set  $A_m$  ( $1 \leq p \leq k$ ) find the arithmetic mean of the vectors of data points  $C_p$  ( $1 \leq p \leq k$ ) in  $A_p$ .
- Select nearest object of each  $C_p$  ( $1 \leq p \leq k$ ) as initial centroid.
- Compute the distance of each data-point  $d_i$  ( $1 \leq i \leq n$ ) to all the centroids  $c_j$  ( $1 \leq j \leq k+1$ ) as  $d(d_i, c_j)$
- For each data-point  $d_i$ , find the closest centroid  $c_j$  and assign  $d_i$  to cluster  $j$
- Set  $\text{ClusterId}[i]=j$ ; //  $j$ :Id of the closest cluster
- Set  $\text{Nearest\_Dist}[i]=d(d_i, c_j)$
- For each cluster  $j$  ( $1 \leq j \leq k$ ), recalculate the centroids
- Repeat

#### **Algorithm B**

1. For each data-point  $d_i$ 
  - Compute its distance from the centroid of the present nearest cluster
  - If this distance is less than or equal to the present nearest distance, the data-point stays in the cluster
  - Else ;
  - For every centroid  $c_j$  ( $1 \leq j \leq k$ ) Compute the distance  $(d_i, c_j)$ ; Endfor
  - Assign the data-point  $d_i$  to the cluster with the nearest centroid  $C_j$
  - Set  $\text{ClusterId}[i]=j$
  - Set  $\text{Nearest\_Dist}[i]=d(d_i, c_j)$ ; Endfor

#### **OR Modified K-Means Algorithm**

**Input:** a set  $D$  of  $d$ -dimensional data and an integer  $K$ .

**Output:**  $K$  clusters

**begin**

randomly pick  $K$  points  $D$  to be initial means;

**while** measure  $M$  is not stable **do**

**begin**



compute distance  $dkj = \|\mathbf{x}_j - \mathbf{z}_k\|_2$  for each  
 $k, j$  where  $1 \leq k \leq K$  and  $1 \leq j \leq N$ , and  
 determine members of new  $K$  subsets based  
 upon minimum distance to  $\mathbf{z}_k$  for  $1 \leq k \leq K$ ;  
 compute new center  $\mathbf{z}_k$  for  $1 \leq k \leq K$  using (3);  
 compute  $M$ ;  
**end**  
**end**

### Type-2 Fuzzy System

The original fuzzy logic (FL), Type-1 FL, cannot handle (that is, model and minimize the effects of) uncertainties sounds paradoxical because the word fuzzy has the connotation of uncertainty. A user believes that Type-1 FL captures the uncertainties and vagueness. But, in reality Type-1 FL handles only the vagueness, not uncertainties, by using precise membership functions (MFs). When the Type-1 MFs have been chosen, all uncertainty disappears because Type-1 MFs are totally precise. Type-2 FL, on the other hand, handles uncertainties hidden in the information/data as well as vagueness by modeling these using Type-2 MFs. All set theoretic operations, such as union, intersection, and complement for Type-1 fuzzy sets, can be performed in the same for Type-2 fuzzy sets. Procedures for how to do this have been worked out and are especially simple for Type-2 fuzzy sets [Karnik'2001].

First, let's recall that FL is all about IF-THEN rules (i.e., IF the sky is blue and the temperature is between 60 and 75° Fahrenheit, THEN it is a lovely day). The IF and THEN parts of a rule are called its antecedent and consequent, and they are modeled as fuzzy sets. Rules are described by the MFs of these fuzzy sets. In Type-1 FL, the antecedents and consequents are all described by the MFs of Type-1 fuzzy sets. In Type-2 FL, some or all of the antecedents and consequents are described by the MFs of Type-2 fuzzy sets.

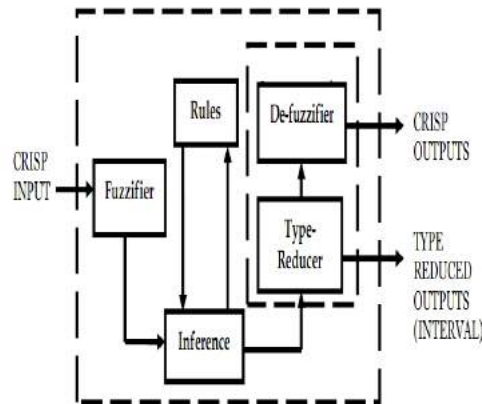

**Fig. 1:** Block Diagram of Type-2 FIS

The Type-2 fuzzy sets are three-dimensional, so they can be visualized as three-dimensional plots. Unfortunately, it is not as easy to sketch such plots as it is to sketch the two dimensional plots of a Type-1 MFs. Another way to visualize Type-2 fuzzy sets is to plot their so-called Footprint of Uncertainty (FOU). The Type-2 MFs,  $MF(x, w)$ , sits atop two-dimensional  $x-w$  plane. It sits only on the permissible (sometimes called “admissible”) values of  $x$  and  $w$ . This means that  $x$  is defined over a range of values (its domain)—say,  $X$ . In addition,  $w$  is defined over its range of values (its domain)—say,  $W$ .

From the Figure 1, the measured (crisp) inputs are first transformed into fuzzy sets in the fuzzifier block because it is fuzzy set, not the number, that activates the rules which are described in terms of fuzzy sets.

Three types of fuzzifiers are possible in an interval Type-2 FLS. When measurements are:

- Perfect, they are modeled as a crisp set;
- Noisy, but the noise is stationary, they are modeled as a Type-1 fuzzy set; and,
- Noisy, but the noise is non-stationary, they are modeled as an interval Type-2 fuzzy set (this latter kind of fuzzification cannot be done in a Type-1 FLS).

afterfuzzification of measurements (inputs), the resulting input fuzzy sets are mapped into fuzzy output sets by the Inference block. This is accomplished by first quantifying each rule using fuzzy set theory, and by then using the mathematics of fuzzy sets to establish the output of each rule, with the help of an inference mechanism. If there are  $M$  rules, the fuzzy input sets to the Inference block will activate only a subset of those rules usually fewer than  $M$  rules. So, at the output of the Inference block, there will be one or more fired-rule fuzzy output sets.

The fired-rule output fuzzy sets have to be converted into a number by Output Processing block as shown in the Figure 2. Conversion of an interval Type-2 fuzzy set to a number (usually) requires two steps. In the first step, an interval Type-2 fuzzy set is reduced to an interval-valued Type-1 fuzzy set called type-reduction. There are many type-reduction methods available [Karnik’2001]. Karnik and Mendel have developed an algorithm, known as the KM Algorithm, used for type-reduction. It is very fast algorithm but iterative. The second step of output processing, after type-reduction, is defuzzification. Since a type-reduced set of an interval Type-1 fuzzy set is a finite interval of numbers, the defuzzified value is just the average of the two end-points of this interval. If a type-reduced set of an interval Type-2 fuzzy set is a Type-1 fuzzy set, the defuzzified value can be obtain by any of the defuzzification method applied to Type-1 FL.

## RELATED WORK

**An Improved Modified Decision Based Filter to Remove High Density Impulse Noise [01]**, Image filtering attempts to remove the noise from an image while maintaining its perceived visual quality. Noise can be consistent noise, Gaussian noise, salt and pepper noise, gamma noise. The study concentrates on the salt and pepper noise by using improved modified decision based switching median filter. The salt and pepper noise occurs when the pixel value is either 0 or 255. The algorithm will evaluate the centre pixel’s value i.e.

whether or not it is equals to 0 and 255 If centre pixel is having value 0 or 255 then find out the alternative noise free value for the centre pixel. The quality metrics are used to evaluate the performance for image enhancement using anticipated algorithm: root mean square (RMS),bit error rate(BER). The processed pixel is checked whether it is noisy or noise free. If the processing pixel lies between maximum and minimum gray values then it is noise free pixel and remains unchanged. If the processing pixel takes maximum or minimum gray level than it is noisy pixel. Which is processed by improved decision based switching median filter using global mean for highly corrupted images. Most of the filters fail when the noise density is very high. The improved modified decision based filter works when the noise density is very high. The proposed method preserves edges than available method.

**Using Median Filter Systems for Removal of High Density Noise From Images** [04], An Efficient algorithm for median filter for removal or improvement of gray scale images that square measure highly corrupted salt and pepper noise is proposed during this paper. Noise in image square measure represent by the pixel value 0's and 255's that square measure shows that black and white dot in image. In proposed algorithm take an image and choose 3x3 size window and 5x5 size window and processing or center pixel value check if its value is 0's or 255's then image is corrupted otherwise noise free image. If image is noisy and processing pixels neighboring pixel value is between 0's and 255's then we tend to replace pixel value with the median value and if processing pixels neighboring pixel value is 0's or 255's then we tend to replace pixel value with the mean value. Further increased the window of size 5x5 and once more repeat given process until image is denoised. The proposed filter algorithm with 3x3 and 5x5 patch shows higher parametric values as compared to the standard median filter with 3x3 and 5x5 patch for Lena image. The simulation result shows higher and efficient performance of Peak signal to noise ratio and Mean Square Error and Image enhancement factor.

**Removal of High Density Salt & Pepper Noise Through Super Mean Filter for Natural Images** [06], A super-mean filter (SUMF) is proposed to remove high density salt & pepper noise from digital images. The proposed filter works in two stages, in the first stage the noisy pixels are detected and in the second stage each noisy pixel is replaced by the mean value of noise free pixel of 2x2 matrix. Extensive simulation and experimental results shows that the proposed filter works well consistently for suppressing the salt & pepper noise. The performance of proposed filter is compared with the other existing filters, standard median filter(SMF), centre weighted median filter (CWMF), progressive switching median filter (PSMF), open-close sequence filter (OCSF), decision based algorithm (DBA), modified decision based unsymmetric trimmed median filter (MDBUTMF). The proposed filter shows better performance as compared to above mentioned filters for noise removal from different gray scale images.

**Review on Improved Edge Preservation Filtering Using Gradient & Multiple Selection Based Sorted Switching Median Filter** [11], they advise a Sorted Switching Median Filter (i.e. SSMF) for successfully denoising very corrupted images while preserving the image details. The center pixel is measured as "uncorrupted" or "corrupted" noise in the detecting stage. The tarnished pixels that possess more noise-free surroundings will have higher processing priority in the SSMF sorting and filtering stages to rescue the

heavily noisy neighbors. Five noise models are considered to assess the presentation of the proposed SSMF algorithm. Several extensive simulation results conducted on both grayscale and color images with a wide range (from 10% to 90%) of noise corruption clearly show that the proposed SSMF substantially outperforms all other existing median-based filters. General Terms – Denoising, Digital image, Decision based median filter, Impulse noise, SSMF, Noise model, Salt-and-pepper noise, PSNR.

**Removal of High Density Impulse Noise through Modified Non-Linear Filter** [03], A New algorithm for the restoration of gray scale and colour images are highly corrupted by impulse noise (salt and pepper noise) is proposed in this paper. This proposed algorithm shows better results than the Standard Median Filter (SMF), Decision Based Median Filter (DBMF), Modified Decision Based Median Filter (MDBMF), Progressive Switched Median Filter (PSMF) and Modified Decision Based Unsymmetrical Trimmed Median Filter (MDBUTMF). The proposed algorithm replaces the noisy pixel by trimmed median value when other pixel values, 0's and 255's are present in the selected window and when all the pixel values are 0's and 255's then the noise pixel is replaced by increasing window size and finding trimmed mean based on algorithm. Different gray scale and colour images are tested by using the proposed algorithm and found to produce better Peak Signal to Noise Ratio (PSNR) and Image Enhancement Factor (IEF).

**A Survey on Median Filters for Removal of High Density Salt & Pepper Noise in Noisy Image** [10], Impulse noise in image is present due to bit errors in transmission or induced during the signal acquisition stage. There are two types of impulse noise, like salt and pepper noise and random valued noise. Salt and pepper noise can corrupt the images where the corrupted pixel takes either maximum or minimum gray level. Several non-linear filters have been established as reliable method to remove the salt pepper noise without damaging the edge details. Survey of non-linear Median Filters for the removal of high density salt pepper noise is presented in this paper. The basic non linear filter i.e. standard median filter (MF) and different variants such as adaptive median filters (AMF), and decision based median filters (DBMF) are described in this paper.

## **PROPOSED METHODOLOGY**

The efficient removal of impulse noise mainly depends on the detection phase. The detection method of the proposed algorithm efficiently identifies the location of noisy pixels, so that the false alarm rate and miss detection rate are minimized. Using clustering, the high intensity and low intensity noisy pixels are grouped separately. The rest of the pixels belong to the noise free group. Modified K-Means (MKM) is one of the best techniques used to cluster data. In this Proposed, MKM is incorporated in both the detection stages. For noise reduction we use type-2 fuzzy logic. The type-2 fuzzy logic based can be used to guide impulse noise removal filters to significantly improve their filtering performance and enhance their output images.

## RESULT ANALYSIS / IMPLEMENTATION

PSNR(db)		
% of Noise	Median Filter	Proposed Filter
	3x3	3x3
50	15.081	26.675
60	12.343	24.968
70	10.027	23.895
75	8.893	22.912
80	8.159	21.905
85	7.379	20.439
90	6.655	21.507

## CONCLUSION

For the removal of impulse noise, Linear and Non-Linear filters have been proposed earlier; however the removal of impulse noise often results in blurring which brings about edges being distorted and poor quality. Therefore the necessity to maintain the edge is fine details during filtering is the challenge faced by researchers today. Using clustering, the low intensity and high intensity noisy pixels are grouped separately. The rest of the pixels associate to the noise free group. Modified k-mean (MKM) is one of the best technique used to cluster data. In this proposed, MKM is incorporated in both the detection stages. For noise reduction, we use type-2 fuzzy logic. The type-2 fuzzy logic based can be used to guide impulse noise removal filters to significantly improve their filtering performance and enhance their output images.

## REFERENCES

- [1] S. Gopinathan, S. Poornima, "Image Enhancement for Impulse Noise Reduction on Images using Various Filters". International Journal of Advanced Research in Computer Science and Technology, Volume 4 No.4, April 2015.
- [2] Anurag Bhardwaj, Ashutosh Bhardwaj, "Modified K- Means Clustering Algorithm for Data Mining in Education Domain", International Journal of Advanced Research in Computer Science and Software Engineering, Volume 3, Issue 11, November 2013.
- [3] Jose, Javiar, Denail, A devisive Hierarchical K-Means based algorithm for image segmentation, IEEE 2010, pg 300-304.
- [4] Malay K. Pakhira, "A Modified k-means Algorithm to Avoid Empty Clusters", International Journal of Recent Trends in Engineering, Vol 1, No. 1, May 2009.
- [5] Anwiti Jain, Anwiti Jain, "An Efficient Modified K-Means Algorithm To Cluster Large Data-set In Data Mining", International Journal of Advanced Research in Computer Science and Electronics Engineering Volume 1, Issue 3, May 2012.
- [6] Priya Kapoor, Samandeep Singh, "An Improved Modified Decision Based Filter to Remove High Density Impulse Noise", International Journal of Advanced Research in Computer Science and Software Engineering, Volume 4, Issue 7, July 2014, ISSN: 2277 128X,
- [7] Vijayan T, "Removal of High Density Salt & Pepper Noise Using Modified Decision Based Un-Symmetric Trimmed Median Filter", International Journal of Advanced Research

- in Electrical, Electronics and Instrumentation Engineering, Vol. 2, Issue 2, February 2013, ISSN: 2278 – 8875.
- [8] T.Sunilkumar, A. Srinivas, M. Eswar Reddy AndDr. G. Ramachandra Reddy, “Removal Of High Density Impulse Noise Through Modified Non-Linear Filter”, Journal of Theoretical and Applied Information Technology, 20th January 2013. Vol. 47 No.2, E-ISSN: 1817-3195.
  - [9] Ms.Mrunali P. Mahajan, Prof. Sanjeev N Jain, “Using Median Filter Systems for Removal of High Density Noise From Images”,International Journal of Engineering Research and General Science Volume 4, Issue 1, January-February, 2016, ISSN 2091-2730.
  - [10] SorubaMarce, A.Jayachandran, G.KharmegaSundararaj, “An Efficient Algorithm For Removal Of Impulse Noise Using Adaptive Fuzzy Switching Weighted Median Filter”, International Journal of Computer Technology and Electronics Engineering (IJCTEE), Volume 2, Issue 2, ISSN 2249-6343.
  - [11] ShyamLal, Sanjeev Kumar and Mahesh Chandra, “Removal of High Density Salt & Pepper Noise Through Super Mean Filter for Natural Images”, IJCSI International Journal of Computer Science Issues, Vol. 9, Issue 3, No 3, May 2012, ISSN (Online): 1694:0814
  - [12] V.R.Vijay Kumar, S.Manikandan, D.Ebenezer, P.T.Vanathi and P.Kanagasabapathy “High Density Impulse noise Removal in Color Images Using Median Controlled Adaptive Recursive Weighted Median Filter”, International Journal of Computer Science, 34:1, IJCS\_34\_1\_2, Online Publication: : 15 August 2007.
  - [13] Hassan M. ElKamchouchi, Ahmed E. Khalil Samy H. Darwish, “Removal of High Density Impulsive Noise in Image Using Non Linear Filters” 2015 Seventh International Conference on Computational Intelligence, Modelling and Simulation, IEEE DOI 10.1109/CIMSim.2015.20
  - [14] Saravanakumar, S., A. Ebenezer Jeyakumar and K.N. Vijeyakumar, “Removal Of High Density Impulse Noise Using Morphological Based Adaptive Unsymmetrical Trimmed Mid-Point Filter”, Journal of Computer Science 10 (7): 1307-1314, 2014 ISSN: 1549-3636 © 2014 Science Publications doi:10.3844/jcssp.2014.1307.1314
  - [15] Mr.Avadhoot R. Telepatil, Prof (Dr.) S.A.Patil, Mr.VishalP.Paramane, “A Survey on Median Filters for Removal of High Density Salt & Pepper Noise in Noisy Image”, IOSR Journal of Electronics and communication Engineering (IOSR-JECE), ISSN: 2278-2834, ISBN: 2278-8735, pp: 22-26.
  - [16] Kanchan Bali, Er. PrabhpreetKaur, “Review on Improved Edge Preservation Filtering Using Gradient & Multiple Selection Based Sorted Switching Median Filter”, Kanchan Bali et al, Int.J.Computer Technology &Applications, Vol 6 May-June 2015, 490-495, ISSN:2229-6093.

# Pervasive SMS Spam Filtering: Pervasive Innovations, Methods and Data

RUBIL JAIN<sup>1</sup>, ALOK KATTIYAR<sup>2</sup> AND A.K. SONI<sup>3</sup>

## Abstract

*Pervasive computing is the next generation computing phenomena with information and communication technology everywhere for everyone for every device at all times. The security of pervasive device is beginning to catch wide attention. SMS (Short message service) [21] has become an essential communication tool used by banking government and other agencies. Its security is a very imperative issue in today's time. SMS act as source for several attacks and is not yet marked as a safe means for communication. SMS structure allows two nodes to exchange the encrypted and digitally signed SMS messages and the communication between two nodes is protected by public key cryptography and the identity justification of the associates involved in the communication is implemented in the course of ECDSA signature scheme [20]. When we send SMS from one mobile device to another device, the content in a message is pass on as unencrypted text which means that there is a possibility for the loss of information. Sometimes transmitted text contained data which is confidential like bank account number, identification key, license number and many more and it is a severe mess to send out the data via SMS until the message civility does not give encryption to the data contained in the text send via SMS prior to its transmission. Mobile or SMS spam [1] is a real and growing problem in today's era as forwarding an SMS is one of the cheapest, fastest and simple method. SMS spam filtering is a new task by which we can stop the arrival the spam messages to our phones by applying security algorithms on the network. Just like in DND [12] ( Do not disturb) we can block unwanted messages, but in future we can also try to block the messages from unwanted numbers as well as spam sources. This paper contains reviews for recent developments in SMS spam filtering and also inspires us to work on refining the SMS spam. This paper also enhances the reduction in the complexity [13] of the algorithm used and availability for furthering research in this area.*

**Keywords:** *Pervasive Computing, SMS Spam Filtering, SMS, Spam, ElGamal, SVM, HMAC, SHA, RSA*

---

<sup>1</sup> Research Scholar, M.Tech, Department of CSE, Inderprastha Engineering College, Ghaziabad, (UP)  
E-mail: rubiljain.jain292@gmail.com

<sup>2</sup> Assistant Professor, Department of CSE, Inderprastha Engineering College, Ghaziabad, (UP)  
E-mail: alok.katiyar@ipecc.org.in

<sup>3</sup> Professor, Department of CSE, Sharda University, G. Noida, (UP)  
E-mail: aksoni@rediffmail.com

## INTRODUCTION

Pervasive Spam [1] is unwanted and unnecessary/superfluous messages sent electronically via email, SMS/MMS sent chaotically to your cell phone, short code, other wireless numbers, etc. As there is a wide use of Internet in today's era, the most prevalent source of a spam is an email. Spam by a email is sent or received over the internet whereas SMS spam is typically transmitted over a mobile network. There are many reasons to use spam i.e. to push political and social agendas, to sell products and services (advertisements), and yes, to spread computer viruses and many more.

**Mobile phone spam** is a type of spam which is generally done by the text messaging or any other communication services of mobile phones or smart phone. The text messaging service [21] is exclusive as it has a maximum message of 160 characters, requires low bandwidth and provides assurance in message delivery within a particular period. In the early 2000s, as the popularity of mobile phones surged, it has been observed that frequent users of text messaging began to see an increase in the number of unsolicited or unwanted marketable advertisements which were sent to their mobile phones through text messaging. This can be troublesome for the recipient because, unlike an email, some of them may be charged a fee for every message received, which includes spam message as well. Mobile phone spam is generally less insidious than email spam. In 2010, around 90% of email is spam. The amount of mobile spam varies widely from region to region. In 2012, up to 30% of messages were spam in parts of Asia whereas in North America, mobile spam has increased rapidly from 2008-2012 but remains below 1% as of December 2012.

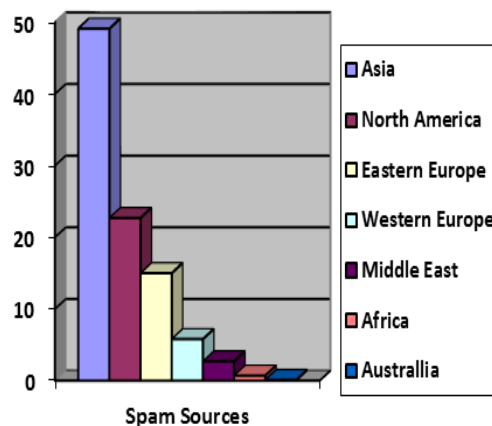

It is exposed from the recent research performed by Acision [3] that SMS is still the most widespread messaging service in the United States on comparison with other services. 61% of respondents are the owner of the Smartphone today, with 91% of this demographic seemingly using SMS regularly even with many other instant internet based messaging services on their handsets. Approx 65% of SMS users said that they need the service today and 45% of them said that they would be lost without using SMS. Therefore development of the SMS security system is very important. As per the reported statistics United State of America, South Korea, China are among the main sources of these spam correspondingly with 21.9%, 12.5%, 16.0%.



Apart from these, mobile subscribers are also facing a financial loss from SMS spam as experiencing higher network and operating costs and increased customer care costs in addition to damage to their brand and threat of regulation because users unknowingly access malicious websites and be at risk of phishing attacks or malware downloads. Many providers like AT&T Mobility [8], T-Mobile US [9], Verizon Wireless, Time Warner, U.S. Cellular, and Sprint Corporation in the US and EE, T-Mobile, Orange and O2 in the UK allow users (subscribers) to report spam by forwarding the faulty (spam) messages to short code 7726 (spells SPAM on a traditional phone keypad) (33700 in France, 1909 in India), other UK providers Vodafone and Three Mobile use 87726 and 37726 respectively. It is reported that 1/2 million spam reports in France resulted in the disconnection of 300 spammers, and many more cease orders were sent [10]. There are some spam defense measures based on detection. Also there are two developments in that area:

- A GSMA pilot spam reporting program, [11]
- The development of Open Mobile Alliance (OMA) [22] standards for mobile spam reporting. In February 2010,

This paper reviews the blockage of spam messages from our mobile phone number by filtering all the spam messages concentrating on the content based technologies by reducing the complexity of the algorithm used which help to fight against SPAM and Frauds. The rest of the paper is structured as follows: Section I discusses the type of SMS spam. Section III discusses the SMS Security Threats. Section IV discusses the overview of SMS security algorithms. Section V discusses the future aspects, Section VI discusses the results and analysis and the paper then finally concludes in Section VII with future aspects.

## TYPES OF SMS SPAM

On comparing the clusters to the types of spam identified by theGSMA [16] . We find a close correspondence to the three main types which are described as:

- (i) *SMS spam*, where unwanted text messages are sent to subscribers for mass advertising and to push social/political agendas.
- (ii) *Premium rate fraud*, which is sending unwelcome text messages that trick subscribers into calling best rate numbers or signing up for subscription services that are charged to their bill.
- (iii) *Phishing/smishing* which is sending unwanted text messages asking subscribers to call certain numbers to steal private information, which is then used for other purposes.

After performing the cluster experiment on dataset, we have observed that the most common type is premium rate fraud, which includes the clusters claims, prizes, voicemail, dating, and chat, and accounts for 43.9% of the messages. The ringtones and competitions clusters can be categorized as SMS spam and account for 32.4% of the messages whereas phishing attacks, which correspond to the services and finance clusters, account for 13.0% of the messages.

By the GSMA [15], Value Added Service provider (VASP) abuse is also identified as a distinct type of SMS spam in which unwanted messages sent to subscribers from services providers for marketing purposes but not in sufficient volumes to appear in the clustering experiment.

**Table 1:** Size and Spam Recall Result for Each Cluster

<i>Cluster name</i>	<i>Size</i>	<i>Spam recall %</i>
Ringtones	237	91.1
Claims	207	97.5
Competitions	202	96.0
Prizes	171	99.4
Voicemail	128	96.9
Dating	123	97.6
Services	102	97.1
Finance	74	98.7
Chat	65	87.7

## PERVASIVE SMS SECURITY THREATS

There are two important aspects for an individual using consumer technologies such as SMS for business purposes:

- (a) SMS is not a protected environment
- (b) Security breaches can easily occur if we focus more on people rather than technology.

In the pervasive environment network operator's systems can easily see the contents of SMS messages. Therefore, for secure communications, SMS is not suitable technology. For many users, it is hard to become conscious that how easily message can be capture. Many security gaps can be left by the underlying specifications and technology for SMS transmission. To get hold of the content of SMS messages, it would likely to be a relatively complex to hack into a telecom provider's system, but to disclose the contents is much easier by finding staff privileged to look at SMS messages.

Data security has at least four important requirements to meet as listed: [14]

- *Secrecy*: Also known as confidentiality. It is the effect of keeping illegal parties from accessing secretive information. Interception is the typical direct attack on secrecy.
- *Availability*: It is the fact of being able to access information when needed and the prevention of illegal parties from withholding access to information. Initiation and denial of service are the attacks over availability.
- *Authenticity*: Prevents that unofficial parties can change the content of message or place random messages in the network.
- *Integrity*: It is preventing anybody other that official parties from modifying the computer system assets like writing, changing status and deleting and creating

files. Among the methods of attacking integrity we found modification, replay and reordering of messages

*Types of security attacks in pervasive environment:*

- *Message Disclosure:* In the SMS service message is transmitted as an unencrypted text. Message could be intercepted during transmission. SMS is first stored as an unencrypted text in the SMSC and then delivered to the destination receiver. This message could be viewed by the users in the SMSC. AES encryption approach secure the transmitted SMS from Message Disclosure attack.
- *Replay Attack:* The attacker can mishandle the already transmitted message between the user and network. The exclusive timestamp values can secure the message from the Replay Attack.
- *Man-in-the-middle Attack:* When the user does not validate the network then the attacker can use a different BTS with the same mobile network Id and then man-in-the-middle attack is perform. This attack can be prevented by the AES algorithm.
- *Denial of Service:* Denial of Service attack is performing when sending repeatedly messages to the destination mobile phone.
- *SMS (Short Message Service) Viruses:* There have been no reports of viruses with message when the message is transfer from one mobile device to another but mobile devices are getting more powerful and programmable. The SMS viruses being spread through the message.

## OVERVIEW OF SMS SECURITY ALGORITHMS

Nowadays, mobile phone is becoming an essential requirement. Therefore, it is necessary to provide mobile phone users a secure and private communication in their daily usage of their mobiles. Securing voice calls is a tough task as it can be tabbed/recorded in transmission through various means. On the other hand, it would be very helpful to secure communication through the popularly used means, namely text messages. To develop this security system we need to first understand Hash functions, ElGamal, RSA, and SVM.

- *Secure hash algorithm:* National institute of Standards and Technology (NIST) as a U.S. Federal Information Processing Standard (FIPS) has published that the Secure Hash Algorithms is a family of cryptographic hash functions which are common and critical cryptographic primitives. Their primary application is combined use with public-key cryptosystems in digital signature schemes. The most well-known functions are SHA-1 (Secure Hash Algorithm- 1) and MD5 (Message Digest) [19]. These two hash functions are widely known for being used in the Keyed- Hash Message Authentication Code (HMAC), which is met in several communication applications, to address authentication issues.
  - SHA0: This is a retronym applied to the original version of the 160bit hash function published in 1993 under the name “SHA” which was introverted shortly after publication due to an unidentified “significant law” and replaced by the slightly revised version SHA1.

- SHA1: To be part of the Digital Signature Algorithm (DSA), it was designed by the National Security Agency (NSA) i.e. a 160bit hash function which resembles the earlier MD5 algorithm. Cryptographic weaknesses were discovered in SHA1, and the standard was no longer approved for most cryptographic uses after 2010.
- SHA2: It is a family of two similar hash functions, with different block sizes, known as SHA256 and SHA512.
- *ElGamal*: ElGamal system is a public-key cryptosystem based on the discrete logarithm problem. It consists of both encryption and signature algorithms. The encryption algorithm is similar in nature to the Diffie-Hellman key agreement protocol. The ElGamal signature algorithm is similar to the encryption algorithm in that the public key and private key have the same form, however, encryption is not the same as signature verification, nor is decryption the same as signature creation as in RSA. DSA is based in part on the ElGamal signature algorithm [18]. Study based on the best available algorithms for both factoring and discrete logarithms shows that RSA and ElGamal have similar security for equivalent key lengths.
- *RSA (Rivest-Shamir-Adleman)*: RSA Algorithm is one of the most challenging algorithms. This algorithm is developed by the Ron Rivest, Adi Shamir, and Len Adleman in 1977. RSA signature scheme is a deterministic digital signature scheme which facilitates message verification and recovery. The key size of RSA algorithm is larger than Elliptic curve cryptography. Digital signature plays an important role in online communication. In these days most of the electronic documents are acknowledged by the digital signature only. Message digest algorithm is used to generate message digest of a given input message. Message digest is also called hash code or finger print of the input message [17]. The RSA algorithm consists of the prime number and the product of the prime number forms the encryption key. This encryption is used to secure the data in the system [23]. In this algorithm message is encrypted using asymmetric encryption cipher. This algorithm consists of the large exponent and the efficiency is also large [24].
- **Support vector machines (SVMs)** are a relatively new approach that has rapidly gained popularity because of the very fast and accurate results they have achieved in a wide variety of machine learning problems. Support vector machine algorithms divide the  $n$  dimensional space represented data into two regions using a hyper plane. This hyper plane always maximizes the margin between the two regions (classes). The margin is defined by the longest distance between the examples of the two classes and is computed based on the distance between the closest instances of both classes to the margin, which are called supporting vectors. Support Vector Machines is also a supervised learning method for automatic pattern recognition.

## FUTURE ASPECTS

Deals with the design approach in pervasive environment to create an application which takes into consideration all the security issues in an SMS. In spite of the fact that instant messengers have come in place SMS are still used. Thus we need something to protect our

SMS, identify if the sender is authentic or not, to provide our SMS with a digital signature and to check if the SMS is a spam SMS. This is all done by using HMAC-Hash Message Authentication Code, by using SHA-1, SHA-256, SHA-384, SHA-512, MD-5 and MD-2 for user authentication, ElGamal for encryption and decryption, RSA with MD-5 for Digital signature, and SVM-Support Vector Machine to check if the SMS is spam or not.

This prototype is very secured in all the aspects of security as it also includes high encryption security which is used while sending and receiving the messages. Identification of spam is done using SVM classifier and the best available options for security are combined together to provide ultimate protection.

Firstly, the user will be asked to enter his/her user identity number (i.e. phone number) then he/she will be asked to enter a message, the message at one end which is going to be sent by the sender and at the other end which is going to be received by the receiver. High end to end encryption as well as decryption is performed during the sending-receiving phase respectively. When a message is received then it would be classified as spam or not spam.

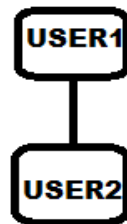

**Figure 1:** User 1 Send a Message to User 2

These methods are capable for handling the four security issues. Firstly, the use of RSA-Algorithm along with MD-5 is to check the authenticity of the user, only the senders marked by the receiver are considered authentic while the unmarked ones are considered unauthentic. The different values  $p$  and  $q$  are assigned to each user, and then to prevent spoofing attack the user is classified. To encrypt the sent message and to decrypt the received message, the ElGamal technique is used.

After this, the similarity of the data in sent and received message is checked. We have two algorithms i.e. secure hashing algorithm and message digest algorithm to check whether the sent and received message are same or not. Some of the algorithms which come under secure hashing algorithm and messaging digest algorithm are SHA-1, SHA-2, SHA-256, SHA-384, SHA-512, MD-2, MD-5. According to requirement, it depends on a user to choose an appropriate algorithm as only one algorithm can be used at a time. This is done to check if the integrity of the message is maintained or not; i.e., if the message wasn't altered during transmit.

Lastly, the received message is checked whether it is a spam or not, if the received message is found as a spam message then the user can delete it without opening that particular confidentially, and to protect the SMS from being read by any intruder in the middle, Man-in-middle attack message to protect his phone from the SMS viruses. The classification is done using support vector machine.

A vocabulary was created and then the neural network was trained first by using a message and then the received message was provided to the neural network for testing. For words stemming in the vocabulary and the message, Porter Stemming Algorithm was used. All these techniques were combined in a single module to provide a great SMS security under one roof and to reduce the time complexity by using private network channel.

## **RESULT AND ANALYSIS**

The RSA (Rivest-Shamir-Adleman) technique was considered the best security algorithm as compared by many known researchers like Alfredo De Santis, Thammi Reddy K, VenkateswaraRaoPallipamu and Er. Kumar Saurabh which is used along with the simplest and most effective and commonly used message digest MD-5.

The ELGAMAL technique is used because it is an asymmetric cryptographic algorithm which provides better result than other algorithm as per Myungsun Kim [18].

All the message digest (MD) techniques and hashing techniques are used as they all gave good results as compared by famous researchers Harris Michail, IoannisYiakoumis, Athanasios P. Kakarountas and MarkosPapadonikolakis [19]. User can choose different hashing techniques as per the set of choices provided to the user for different purpose and security level.

Support Vector Machines (SVM) technique is used in SMS Spam classification and is considered best by VinodParihar for Email spam classification.

## **CONCLUSION**

In the future business pervasive environment, Short Message Service (SMS) will play an important role, which are popularly known as m- commerce mobile banking used in governmental use as well as in daily life communication. In today's time, many business organizations use (Short Message Service) SMS for their business related purposes. High security of SMS's has become a major concern for business organizations as well as for customers.

This paper provides a work which combines every best achievable technique available to secure SMS and it is capable to authenticate message, encryption/ decryption of the message, user authentication and spam detection. By taking the obtained results into consideration from the papers studied, we are convinced to say that the collection of all the superlative techniques under one roof will provide ultimate SMS security which is MD5 with rsa for user authentication, Elgamal for encryption/decryption of the message and SVM for spam detection. By using highly secured messenger applications, end to end secure communications can be provided through SMS between the various mobile users. The study of real time secure transmission shows that this is able to restrict several types of attacks and also make use of bandwidth efficiently. To date, loads of the planned approaches are centrally based but as an alternative to server-side classifiers, SMS filtering on the user's device has an extraordinary benefit of being independent of the network and the operator's spam policy, and can filter based on the user's personal concept of what is spam. Additional technical restrictions like available processing power and the need for a programmable device are however introduced. Combinations of client side filtering and the server side filtering are also possible.

**REFERENCES**

- [1] "Spam", <http://www.kaspersky.com/about/news/spam>, 2015
- [2] Zahra S. Torabi, Mohammad H. Nadimi Shahraki, Isfahan, Iran and Akbar Nabiollahi, "Efficient Support Vector Machines for Spam Detection: A Survey", (IJCSIS) International Journal of Computer Science and Information Security, Vol. 13, No. 1, January 2015.
- [3] "Spam News", <https://en.wikipedia.org/wiki/Spam>, 2015
- [4] D. Lisonek and M. Drahansky, "SMS encryption for mobile communication", Proc. International Conference on Security Technology, SECTECH-08, Page No (198- 201),
- [5] Benevenuto, F., Magno, G., Rodrigues, T., & Almeida, V. (2010). Detecting spammers on twitter. In Proc of the 7th Annual Collaboration Electronic Messaging, Anti-Abuse and Spam Conference.
- [6] GSMA (2011b). SMS Spam and Mobile Messaging Attacks - Introduction, Trends and Examples. GSMA Spam Reporting Service.
- [7] Guzella, T. S., & Caminhas, W. M. (2009). A review of machine learning approaches to spam filtering. Expert Syst. Appl., (pp. 10206-10222).
- [8] "What YOU can do to control cell phone spam" (PDF). AT&T Consumer Guide. Retrieved 8 December 2012.
- [9] "Text Message (SMS) Spam Reporting". T-Mobile Support Community. Retrieved 8 December 2012.
- [10] "GSMA Launches SMS Spam Reporting Service - PCWorld Business Center". PC World. Retrieved 13 January 2011.
- [11] "GSMA to Address Spam and Fraudulent Messaging Threats for Consumers ~ GSM World". 2010-03-24. Retrieved 2014-07-28.
- [12] How to Activate Do Not Disturb (DND) India Registration – All Networks. May 26, 2013 by Satish Kumar.
- [13] "Time complexity of algorithms" <http://www.studytonight.com/data-structures/time-complexity-of-algorithms>
- [14] N. Saxena and A. Payal, "Enhancing Security System of Short Message Service for M-Commerce in GSM", International Journal of Computer Science & Engineering Technology (IJCSSET), ISSN: 2229-3345, vol. 2, no. 4, April 2011, pp. 126-133.
- [15] GSMA (2011a). Operator FAQs. GSMA Spam Reporting Service.
- [16] GSMA (2011b). SMS Spam and Mobile Messaging Attacks - Introduction, Trends and Examples. GSMA Spam Reporting Service.
- [17] S. Sharma, J.S. Yadav, and P. Sharma, "Modified RSA public key cryptosystem using short range natural number algorithm", international Journal, vol. 2, 2012
- [18] M. Kim, J. Kim, and J. H. Cheon, "Compress Multiple Ciphertexts using ElGamal Encryption Schemes", J. Korean Math. Soc, vol. 50, Page No (361-377), 2013.
- [19] I. Yiakoumis, M. Papadonikolakis, H. Michail and A. P. Kakarountas, "Efficient Small-Sized Implementation of the Keyed-Hash Message Authentication Code", eurocon
- [20] The Elliptic Curve Digital Signature Algorithm (ECDSA) by Don Johnson and Alfred Menezes and Scott Vanstone
- [21] SMS Tutorial: SMS Tutorial: Introduction to SMS Messaging/Short Message Service <http://www.developershome.com/sms/smsIntro.asp>
- [22] Open Mobile Alliance and 3GPP : 3GPP Project Coordination Group Meeting October 3, 2002 Open Approach to the Mobile Industry [ftp://www.3gpp.org/PCG/PCG\\_09/DOCS/PDF/PCG9\\_22.pdf](ftp://www.3gpp.org/PCG/PCG_09/DOCS/PDF/PCG9_22.pdf)
- [23] S. Sharma, J.S. Yadav, and P. Sharma, "Modified RSA public key cryptosystem using short range natural number algorithm", international Journal, vol. 2, 2012.
- [24] D. Lisonek and M. Drahansky, "SMS encryption for mobile communication", Proc. International Conference on Security Technology, 2008.

# Cost Analysis of a Complex System Under Logical and Human Errors

SHAILJA SHARMA<sup>1</sup>

## Abstract

*Several researches have contributed a lot in reliability field while analysing various complex systems mathematically, incorporating the concept of common-cause failure which may occur due to equipment design deficiency, operation and maintenance error, external environment, external catastrophe and junction deficiency etc. The author has developed a model consisting of two units in parallel redundancy which has been studied to evaluate availability and cost function under logical failure and critical human error. It has been assumed that the system remains in five states during the operational stage. Initially both the units are good, while in the state two, only one unit is good. On the other hand, states three, four and five are failed states. Logical and critical human error occur in states one and two, which cause the system to go in state three and four which are termed as failed states. Laplace-transforms of various state probabilities have been obtained which further yield time dependent probabilities by inversion process. With the help of Abel's Lamma, the long run operation of the system has also been studied. Various graphs have also been plotted to highlight the utility of the model.*

## INTRODUCTION

As the field of reliability engineering is becoming a recognized discipline in engineering, so is the awareness of its specialized topics which were generally overlooked in the past. For example, recent years common caused failures have received a widespread attention in reliability analysis of redundant components/units of system because the assumption of statistical-independent failure of redundant units is easily violated in practice. A common-cause failure is defined as any instant where multiple units of components fail due to a single cause.

In the recent past , several researches have contributed a lot in reliability field while analysing various complex systems mathematically, incorporating the concept of common-cause failure which may occur due to equipment design deficiency, operation and maintenance error, external environment, external catastrophe and junction deficiency etc.

B.S.Dhillon and H.C Viswanath presented three models with common cause failure and studied their reliability behaviour. They considered a parallel redundant system consisting of two non-identical units assuming that the system or any single unit may collapse either due to normal failure or by the common cause failure. They also assumed that repair and failure both follow exponential time distributions. The additional assumption in their

---

<sup>1</sup> Silver Oak College of Engineering and Technology  
E-mail: shailza1000@yahoo.com



analysis was that failure rate of either of the two units remains invariably the same whether it operates alone or jointly. The assumptions made by the earlier researchers were not realistic to practical situation problems as while one unit of the complex system fails, the failure rate of the other unit must increase positively due to the overloading effect. Not only this, constant repair of the unit/system leads to wastage of time cost both.

Keeping these facts in view, in this chapter, the author has developed a model consisting of two units in parallel redundancy which has been studied to evaluate availability and cost function under logical failure and critical human error. It has been assumed that the system remains in five states during the operational stage. Initially both the units are good, while in the state two, only one unit is good. On the other hand, states three, four and five are failed states. Logical and critical human error occur in states one and two, which cause the system to go in state three and four which are termed as failed states.

Laplace-transforms of various state probabilities have been obtained which further yield time dependent probabilities by inversion process. With the help of Abel's Lamma, the long run operation of the system has also been studied. Various graphs have also been plotted to highlight the utility of the model.

### ASSUMPTIONS

1. Complex system has two states: viz; good and failed.
2. Initially, the system is good.
3. The failure and repair times for the system follow exponential and general distributions respectively.
4. The system has two units in parallel where, of course, each unit has two states, good and failed.
5. In the complex system at any time only one change can take place in the state of system.
6. After repair system works like a new one and never damages anything.

### NOTATIONS

$P_0(t)$	:	Probability that at time $t$ , the system is in good state of full efficiency.
$P_1(x,t) \Delta / P_2(y,t) \Delta$	:	Probability that at time $t$ , the system is in
$/ P_3(z,t) \Delta / P_c(r,t) \Delta$	:	degraded / failed / failed / failed state and elapsed repair time lies in the interval ( $x, x + \Delta$ )( $y, y + \Delta$ )( $z, z + \Delta$ )( $r, r + \Delta$ )
$\lambda$	:	Constant failure rate from state $S_0$ to $S_1$ and $S_1$ to $S_2$
$\lambda_L$	:	Constant failure rate from state $S_0$ to $S_3$ and $S_1$ to $S_2$ .

- $\lambda_c$  : Constant failure rate from state  $S_0$  to  $S_4$  and  $S_1$  to  $S_4$ .
- $\phi_1(x)$  : General repair rate from state  $S_1$  to  $S_0$ .
- $\phi_2(y)$  : General repair rate from state  $S_2$  to  $S_0$ .
- $\phi_3(z)$  : General repair rate from state  $S_3$  to  $S_0$ .
- $\phi_4(r)$  : General repair rate from state  $S_4$  to  $S_0$ .

**FORMULATION OF MATHEMATICAL MODEL**

Viewing the nature of this system, we obtain the following set of difference-differential equations by connecting the state probabilities at time,  $t + \Delta$  with those at time  $t$ , and taking limit as  $\Delta t \rightarrow 0$ .

$$\left[ \frac{\partial}{\partial t} + 2\lambda + \lambda_L + \lambda_c \right] P_0(t) = \int_0^\infty P_1(x,t) \phi_1(x) dx + \int_0^\infty P_c(r,t) \phi_4(r) dr + \int_0^\infty P_2(y,t) \phi_2(y) dy + \int_0^\infty P_3(z,t) \phi_3(z) dz \dots (5.1)$$

$$\left[ \frac{\partial}{\partial x} + \frac{\partial}{\partial t} + \lambda_L + \lambda_c + \lambda + \phi_1(x) \right] P_1(x,t) = 0 \dots (5.2)$$

$$\left[ \frac{\partial}{\partial y} + \frac{\partial}{\partial t} + \phi_2(y) \right] P_2(y,t) = 0 \dots (5.3)$$

$$\left[ \frac{\partial}{\partial z} + \frac{\partial}{\partial t} + \phi_3(z) \right] P_3(z,t) = 0 \dots (5.4)$$

$$\left[ \frac{\partial}{\partial r} + \frac{\partial}{\partial t} + \phi_4(r) \right] P_c(r,t) = 0 \dots (5.5)$$

These equations are to be solved under the following boundary and initial conditions

**BOUNDARY CONDITIONS**

$$P_1(0,t) = 2\lambda P_0(t) \dots (5.6)$$

$$P_2(0,t) = \lambda P_1(t) \dots (5.7)$$

$$P_3(0,t) = \lambda_L [ P_0(t) + P_1(t) ] \dots (5.8)$$

$$P_c(0,t) = \lambda_c [ P_0(t) + P_1(t) ] \dots (5.9)$$

**INITIAL CONDITIONS**

$$P_0(0) = 1, \text{ otherwise zero.} \quad \dots (5.10)$$

**SOLUTION OF THE MODEL**

Taking Laplace transforms of equations (5.1) though (5.9) and solving them one by one by making use of initial conditions, we may get :

$$\begin{aligned} [s + 2\lambda + \lambda_L + \lambda_c] \bar{P}_0(s) = 1 + \int_0^\infty \bar{P}_1(x,s) \phi_1(x) dx + \int_0^\infty \bar{P}_2(y,s) \phi_2(y) dy \\ + \int_0^\infty \bar{P}_3(z,s) \phi_3(z) dz + \int_0^\infty \bar{P}_c(r,s) \phi_4(r) dr \quad \dots (5.11) \end{aligned}$$

$$\left[ \frac{\partial}{\partial x} + s + \lambda_L + \lambda + \lambda_c + \phi_1(x) \right] \bar{P}_1(x,s) = 0 \quad \dots (5.12)$$

$$\left[ \frac{\partial}{\partial y} + s + \phi_2(y) \right] \bar{P}_2(y,s) = 0 \quad \dots (5.13)$$

$$\left[ \frac{\partial}{\partial z} + s + \phi_3(z) \right] \bar{P}_3(z,s) = 0 \quad \dots (5.14)$$

$$\left[ \frac{\partial}{\partial r} + s + \phi_4(r) \right] \bar{P}_c(r,s) = 0 \quad \dots (5.15)$$

$$\bar{P}_1(0,s) = 2\lambda \bar{P}_0(s) \quad \dots (5.16)$$

$$\bar{P}_2(0,s) = \lambda \bar{P}_1(s) \quad \dots (5.17)$$

$$\bar{P}_3(0,s) = \lambda_L [\bar{P}_0(s) + \bar{P}_1(s)] \quad \dots (5.18)$$

$$\text{pW } \bar{P}_c(0,s) = \lambda_c [\bar{P}_0(s) + \bar{P}_1(s)] \quad \dots (5.19)$$

$$\text{Integrating equation (5.12) by using} \quad (5.16)$$

$$\begin{aligned} \bar{P}_1(x,s) = 2\lambda \bar{P}_0(s) e^{-(s+\lambda_L+\lambda+\lambda_c)x - \int_0^x \phi_1(x) dx} \\ \Rightarrow \bar{P}_1(s) = 2\lambda \bar{P}_0(s) D_{\phi_1}(s + \lambda_L + \lambda + \lambda_c) \quad \dots (5.20) \end{aligned}$$

$$\text{Integrating equation (5.13) by using} \quad (5.17)$$

$$\begin{aligned} \bar{P}_2(y,s) = \lambda \bar{P}_1(s) e^{-sy - \int_0^y \phi_2(y) dy} \\ \Rightarrow \bar{P}_2(s) = \lambda \bar{P}_1(s) D_{\phi_2}(s) \end{aligned}$$

$$\text{or,} \quad \bar{P}_2(s) = 2\lambda^2 \bar{P}_0(s) D_{\phi_1}(s + \lambda + \lambda_L + \lambda_c) D_{\phi_2}(s) \quad \dots (5.21)$$

$$\text{Integrating equations (5.14) and by using} \quad (5.18)$$

$$\bar{P}_3(z,s) = \lambda_L [\bar{P}_0(s) + \bar{P}_1(s)] e^{-sz - \int_0^z \phi_3(z) dz}$$

$$\Rightarrow \bar{P}_3(s) = \lambda_L [\bar{P}_0(s) + \bar{P}_1(s)] D_{\phi_3}(s)$$

$$\text{or, } \bar{P}_3(s) = \lambda_L \bar{P}_0(s) [1 + 2\lambda D_{\phi_1}(s + \lambda_L + \lambda + \lambda_c)] D_{\phi_3}(s) \quad \dots (5.22)$$

Now Integrating equations (5.15) and using (5.19)

$$\bar{P}_c(r, s) = \lambda_c [\bar{P}_0(s) + \bar{P}_1(s)] e^{-s - \int_0^r \phi_4(t) dt}$$

$$\text{or, } \bar{P}_c(s) = \lambda_c \bar{P}_0(s) [1 + 2\lambda D_{\phi_1}(s + \lambda_L + \lambda + \lambda_c)] D_{\phi_4}(s) \quad \dots (5.23)$$

Finally (5.11) gives on simplification by using relevant relations

$$\bar{P}_0(s) = \frac{1}{A(s)}$$

where,

$$\begin{aligned} A(s) = & s + 2\lambda + \lambda_L + \lambda_c - 2\lambda \bar{S}_{\phi_1}(s + \lambda_L + \lambda + \lambda_c) \\ & - 2\lambda^2 D_{\phi_1}(s + \lambda_L + \lambda + \lambda_c) \bar{S}_{\phi_2}(s) \\ & - \lambda_L [1 + 2\lambda D_{\phi_1}(s + \lambda_L + \lambda + \lambda_c)] \bar{S}_{\phi_3}(s) \\ & - \lambda_c [1 + 2\lambda D_{\phi_1}(s + \lambda_L + \lambda + \lambda_c)] \bar{S}_{\phi_4}(s) \end{aligned} \quad \dots (5.24)$$

Thus, finally we have

$$\bar{P}_0(s) = \frac{1}{A(s)} \quad \dots (5.25)$$

$$\bar{P}_1(s) = \frac{2\lambda D_{\phi_1}}{A(s)} (s + \lambda_L + \lambda + \lambda_c) \quad \dots (5.26)$$

$$\bar{P}_2(s) = \frac{2\lambda^2}{A(s)} D_{\phi_1}(s + \lambda_L + \lambda + \lambda_c) D_{\phi_2}(s) \quad \dots (5.27)$$

$$\bar{P}_3(s) = \frac{\lambda_L}{A(s)} [1 + 2\lambda D_{\phi_1}(s + \lambda_L + \lambda + \lambda_c)] D_{\phi_3}(s) \quad \dots (5.28)$$

$$\bar{P}_c(s) = \frac{\lambda_c}{A(s)} [1 + 2\lambda D_{\phi_1}(s + \lambda_L + \lambda + \lambda_c)] D_{\phi_4}(s) \quad \dots (5.29)$$

It is interesting to note that

$$\bar{P}_0(s) + \bar{P}_1(s) + \bar{P}_2(s) + \bar{P}_3(s) + \bar{P}_c(s) = \frac{1}{s} \quad \dots (5.30)$$

### ERGODIC BEHAVIOUR OF THE SYSTEM

Using Abel's Lemma viz;  $\lim_{s \rightarrow 0} s \bar{F}(s) = \lim_{t \rightarrow \infty} F(t) = F$  (say);

provided the limit on R.H.S exists, the following time independent probabilities have been obtained from equations (5.25) through (5.29)

$$P_0 = \frac{1}{A'(0)} \quad \dots (5.31)$$

$$P_1 = \frac{2\lambda}{A'(0)} D_{\phi_1}(\lambda_L + \lambda + \lambda_c) \quad \dots (5.32)$$

$$P_2 = \frac{2\lambda^2}{A'(0)} D_{\phi_1}(\lambda_L + \lambda + \lambda_c) M_{\phi_2} \quad \dots (5.33)$$

$$P_3 = \frac{\lambda_L}{A'(0)} [1 + 2\lambda D_{\phi_1}(\lambda_L + \lambda + \lambda_c)] M_{\phi_3} \quad \dots (5.34)$$

$$P_c = \frac{\lambda_c}{A'(0)} [1 + 2\lambda D_{\phi_1}(\lambda_L + \lambda + \lambda_c)] M_{\phi_4} \quad \dots (5.35)$$

where  $A'(0) = \left[ \frac{d}{ds} A(s) \right]_{s=0}$

### PARTICULAR CASES

When repair follows exponential time distribution

By setting  $\bar{S}_{\phi_1}(s + \lambda_L + \lambda + \lambda_c) = \frac{\phi_1}{s + \lambda_L + \lambda + \lambda_c + \phi_1}$

$$\bar{S}_{\phi_2}(s) = \frac{\phi_2}{s + \phi_2}, \bar{S}_{\phi_3}(s) = \frac{\phi_3}{s + \phi_3}$$

$$\bar{S}_{\phi_4}(s) = \frac{\phi_4}{s + \phi_4} \text{ in the equations (5.25) through (5.29), one may get:}$$

$$\bar{P}_0(s) = \frac{1}{E(s)} \quad \dots (5.36)$$

$$\bar{P}_1(s) = \frac{2\lambda}{E(s)} \frac{1}{s + \lambda_L + \lambda + \lambda_c + \phi_1} \quad \dots (5.37)$$

$$\bar{P}_2(s) = \frac{2\lambda}{E(s)} \frac{1}{s + \lambda_L + \lambda + \lambda_c + \phi_1} \frac{1}{s + \phi_2} \quad \dots (5.38)$$

$$\bar{P}_3(s) = \frac{\lambda_L}{E(s)} \left[ 1 + \frac{2\lambda}{s + \lambda_L + \lambda + \lambda_c + \phi_1} \right] \frac{1}{s + \phi_3} \quad \dots (5.39)$$

$$\bar{P}_c(s) = \frac{\lambda_c}{E(s)} \left[ 1 + \frac{2\lambda}{s + \lambda_L + \lambda + \lambda_C + \phi_1} \right] \frac{1}{s + \phi_4} \quad \dots (5.40)$$

where

$$E(s) = s + 2\lambda + \lambda_L + \lambda_C - \frac{2\phi_1}{s + \lambda_L + \lambda + \lambda_C + \phi_1} - \frac{2\lambda^2}{s + \lambda_L + \lambda + \lambda_C + \phi_1} \frac{\phi_2}{s + \phi_2} - \lambda_L \left[ 1 + \frac{2\lambda}{s + \lambda_L + \lambda + \lambda_C + \phi_1} \right] \frac{\phi_3}{s + \phi_3} - \lambda_C \left[ 1 + \frac{2\lambda}{s + \lambda_L + \lambda + \lambda_C + \phi_1} \right] \frac{\phi_4}{s + \phi_4} \quad \dots (5.41)$$

**EVALUATION OF UP AND DOWN STATES PROBABILITIES**

$$\bar{P}_p(s) = \bar{P}_0(s) + \bar{P}_1(s) = \frac{1}{s + 2\lambda + \lambda_L + \lambda_C} \left[ 1 + \frac{2\lambda}{s + \lambda_L + \lambda + \lambda_C} \right] \quad \dots (5.42)$$

$$\Rightarrow P_p(t) = 2e^{-(\lambda_L + \lambda + \lambda_C)t} - e^{-(2\lambda + \lambda_L + \lambda_C)t} \quad \dots (5.43)$$

and  $P_{down}(t) = 1 - P_p(t) \quad \dots (5.44)$

Also, cost function of the system is given by

$$G(t) = C_1 \left[ \frac{-2e^{-(\lambda_L + \lambda + \lambda_C)t}}{\lambda_L + \lambda + \lambda_C} + \frac{e^{-(2\lambda + \lambda_L + \lambda_C)t}}{2\lambda + \lambda_L + \lambda_C} \right]_0^t - C_2 t = C_1 \left[ \frac{-2e^{-(\lambda_L + \lambda + \lambda_C)t} + 2}{\lambda_L + \lambda + \lambda_C} + \frac{e^{-(2\lambda + \lambda_L + \lambda_C)t} - 1}{2\lambda + \lambda_L + \lambda_C} \right] - C_2 t \quad \dots (5.45)$$

where,  $C_1$  and  $C_2$  are revenue and repair cost per unit up time respectively.

**INTERPRETATION OF RESULTS**

**Availability Analysis**

- (a) According to equation (5.43), we plot a graph, given in fig. (5.2). and observe that availability of the system decreases as time t increases.
- (b) Cost Analysis According to equation (5.45), we plot a graph, shown in fig (5.3) and observe that cost function  $G(t)$  of the system increases rapidly with the increase in time 't'.

## GRAPHS

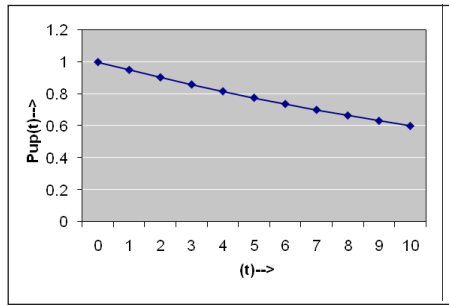
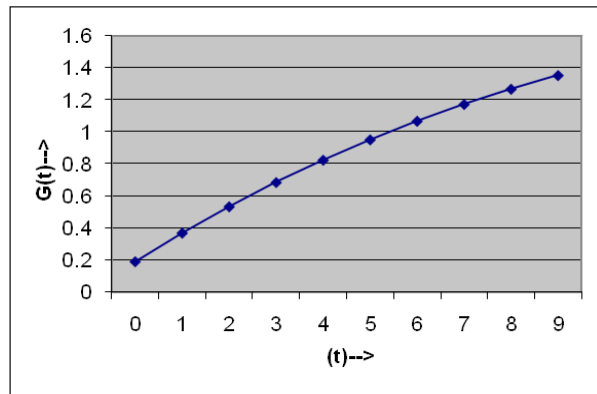

Fig 5.2



(t)	G(t)
0	0
1	0.192614
2	0.370902
3	0.535516
4	0.68708
5	0.826195
6	0.953437
7	1.069359
8	1.174491
9	1.269339
10	1.354392

Fig 5.3

## REFERENCES

- [1] Dhillon B.S. : "Quality Control, Reliability and Engineering Design", Marcel Dekker, New York, 1985.
- [2] Dhillon B.S. : "Human Reliability with Human Factors", Prog. Press Inc., New York, 1986.
- [3] Dhillon B.S. : "Reliability in Computer System Design", Intellect Books, 1987.
- [4] Dhillon B.S. : "Modeling Human Error in Repairable Systems of the Annual Reliability and Maintainability", Intellect Books, 1989.
- [5] Billinton Roy, Allan R. : "Reliability Evaluation of Engineering Systems: Concepts and Techniques", Springer Publications, 1992.
- [6] Kuo W., Prasad V.R., Tillman F.A. : "Fundamental and Applications of Reliability Optimization", Cambridge Univ. Press, Cambridge, 2000.
- [7] Gupta P.P., Agarwal S.C. : "Cost Function Analysis of Three-States Repairable System", Microelectron. Reliability, Vol.24, PP 51-53, 1984.

- [8] Dhillon B.S : “Reliability Analysis of Non-Maintained Parallel System Subject to Hardware Failure and Human Errors”, *Microelectron. Reliability*, Vol.25, PP121-122, 1985.
- [9] Gupta P.P., Agarwal S.C : “Cost Function Analysis of Three-States Repairable System”, *Microelectron. Reliability*, Vol.24, PP 51-53, 1984.
- [10] Dhillon B.S : “Reliability Analysis of Non-Maintained Parallel System Subject to Hardware Failure and Human Errors”, *Microelectron. Reliability*, Vol.25, PP121-122, 1985.
- [11] Gupta P.P., Sharma R.K. : “Evaluation of Reliability and MTTF of a Power Plant with the Aid of Boolean Function Expansion Algorithm”, *Microelectron. Reliability*, Vol.26, PP 821-824, 1986.



# An Analysis of Misclassification of Spam and Non-Spam e-mails Using Data Mining Techniques

SHRUTIKA SAINI<sup>1</sup> AND AVDHESH GUPTA<sup>2</sup>

## Abstract

*This research is to classify and channel the vast measure of information. The principle motivation behind this exploration is to lessen the error rate of the information and to enhance the accuracy. In the past methods of arrangement there might be some miss classification. In any case, in this examination the issue of misclassification is lessened. The work is exhibited by this research is a few alterations in the classification system. Thusly, it's a decent undertaking answer for filtering. This will streamline the framework execution and make a few upgrades on the past calculation. This will give the better results from the past one.*

**Keywords:** *Classification of Data, Filtering Email, Naïve Based Classifiers, Decision Tree*

## INTRODUCTION

With the proliferation of electronic mail usage as a means for personal and business communication, the volume of unwanted messages that are received is growing as well. Due to its low cost for the senders and ease of deployment, several people and companies use it to quickly distribute unsolicited bulk messages, also called spam, to a large number of recipients. The reasons for sending spam vary and may include marketing of products and services (e.g. drugs, software, and health insurance), spreading bits of gossip and other deceitful notices, (for example, profit quick), and disseminating hostile substance, (for example, grown-up material and obscene pictures). In addition, spam gives a medium to phishing assaults and circulating hurtful substance, for example, infections, Trojan stallions, worms and other malware. Spam has turned into a noteworthy risk for business clients, system managers and even conventional clients. So now the question is how good are our weapons in the spam wars? [1]

Because of the disturbing increment of the spam volume and its genuine effect, giving watchfully spam warriors has as of late pulled in significant consideration. Notwithstanding controls and enactments, a few specialized arrangements including business and open-source items have been proposed and sent to ease this issue. Installing anti-spam filters at the network gateway is among the most commonly used mechanism to block or quarantine

---

<sup>1</sup> Computer Science Department, IMS Engineering College, Ghaziabad (UP)  
E-mail: shrutika.saini@hotmail.com

<sup>2</sup> Associate Professor, IMS Engineering College, Ghaziabad (UP)  
E-mail: avdhesh.gupta@imsec.ac.in

spam messages as early as possible before they enter the users' mailboxes. Spam filtering methods fall into two broad categories which are "Learning Methods for Spam Filtering," [2]

### NON-MACHINE LEARNING BASED AND MACHINE LEARNING BASED

Most of the early anti-spam tools belonged to the former category; case in point utilizing a boycott of known spammers, a white rundown of safe senders, or a human-created rundown of watchwords, for example, "Get Rich" either in the title or the message content [3]. In any case, these static records are easy to be got around effectively by spammers; for instance by changing or mocking the sender's location or area every time. These strategies additionally require intermittent manual overhaul and the probability to sift through a honest to goodness message as spam is high which can be more genuine than not separating by any means. As per the assessments by the British Computer Society (BCS), incorrect hostile to spam arrangements might be in charge of squandering more than five million working hours a year for clients to watch that honest to goodness messages were not erroneously isolated [4].

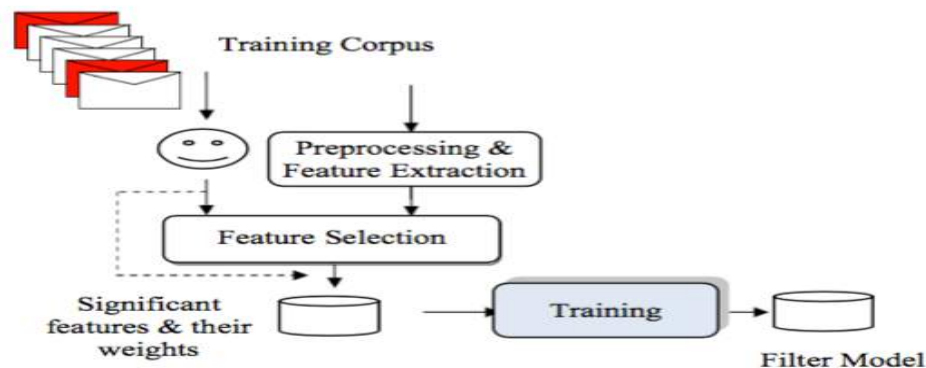

**Figure 1:** Model Construction for Spam Filtering

Unlike traditional techniques, machine learning based methods automatically analyze the content of received messages and build more robust models accordingly. Therefore, they can be more effective and dynamically updated to cope with spammers' tactics. Several machine-learning methods have been recently used for spam filtering, including support vector machines [5], memory-based learning [6], Ripper rule-based learning [7], neural networks [8], Bayesian classifiers [8, 9], fuzzy similarity [10], and additive networks [11]. With the ever-increasing sophistication of spammers' software, it has become clear that no single technique could completely solve this problem. This has led some researchers to propose the application of a myriad of different techniques at several tiers, as each may excel in some prediction aspect.

In the overall functioning of email, SMTP is also used. In shorts, the steps are:

- Client sends the message.
- Server of email contacted to email server the recipients.

- Validity of Username is checked by the email server.
- If username is valid, email is sent to the email server of the address.
- When the recipient signs in to his mailing account, he finds his email.

## **PROBLEM FORMULATION**

Choice Tree Learning is an inductive learning taking into account test learning, and originates from Concept Learning System (CLS) [9]. The most powerful choice tree calculation is ID3, proposed first time by Quinlan in [5]. Quinlan presented common (data pick up) in data hypothesis as an estimation of single property qualities for discriminant capacity, and installed the strategy for building tree into a shell of Iteration. ID3 calculation computes data entropy as heuristic capacity to assess target, receives the top-to-down arrangement which cannot be returned, and quests one a player in the entire space. It guarantees that the set up tree is the most straightforward choice tree, test information additionally the slightest. Be that as it may, it attempted to decrease the normal profundity of the tree however disregarded exploration number of takes off. So its heuristic capacity is not the most fabulous. The purpose of the paper is to find spam behavioral characteristics, so need data mining from behavior of spammers (normal mail and spam), and mail logs just met the need. Logs are the second-hand data of mail transmission in the network environment. These data include some of the characteristics of the message itself, but also some characteristics of behavior.

## **FEATURE EXTRACTOR AND SELECTION**

Before data mining, we need to analyze emails features from these email logs. We select Information Gain technology to analyze these features, to get the main feature, to omit some features with less information and weak correlation. We have to go through some analysis known as

1. **Naïve Bayes Classifier** – These are a family of simple probabilistic classifiers based on applying Bayes' theorem with strong (naive) independence assumptions between the features.
2. **Decision tree**- The data which are misclassified earlier are needed to be filtered using our method of decision tree.

## **OBJECTIVE**

The evaluation of any spam filter has traditionally borrowed heavily from the information retrieval domain. We define the measurements we have used:

**False positive rate** – represents the number of non- spam email flagged as spam divided by the total non-spam messages. This number measures the amount of normal emails flagged as spam.

**False negative rate** – represents the number of spam flagged as normal.

**Detection rate** – is the total number of spam detected divided by the total number of spam messages.

**Accurate rate** – is the total number of spam detected divided by the total number of messages.

## RESULTS

Results have been shown of various methods.

Naïve Based Gaussian Method

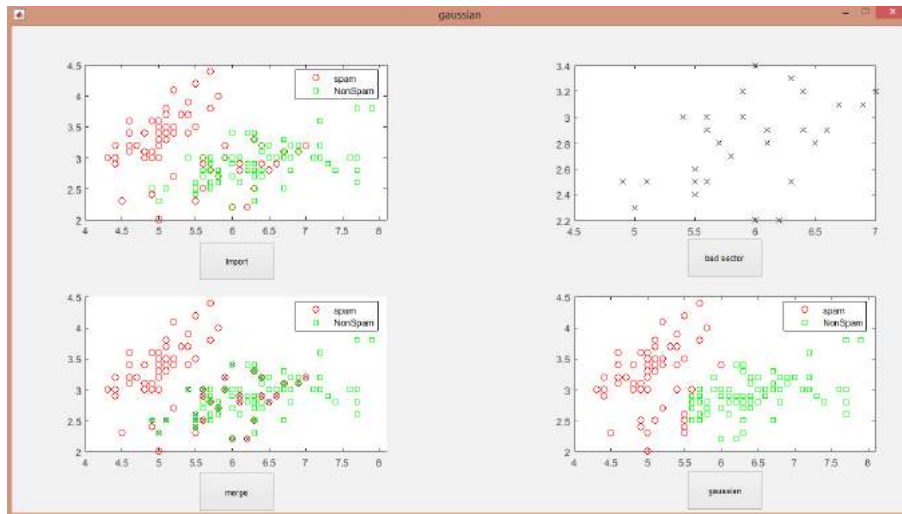

**Figure 2:** Naive Bay's Gaussian Re-substitution Error

Naïve Based Kernel Method

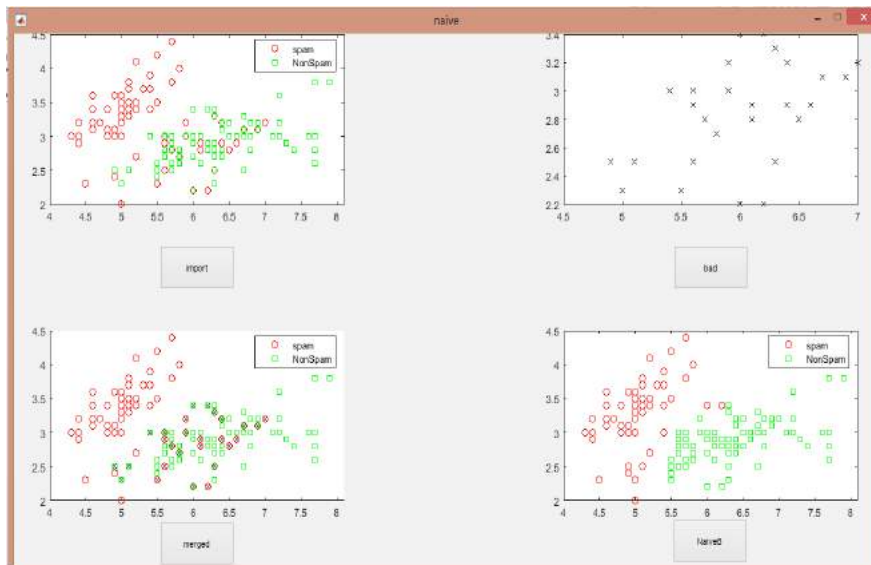

**Figure 3:** Naive Bayes Kernel Distribution Re-substitution Error Calculations

Decision Tree Method

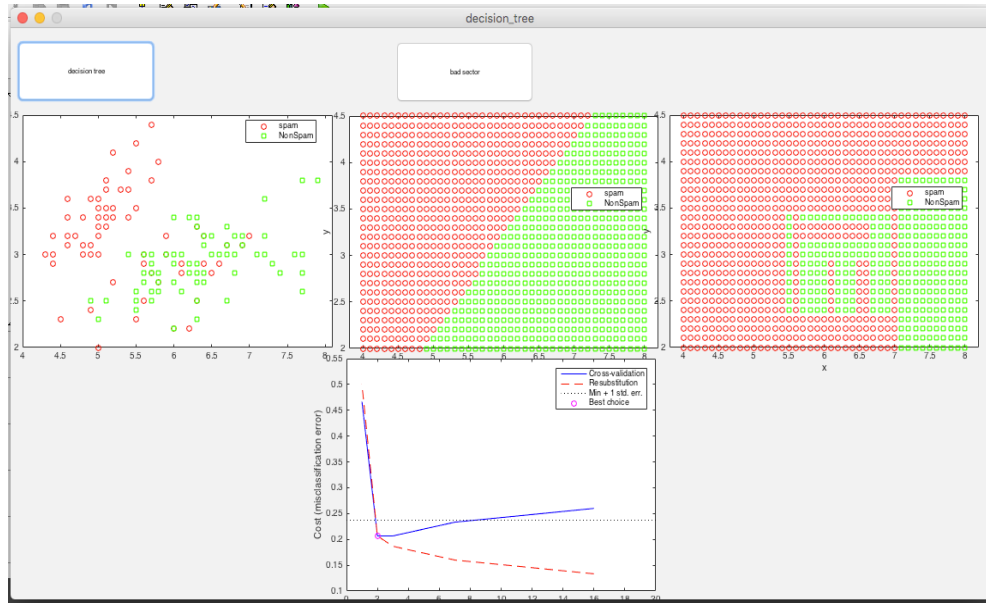

Figure 4: Use of decision Tree to find out the Cross validation Error and Best Value

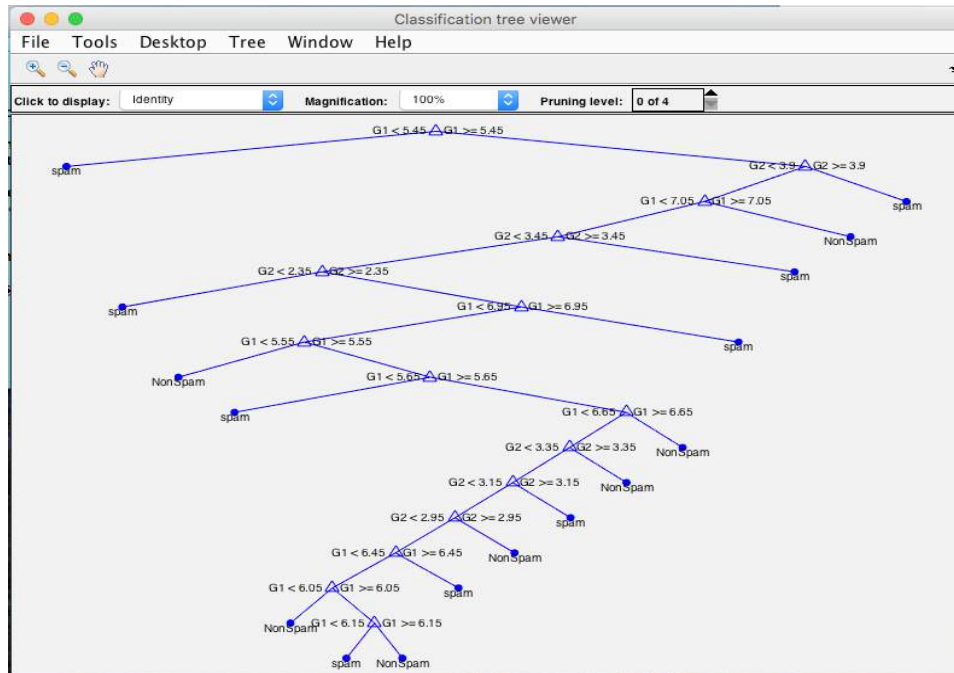
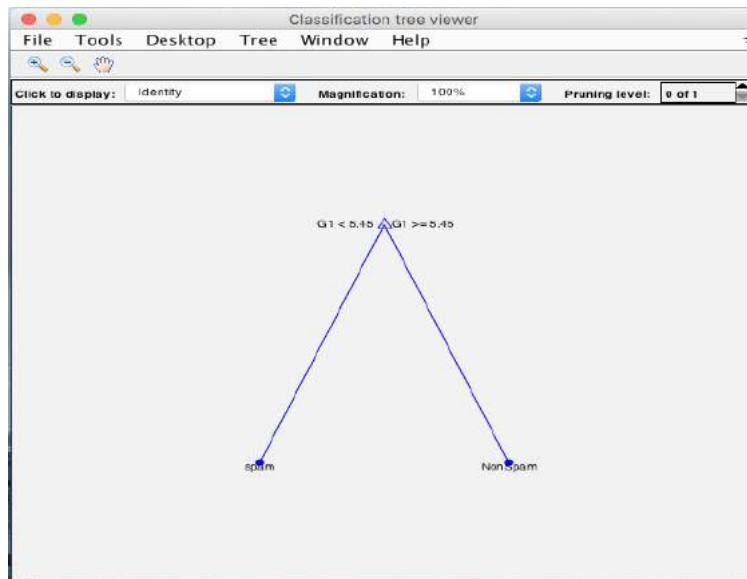

Figure 5: Decision Tree Implementation



**Figure 6:** Pruning

This the best level of decision tree. It gives the best result of classification.

### COMPARISON AND CLASSIFICATION

So, we have used different algorithms in which we hav calculated resubstitution error rate to find the least error.

**Table 1:** Comparison and Classification of different Algorithms

<i>Method</i>	<i>No. of Mismatch</i>	<i>Error Rate</i>
Linear Distribution	28	0.1867
Quadratic Distribution	25	0.1667
Naïve Based Gaussian Distribution	30	0.200
Naïve Based Kernel Distribution	28	0.1867
Decision Tree Classification	20	0.133

Above calculations and comparison proves that decision tree provides the best results for the classification. No. of mismatch are least in the decision tree. Hence, the error rate is controlled. Spam can be categorized now in efficient amount of time.

### CONCLUSION

The presented work shows the email filtering and clustering of the filtered email saved in the database. The email sifting is based upon the separating procedures like white rundown and boycotts sifting strategies or for the most part Bayes hypothesis and decision

tree. The sifting of the email is based upon the expansions of the records, similar to doc documents, jpg records, and compress records. After the separating, messages which are sifted and spared in the database are bunched. All the calculation and visualization have been done using MATLAB tool. Grouping of the messages is based upon the K-implies calculation and SVM calculation. Email sifting and bunching is the fundamental work in my exploration. Past calculation was utilized to channel the email just for the spam. The work is improved by the past one and is actualized to give better results by naïve based and decision tree ID3 algorithm. The best method to do the spam filtering is through the Decision tree algorithm.

### **FUTURE SCOPE**

The scope and future of email filtering system thus looks extremely popular and is bright for services which ranges from email archiving to retrieval and spam filtration. Reality has been etched in bold that email is definitely the best communication way for almost all organizations and this digital mode of passing messages has been typically considered as a mission critical system in today's corporate environment. Thus the flexibility and security of email is needed in comparison.

#### **1. Supervised Learning Algorithm based Categorization**

The concept of email categorization using decision tree is best. We can make it more efficient by applying it to the larger data. Decision tree can be customized to make it more flexible.

#### **2. E-Mail Classification based on Encrypted Message**

This application allows user to fetch messages from the server and after decrypting the encrypted messages, performs classification on the message only. Execute the classification algorithms on the basis of the information obtained. The best solution will be selected amongst all the decrypted texts as a result.

#### **3. Analysis of Spam Rate based on Location**

It can prove to be a really helpful feature that can be implemented based on location analysis of spam.

### **REFERENCES**

- [1] B. Hoanca, "How good are our weapons in the spam wars?" *IEEE Technology and Society Magazine*, vol. 25, no. 1, pp. 22-30, 2006.
- [2] E.-S. M. El-Alfy, "Learning Methods for Spam Filtering," *International Journal of Computer Research*, vol. 16, no. 4, 2008.
- [3] C. C. Wang, "Sender and receiver addresses as cues for anti-spam filtering," *Journal of Research and Practice in Information Technology*, vol. 36, no. 1, pp. 3-7, 2004.
- [4] British Computer Society, <http://www.bcs.org/>.
- [5] H. Drucker, D. Wu, and V. N. Vapnik, "Support vector machines for spam categorization," *IEEE Transactions on Neural Networks*, vol. 10, no. 5, pp. 1048-1054, 1999.
- [6] G. Sakkis, I. Androutsopoulos, and G. Paliouras, "A memory-based approach to anti-spam filtering," *Information Retrieval*, vol. 6, pp. 49- 73, 2003.

- [7] J. Provost, "Naïve-Bayes vs. rule-learning in classification of email," The University of Texas at Austin, Department of Computer Sciences, Technical Report AI-TR-99-284, 1999.
- [8] Y. Yang, S. Elfayoumy, "Anti-spam filtering using neural networks and Bayesian classifiers," in *Proceedings of the 2007 IEEE International Symposium on Computational Intelligence in Robotics and Automation*, Jacksonville, FL, USA, June 2007.
- [9] M. Sahami, S. Dumais, D. Heckerman, and E. Horvitz, "A Bayesian approach to filtering junk e-mail," in *Proceedings of AAAI'98 Workshop on Learning for Text Categorization*, Madison, WI, July 1998.
- [10] E.-S. M. El-Alfy and F. S. Al-Qunaieer, "A fuzzy similarity approach for automated spam filtering," in *Proceedings of IEEE International Conference on Computer Systems and Applications (AICCSA'08)*, Qatar, April 2008.
- [11] K.Cios, W.Pedrycz, and R.Swiniarski, "Data Mining Methods for Knowledge Discovery", Boston: Kluwer Academic Publishers, 1998.
- [12] Wang Xizhao, Sun Juan, Yang Hongwei, Zhao Minghua, "A Comparison between Fuzzy and Crisp Decision Trees", *Computer Engineering and Applications*, 2003 , 39(21) :72-75.
- [13] Wang Jinfeng, Wang Xizhao, "Comparison of Two Decision Tree Induction Algorithm", *Computer Engineering and Applications*,2003, 29: 92-95.
- [14] Wang Tao, Li Zhou-Jun, Hu Xiao-Hua, Yan Yue-J in, Chen Huo- Wang, "An Incremental Fuzzy Decision Tree Classification Method for Data Streams Mining Based on Threaded Binary Search Trees", *Chinese Journal of Computers*, Aug. 2007, Vol. 30 No. 8.
- [15] Zeidler J, Schlosser M, "Continuous-valued attributes in fuzzy decision trees", *Proceedings of the 6th International Conference on Information Processing and Management of Uncertainty in Knowledge-Based Systems*, 1996 : 395-400.
- [16] Guetova M , Holldobter, Storr HP, "Incremental fuzzy decision trees", *Proceedings of the 25th Annual German Conference on Artificial Intelligence*, 2002 .



# Encryption And Embedding in all Multimedia Files

SUHA KHAN, TANVI BAKSHI<sup>1</sup> AND AVDHESH GUPTA<sup>1</sup>

## Abstract

*Data transferred over a network suffers from various attacks which can lead to the disclosure of important and secret information. Sometimes, there can be spam messages also which may have some threat posing information. So, to prevent our data from all such attacks and to provide a better security, in this paper, we proposed a technique of encrypting and then embedding the data in multimedia files such as audio, video, text and images. The major advantage of this software is that it includes all types of carrier files to hide the data of any format depending on our need using both Cryptography and Steganography giving double security to the information.*

## INTRODUCTION

Due to the vast growth of technology, it is important and very much needed to make data out of the reach of unauthorised persons. Various advanced cryptanalytic techniques have been evolved which takes no time to decipher the secure information. So, it is important to develop a software that can provide and ensure all the three basic securities - Confidentiality, Integrity and

Availability. The main reason to develop such a system is to provide a double security to all the different types of files irrespective of their formats.

This paper proposes that all multimedia files can carry hidden information among them without any disturbance and loss of their data. Two things must be ensured while encrypting and hiding the data into carrier files, I.e.

- The embedded data which is first encrypted must be hidden in such a way that it remains undetectable by the human eyes. There should be no sign of disturbance in the carrier file due to hiding of the data.
- The file must be properly recovered at the receiver's end, de-embedding all the hidden information into it. [3]

Encryption along with embedding requires a lot of technique and can only be decrypted with a large no of brute force attacks. Normal cryptanalytic methods fail to decipher the hidden data. The application of De-embedding, Decryption should be a reverse process at the other end and should be translated only when the receiver of the data applies the proper reversal key.

---

<sup>1</sup> IMS Engineering College, Ghaziabad suhaxhan08@gmail.com, suhaxhan08@gmail.com  
avvipersonal@gmail.com

So, Tiny Encryption Algorithm along with Embedding done through Modified F5 algorithm are used for both the encryption and embedding giving a new advanced version of cryptography.[1]

## **LITERATURE REVIEW**

### **Cryptography**

Cryptography is the study of techniques of encrypting and decrypting the information so that it changes into a non-readable format by a third party.

Modern cryptography involves both the concepts of mathematics and computer science to encode the data. But due to the advancement of technology all the techniques are somewhat attacked and decoded by the attackers. So, it must be used with some other techniques to ensure a tight security.[6]

### **Steganography**

Steganography is the science of hiding or embedding secret data into another data or file such that it is not visible. It is one step ahead of cryptography and makes the data totally hidden into a file from unauthorised users. The carrier file should not be distorted by any embedding in it and the data must not be lost. [3]

### **Embedding in Audio files**

Audio files contain different frequencies which are first converted into digital format so that the data can be hidden in the bits.

Human ears are the most sensitive and hence can locate even a slight change in any audio. So, various methods have been proposed for hiding data in audio signals such as-

- Phase coding
- Parity coding
- Spread spectrum

All of the above methods make use of frequencies which may provide some distortion in the carrier files. [5]

### **Embedding in image and video files**

Videos, if seen properly constitute of frames which changes every second to make it a video. Each frame has an image and thus embedding of images and videos are almost same.

Embedding inside image and video files requires make use of redundant bits they have. Embedding with these redundant tends to make no impact on the original or carrier file and hence no data is lost during the process. [4]

DCT method is used to embed the data into the videos in a way that it rounds off the values of the redundant bits.

### Embedding in text files

All the data hiding or embedding in a text are done in the holes or the redundancies such that the size of the file should not increase and also the hidden data must not be visible to the human eye and not produce any distortion in the text file risking its integrity.

This is the most difficult type steganography since there is less number of spaces or holes in text files leading to the embedding of only short files in the carrier or cover file.

### PROPOSED WORK

In this paper, we have proposed double security scheme for the data. Both encryption and embedding is provided with a better and modified version such that it remains secure against various security threats. Till now, data is embedded only in images or video files frequently. But through this proposed technique all the types of data can be hidden along with encryption in any type of multimedia file.

### Encryption Algorithm

We have used a variant and better version of TEA (Tiny encryption Algorithm) which is a feistel type encryption algorithm. The encrypted data using this advanced version of TEA is then embedded in the carrier files. [1][2]

Here, the algorithm is a block cipher and takes less memory and is faster than other encryption algorithms like DES, AES etc.

It uses 128 bit key which is split into four 32 bit subkeys–  $k[0]$ ,  $k[1]$ ,  $k[2]$  and  $k[4]$  and has 64 rounds which makes it hard to attack.

The data is divided into two subparts Left and Right. Both of them are applied with different functions and then swapped in the next round.

Four hexadecimal constants are used, i.e. Alpha, Beta, gamma and Delta. Their values are user defined and are used to XOR with the right subpart of the data.

Here, the data is continuously divided into left and right parts until it has 32 bits left in each, where a Function is applied to it involving the constants and the subkeys.

### Description of a round

$$L_i = R_{i-1}$$

$$R_i = L_{i-1} + F(R_{i-1} + k[0], k[1])$$

Where  $R_{i-1} + K$  stands for-

$$(R_{i-1} \ll 4 + k[0]) \text{ XOR } (R_{i-1} \gg 4 + k[1]) \text{ XOR } (R_{i-1} + \alpha)$$

The decryption of the algorithm requires analyzing and guessing the subkeys and the hexadecimal constants which are difficult and need a lot of computations. The possible combinations are very large approx  $2^{32}$ .

### Embedding

Embedding of all the files are done through ratio wise method, i.e. the data file to be hidden is embedded into the cover file proportionately according to their size.

For example, if the cover file is of 500 MB and the data file is of 100 MB, then data file is to be hidden in the ratio of 5:1. As after every 5 bits of cover file comes 1 bit of the data to be hidden. This is a symmetric method and hence takes time to embed the data depending upon the size of the cover file.

The image and the video files are embedded using a modified version of F5 algorithm.

Here, DCT (Discrete Cosine Transformation) is used to embed the data. The DCT is calculated from the matrix generated of each image in a frame of a video and simply the values are round off slightly enough not to disturb the video.

The DCT coefficients are embedded with the encrypted file that is to be hidden in the cover file.

The one and only limitation of this technique is that the size of the file to be hidden should be small enough than the size of the cover file as it embeds the data ratio wise. So, whenever the information to be hidden is large than we should a comparatively larger file as a cover file.

## RESULT AND CONCLUSIONS

This modified and advanced technique of encrypting and embedding the files of all different formats is better and overcomes the limitations of DES, AES and basic TEA algorithms.

It provides double security to the data over the network. The attacker, first have to de-embed the file and then decrypt it to have the information which is next to impossible to do. It can be used in future works as a good and better alternative to send the secret and important information securely.

## REFERENCES

- [1] Virmani, D., Beniwal, N., Mandal, G., & Talwar, S. (2013). Enhanced Tiny Encryption Algorithm with Embedding (ETEA). *arXiv preprint arXiv:1306.6920*.
- [2] Kumar, A., et al (2010). Steganography-A data hiding technique. *International Journal of Computer Applications*, 9(7), 19-23.
- [3] Anderson, R. J., & Petitcolas, F. A. (1998). On the limits of steganography. *IEEE Journal on selected areas in communications*, 16(4), 474-481.
- [4] Katzenbeisser, S., & Petitcolas, F. (2000). *Information hiding techniques for steganography and digital watermarking*. Artech house.
- [5] Adriansyah, Y. (2010). Simple Audio Cryptography. *Institute Teknologi Bandung Indonesia*.
- [6] Cole, E. (2003). Hiding in plain sight. *Steganography and the Art of Covert Communication*, Wiley..

# Encryption and Embedding in all Multimedia Files

SUHA KHAN<sup>1</sup>, TANVI BAKSHI<sup>1</sup>, AND AVDHESH GUPTA<sup>1</sup>

## Abstract

*Data transferred over a network suffers from various attacks which can lead to the disclosure of important and secret information. Sometimes, there can be spam messages also which may have some threat posing information. So, to prevent our data from all such attacks and to provide a better security, in this paper, we proposed a technique of encrypting and then embedding the data in multimedia files such as audio, video, text and images. The major advantage of this software is that it includes all types of carrier files to hide the data of any format depending on our need using both Cryptography and Steganography giving double security to the information.*

## INTRODUCTION

Due to the vast growth of technology, it is important and very much needed to make data out of the reach of unauthorised persons. Various advanced cryptanalytic techniques have been evolved which takes no time to decipher the secure information. So, it is important to develop a software that can provide and ensure all the three basic securities - Confidentiality, Integrity and Availability. The main reason to develop such a system is to provide a double security to all the different types of files irrespective of their formats.

This paper proposes that all multimedia files can carry hidden information among them without any disturbance and loss of their data. Two things must be ensured while encrypting and hiding the data into carrier files, I.e.

- The embedded data which is first encrypted must be hidden in such a way that it remains undetectable by the human eyes. There should be no sign of disturbance in the carrier file due to hiding of the data.
- The file must be properly recovered at the receiver's end, de-embedding all the hidden information into it. [3]

Encryption along with embedding requires a lot of technique and can only be decrypted with a large no of brute force attacks. Normal cryptanalytic methods fail to decipher the hidden data. The application of De-embedding, Decryption should be a reverse process at the other end and should be translated only when the receiver of the data applies the proper reversal key.

---

<sup>1</sup> IMS Engineering College, Ghaziabad

E-mail: suhaxhan08@gmail.com, suhaxhan08@gmail.com avvipersonal@gmail.com

So, Tiny Encryption Algorithm along with Embedding done through Modified F5 algorithm are used for both the encryption and embedding giving a new advanced version of cryptography.[1]

## **LITERATURE REVIEW**

### **Cryptography**

Cryptography is the study of techniques of encrypting and decrypting the information so that it changes into a non-readable format by a third party.

Modern cryptography involves both the concepts of mathematics and computer science to encode the data. But due to the advancement of technology all the techniques are somewhat attacked and decoded by the attackers. So, it must be used with some other techniques to ensure a tight security.[6]

### **Steganography**

Steganography is the science of hiding or embedding secret data into another data or file such that it is not visible. It is one step ahead of cryptography and makes the data totally hidden into a file from unauthorised users. The carrier file should not be distorted by any embedding in it and the data must not be lost. [3]

### **Embedding in Audio Files**

Audio files contain different frequencies which are first converted into digital format so that the data can be hidden in the bits.

Human ears are the most sensitive and hence can locate even a slight change in any audio. So, various methods have been proposed for hiding data in audio signals such as-

- Phase coding
- Parity coding
- Spread spectrum

All of the above methods make use of frequencies which may provide some distortion in the carrier files. [5]

### **Embedding in Image and Video Files**

Videos, if seen properly constitute of frames which changes every second to make it a video. Each frame has an image and thus embedding of images and videos are almost same.

Embedding inside image and video files requires make use of redundant bits they have. Embedding with these redundant tends to make no impact on the original or carrier file and hence no data is lost during the process. [4]

DCT method is used to embed the data into the videos in a way that it rounds off the values of the redundant bits.

### Embedding in Text Files

All the data hiding or embedding in a text are done in the holes or the redundancies such that the size of the file should not increase and also the hidden data must not be visible to the human eye and not produce any distortion in the text file risking its integrity.

This is the most difficult type steganography since there is less number of spaces or holes in text files leading to the embedding of only short files in the carrier or cover file.

### PROPOSED WORK

In this paper, we have proposed double security scheme for the data. Both encryption and embedding is provided with a better and modified version such that it remains secure against various security threats. Till now, data is embedded only in images or video files frequently. But through this proposed technique all the types of data can be hidden along with encryption in any type of multimedia file.

### Encryption Algorithm

We have used a variant and better version of TEA (Tiny encryption Algorithm) which is a feistel type encryption algorithm. The encrypted data using this advanced version of TEA is then embedded in the carrier files. [1][2]

Here, the algorithm is a block cipher and takes less memory and is faster than other encryption algorithms like DES, AES etc.

It uses 128 bit key which is split into four 32 bit subkeys–  $k[0]$ ,  $k[1]$ ,  $k[2]$  and  $k[4]$  and has 64 rounds which makes it hard to attack.

The data is divided into two subparts Left and Right. Both of them are applied with different functions and then swapped in the next round.

Four hexadecimal constants are used, i.e. Alpha, Beta, gamma and Delta. Their values are user defined and are used to XOR with the right subpart of the data.

Here, the data is continuously divided into left and right parts until it has 32 bits left in each, where a Function is applied to it involving the constants and the subkeys.

### Description of a Round

$$L_i = R_{i-1}$$

$$R_i = L_{i-1} + F(R_{i-1} + k[0], k[1])$$

Where  $R_{i-1} + K$  stands for-

$$(R_{i-1} \ll 4 + k[0]) \text{ XOR } (R_{i-1} \gg 4 + k[1]) \text{ XOR } (R_{i-1} + \text{alpha})$$

The decryption of the algorithm requires analyzing and guessing the subkeys and the hexadecimal constants which are difficult and need a lot of computations. The possible combinations are very large approx  $2^{32}$ .

### Embedding

Embedding of all the files are done through ratio wise method, i.e. the data file to be hidden is embedded into the cover file proportionately according to their size.

For example, if the cover file is of 500 MB and the data file is of 100 MB, then data file is to be hidden in the ratio of 5:1. As after every 5 bits of cover file comes 1 bit of the data to be hidden. This is a symmetric method and hence takes time to embed the data depending upon the size of the cover file.

The image and the video files are embedded using a modified version of F5 algorithm.

Here, DCT (Discrete Cosine Transformation) is used to embed the data. The DCT is calculated from the matrix generated of each image in a frame of a video and simply the values are round off slightly enough not to disturb the video.

The DCT coefficients are embedded with the encrypted file that is to be hidden in the cover file.

The one and only limitation of this technique is that the size of the file to be hidden should be small enough than the size of the cover file as it embeds the data ratio wise. So, whenever the information to be hidden is large than we should a comparatively larger file as a cover file.

## RESULT AND CONCLUSIONS

This modified and advanced technique of encrypting and embedding the files of all different formats is better and overcomes the limitations of DES, AES and basic TEA algorithms.

It provides double security to the data over the network. The attacker, first have to de-embed the file and then decrypt it to have the information which is next to impossible to do. It can be used in future works as a good and better alternative to send the secret and important information securely.

## REFERENCES

- [1] Virmani, D., Beniwal, N., Mandal, G., & Talwar, S. (2013). Enhanced Tiny Encryption Algorithm with Embedding (ETEA). *arXiv preprint arXiv:1306.6920*.
- [2] Kumar, A., et al (2010). Steganography-A data hiding technique. *International Journal of Computer Applications*, 9(7), 19-23.
- [3] Anderson, R. J., & Petitcolas, F. A. (1998). On the limits of steganography. *IEEE Journal on selected areas in communications*, 16(4), 474-481.
- [4] Katzenbeisser, S., & Petitcolas, F. (2000). *Information hiding techniques for steganography and digital watermarking*. Artech house.
- [5] Adriansyah, Y. (2010). Simple Audio Cryptography. *Institute Teknologi Bandung Indonesia*.
- [6] Cole, E. (2003). Hiding in plain sight. *Steganography and the Art of Covert Communication*, Wiley..



# Overview of Attacks and Security Threats in Wireless Sensor Networks (WNS)

PRAGYA TRIPATHI<sup>1</sup>, SANTOSH KUMAR<sup>2</sup> AND VIKAS SINGH<sup>3</sup>

## Abstract

*WSN is a very popular technology now-a-days. It is a technology by which spatial distributed sensor is tracking the environmental or physical conditions for the efficiency of energy. This paper is actually used for testing the mechanism of security which is basically constructed for application and network layers. WSN application could be seen in several places like in defense, health care, environment, industrial monitoring etc. For example; to track any terrorist in LOC there are sensors distributed beneath the ground so that the soldier get to know that something is wrong. WSN plays a major role in this. Different type of topologies and cluster based gives good hold up, advantages, functionalities and output in numerous of applications through which no of routing protocols which are cluster based evolved in WSN.*

**Keywords:** *WSN, Security, Applications, WSN Attacks, Routing Protocols.*

## INTRODUCTION

WSN is basically a provision of sensors. Every network of sensor contains plenty of segments: a radio, a battery, micro-controller, analog circuit and sensor interface. The entire network worked simultaneously by using different dimensions of sensors and worked on the phenomenon of multi routing algorithm which is also termed as wireless adhoc networking. The best advantage of WSN is that it is used in wide aspect and in any harsh or critical condition. They have no disturbance of cables and has mobility. It store limited source of energy. There are many applications of WSN which are used for examine, analyzing and scanning. The designing of routing protocol is the chief constraint in WSN along with bounded power of sensor nodes which is used for making the communication protocol with efficient energy. The routing is based upon Cluster Based Routing scheme which is the meet prominent used scheme in static and mobile WSN. Sensors are divided into a different type of clusters where every cluster include Cluster Head (CH) which helps to gather information in cluster form every member nodes.

---

<sup>1</sup> P.G Scholar, Department of CSE, NGF CET, Faridabad (UP)

<sup>2</sup> Assistant Professor, Department of CSE, NGF CET, Faridabad (UP)

<sup>3</sup> Assistant Professor, Department of CSE, IILM CET, Gr. Noida (UP)

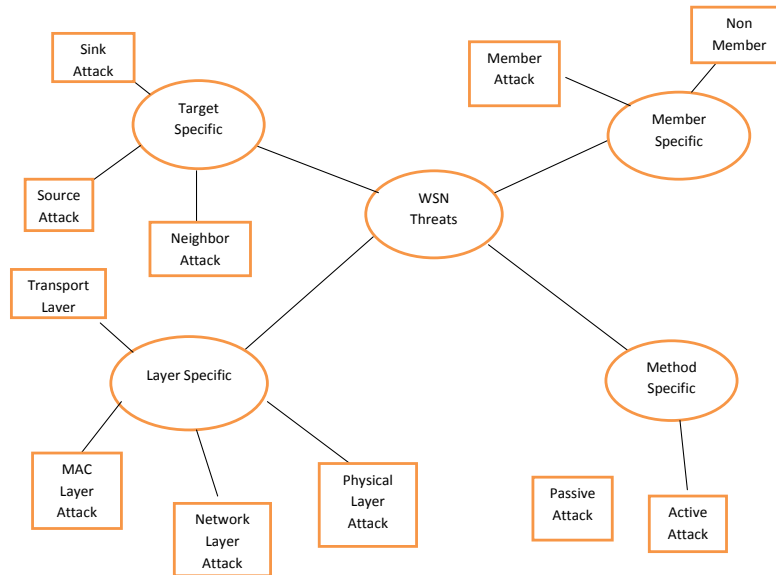

Figure 1: Structure of WSN Threats

**NEED OF SECURITY**

To make WSN communication method secure different types of security requirements are needed which can be broadly explained as :

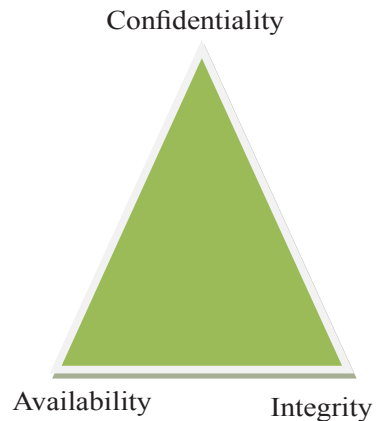

Figure 2: Basic Need of security

**Confidentiality**

To maintain the privacy of any information and within an individual this security parameter is used. It is one of most vital role used in security service.

### Integrity

Intruder or cannot steal or change the communicated messages. Generally, CRC (Cyclic Redundancy Checksum) method is used for scanning the errors. The main task of it is to secure the data at the time of transmission.

### Availability

There are different types of attacks who enable the attacks by which network performance is reduced or abrupt the whole network. The denial of service is one of the major injurious attack in the network availability.

### Authentication

This is the most important aspect of security. It is used just to keep the communicating nodes specification private. Each node present in the network is verified again and again at the time of transmission.

### Privacy

This security requirement is to ensure that the data reaches to only its correct destination. By sending data with security to correct destination it maintains the privacy of user as well as sender.

### Survivability

This is one of the important need of security in which a system capability is seen to fulfil its mission, in the presence of attacks in timely manner.

### Time Synchronization

Synchronization of time is very sensitive and important part of security in sensor networks. It is very difficult and inaccurate to identify object by the sensor if there is a variation in time

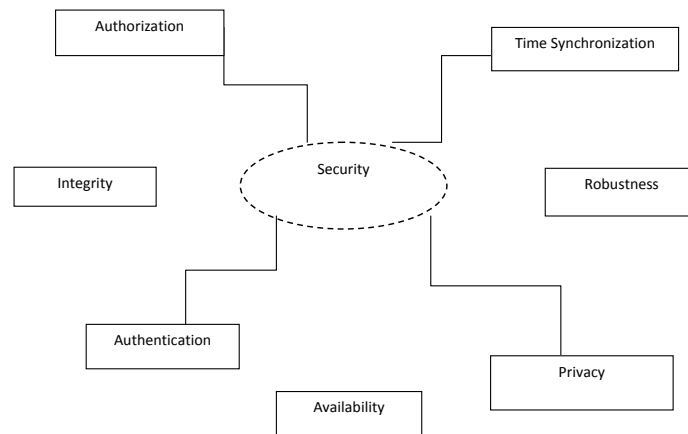

**Figure 3:** Security requirements in WSN

## **RESTRICTION IN WSN**

A WSN is made up of expanding sensor nodes which are resource limited devices. The power is restricted of the nodes at time of processing data, less volume for keeping data and restricted bandwidth of communication. It is hard to deploy the security mechanism in WSN's because of its restricted energy and small size of the sensor nodes.

### **Memory Restrictions**

When storage space is less memory utilization will be less. Similarly, goes with sensors also. Similarly, goes with sensors also. Sensor contains less space for storing any data so less amount of memory is utilized. Sensor node is basically a memory that consists of flash memory and RAM. All the application code is stored in flash memory and application program is stored in RAM. After loading the application code and OS it is very much hard to execute complex algorithms due to less space.

### **Energy Restrictions**

Energy is the main restriction of WSN. It is studied that whenever transmission happens in WSN at time WSN cost same power which is used for executing 800 to 1000 instructions. The energy utilization is partitioned into 3 segments: - a.) Energy used for transmission purpose, b.) Energy used for microprocessor computation. c.) energy used in transducer of sensor.

### **Higher Latency**

It is very much difficult to attain synchronization and major reason behind this is in packet transmission it including multi-hop routing, network congestion and dealing with intermediate nodes in WSN. As discussed above synchronization is hard to achieve, but for safety purpose synchronization is the chief concern as some mechanism depends on cryptographic key distribution and critical event reports.

### **Unreliable Communication**

This is one of the major threats to the security of sensor. As it is a connectionless device so connectionless protocol is used on which packet based routing of sensor network relies. Because, of channel errors packets damaged. In many circumstances, if the channel is reliable, then it is not necessary that the communication is also reliable. When packets retransmit they collide with each other this situation takes place.

### **The Neglecting Action of Networks**

In some methods, nodes are actually located in remote areas that are neglected in WSN. This is one of the reason due to which surrounding sensor confronts a bodily attack which is high.

## **CHALLENGES IN WSN**

- (a) For holding the proper utilization of resources, resource restriction is used viz. energy aware routing etc.

- (b) To eliminate the crash of non-awaited node failures fault tolerance. Study of reliability and its mechanism are done to hold non-authentic wireless transmission.
- (c) For holding non global identification for sensor nodes data-centric paradigm is used for focusing on produced data by group of sensors.
- (d) Dynamic situations and supreme surrounding are used for holding adaptive network operation.
- (e) It is important to implement fusion of data and localized sorting techniques for removing redundancy of data.

## **ATTACKS ON WSN**

Security is the most important concern in WSN. There are many ways as nodes are situated in hazardous environment. In these types of situations, the physical safety of nodes is in danger which gives an outcome that WSN have covered by vulnerability.

### **Denial of Service Attack**

In this type of attack an intended user is refusing some service. It happened by hostile activity. The unnecessary packets are send by the intruder which causes an easiest way that one can utilizes all the resources which are achievable to the sufferer node. As a result, it hurdles (obstructs) individuals in a network from obtaining services via which this attack is calculated to destroy and reduce the set up of a network. This attack is found in all the layers of OSI and each layer has different roles like in physical layer this attack is used for jamming and tampering purpose. In data link layer it is used for weakness and crashing purpose. In network layer, they could be neglected, directionless and homing and in transport layer, it could be desynchronization, poisonous and flooding.

### **Sybil Attack**

This attack is very dangerous because in this node pretend to be more than one node by using the identity of other legitimate nodes. One of the examples is storage distribution. There are 3 categories which are a replica of this type of data evolved. It consist of three nodes two nodes can easily minimize the redundancy. This attack easy come under the influence of fault tolerant plants storage allocation and network topology which are protocols and algorithm.

### **Black Hole Attack**

To attract all the traffic in the network some spiteful node acts as a black hole or sinkhole. The main aim of this type of attack is to convince all the traffic from a special network by compromising a node and making a hole at the base station. It is very hard to counter as the compromising holes takes interest in routing algorithms in which attack can act. It is also termed as sink hole attack.

### **Hello Flood Attack**

This step is taken as a measure to get the sensor nodes in confidence. To acquire the access to the WSN the unauthorized node uses HELLO packet. Congestion is the major issue that we face in this. It is one of the easiest attacks from the entire above, where attacker sends

the message like HELLO to both sender and receiver with great capacity and power. In this, blocking methods are used to secure Hello Flood Attacks.

### Wormhole Attack

In this attack, reply over a network in which low latency connection is there between two parts that contain messages which are known as wormhole. Both sinkhole and wormhole attack have similar functions. Direct node accepts this kind of link and directs the messages between two neighboring nodes which are adjacent to each other or by a pair of nodes which are in different segments in network so that they can communicate with each other.

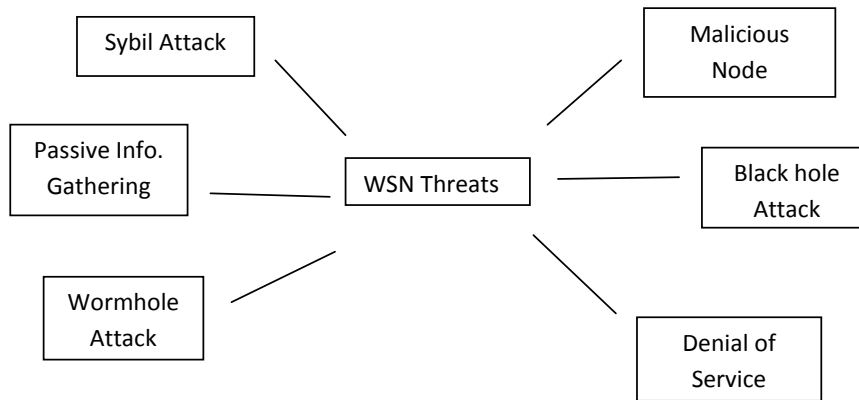

**Figure 4:** Threats in WSN

## CONCLUSION

In this paper, many constraints, challenges, restrictions and security mechanism have discussed. There are many methods and protocols have been evolved in this network. The security is the major concern in WSN as due to these attacks found in WSN for avoiding this several mechanism which have been evolved which are data confidentiality, privacy, time synchronization and much more discussed in this paper. During the evolvement of WSN's request for security becomes clear. It has many constraints which are discussed as the limited amount of energy, processing of data and storing volume. Although, previously there were not many mechanisms to provide protection. But, now-a-days several solutions are there for avoiding any dangerous activity. This type of mechanism makes WSN different from other networks.

## REFERENCES

- [1] Neha rang, Anuj gupta, "Wireless Sensor Networks : A Overview", IJMCS, Vol.1,iss.2, 2013.
- [2] C. Karlof , D. Wagner , " Secure routing in wireless sensor networks : attacks And countermeasures", In proc. Of the 1st IEEE Int. workshop on sensor network Protocols and applications (SNPA'03) , pp. 113-127, May 2003.
- [3] Aashima Singla , Ritika Sachdeva, "Review on security issues and attacks in Wireless sensor networks", IJARCSSE, vol. 3, iss. 4, 2013.

- [4] Kriti Jain, Upasana Bahuguna, "Survey on Wireless Sensor Network", *IJSTM*, Vol. 3, Issue 2, pp. 83-90, Sept 2012.
- [5] Dr. Manoj Kumar Jain, "Wireless Sensor Networks: Security Issues and Challenges", *IJCIT*, vol. 2, issue 1, pp. 62- 67, 2011
- [6] Tin Win Maw, Myo Hein Jaw, "A secure for mitigation of DoS attack in cluster Based wireless sensor networks", *IJCCER* , vol. 1, Issue 3, 2013
- [7] Prajeet Sharma, Nireesh Sharma, Rajdeep Singh, "A Secure Intrusion detection System against DDOS attack in Wireless Mobile Ad-hoc Network", *IJCA*, Vol. 41– No.21, March 2012.
- [8] Snehlata Yadav, Kamlesh Gupta, Sanjay Silakari, "Security issues in wireless Sensor network", *Journal of information system and communications*, vol.1, issue 2, 2010, pp-01-06
- [9] J. C. Choi and C. W. Lee, "Energy modeling for the cluster-based sensor networks," In *Proceedings of the Sixth IEEE International Conference on Computer and Information Technology*, pp. 218, September 20–22 2006.
- [10] S. Selvakennedy and S. Sinnappan, "An energy-efficient clustering algorithm for multi-hop data gathering in wireless sensor networks," *Journal of Computers*, pp. 1, April 2006.
- [11] Wendi B. Heinzelman, Anantha P. Chandrakasan, Hari Balakrishnan, "An Application-Specific Protocol Architecture for Wireless
- [12] *Microsensor Networks*", *IEEE Transactions On Wireless Communications*, Vol. 1, No. 4, October 2002.
- [13] Meena Malik, Dr. Yadhvir Singh and Anshu Arora, "Analysis of LEACH Protocol in Wireless Sensor Networks", *IJARCSSE*, volume 3, Issue 2, February 2013.
- [14] Rajesh Patel, Sunil Pariyani, and Vijay Ukani, "Energy and Throughput Analysis of Hierarchical Routing Protocol (LEACH) for Wireless Sensor Network", *IJCA*, volume 20-No.4, April 2011.
- [15] Ravneet Kaur, Deepika Sharma and Navdeep Kaur, "Comparative Analysis Of LEACH and its Descendant Protocols in Wireless Sensor Network", *IJP2PNTT*, volume 31, Issue 1, 2013.
- [16] Parth M Dave and Purvang D Dalal, "Simulation and Performance Evaluation of Routing Protocols in Wireless Sensor Network", *IJARCCCE*, volume 2, Issue 3, March 2013.
- [17] V.B. Thakar, C.B Desai and S.K. Hadia, "Performance Evaluation and Improvement of LEACH-A Wireless Sensor Network Protocol using a Novel Algorithm for Clustering", *Journal of Information, Knowledge and Research in Electronics and Communication Engineering*.
- [18] Mortaza Fahimi Khaton Abad and Mohammad Ali Jabraeil Jamali, "Modify LEACH Algorithm for Wireless Sensor Network", *IJCSI*, volume 8, Issue 5, No 1, September 2011.

# Weat-We Are There

MUKTA TIWARI<sup>1</sup> AND SHIVANSH SINGH<sup>2</sup>

## ABSTRACT

*Many unfortunate incidents have been taking place regarding safety of people. Problems come from any direction such as women walking on the road after the work, going to super market or many other reasons for which they go alone. People at home are not sure of their return safely. In order to overcome such problems faced by people mobile based application is not only necessary to use but also plays a pivotal role with android software. Android is a Java based operating system which mainly runs on the Linux 2.6 Kernel. Huge number of mobile applications are developed using java. Smart phones are equipped with various features like GPS navigation, touch screen, broadband access and many more. These facilities of smart phones will help us to connect with the modern world. Various applications are developed in android and this is one of the applications for security purpose. This paper describes about a SOS application being developed and its successful implementation.*

*A web application is also designed for the same app that registers the users and allows them to view or edit their details. Using the web application the user will enter its details. Two preferred locations where he/she stays preferably. Entering the address will be through Google maps. Once registered the user will have the facility to view and edit his or her details.*

*The application helps those who surprisingly fall into a situation where instant communication is needed. If any emergency situation occurs or whenever anyone fall in trouble then this application will help them by tracking their location using GPS system. GPS system will track the location of the registered user and with the help of location they can help the needy persons who had fallen into emergency situation, but the user first have to register him/her to provide the location and the GPS connection should be on for sending message.*

*In this paper, we describe a revolutionary mobile app which is specifically designed with the perspective of providing safety to its users by serving as an efficacious personal safety device. Loaded with several GPS location tracking and emergency contacts, this app is capable of sending the emergency messages. A fully functional security app, It will be equipped with some of the most astounding features including reports, events, emergency contacts, GPS integration, custom push notification, co-attendeas of the events and capability to function efficiently in multiple event types.*

**KEYWORDS:** GPS, SMS, SOS, Android, apps, android, mobile, safety.

## INTRODUCTION

Ban Ki-Moon, the secretary general of United Nations stated that “There is one universal truth, applicable to all countries, cultures and communities: violence against women is

---

<sup>1</sup> Computer Science Department, IMS Engineering College, Ghaziabad, India

<sup>2</sup> Computer Science Department, IMS Engineering College, Ghaziabad, India



never acceptable, never excusable, and never tolerable” [1]. Not just for women but we all should thrive to make our surroundings better, where the fellow citizens can come to help others in their time of need. An app is a small, specialized software program, easily downloadable and installed onto mobile devices such as Smartphone’s or tablet computers. The use of apps has been popularized by the App’s App Store and also by Google’s Play Store[2]

There are three reasons why the app will be of help to anyone who is in need. It is easily accessible, crowd sourcing and affordable scalability. Text messaging services are now a day’s being used by everyone in daily life for easy communication or mainly for emergency situations. The Emergency Alert System is a media communication system that is designed to transmit emergency messages [3].

This paper describes about an app that aims at serve its user it their time of need. WEAT application is developed in android platform. It is based on the assumption that the registered users will not use any unfair means and genuinely want to help fellow users. The uniqueness of this application is that the registered users can send a message to all the nearby users of the same app as well as its emergency contacts when he/she needs help. All the registered users get the message getting the coordinates of people in need. Whether the person wants to send a message to nearby users or only to the emergency contacts is solely the wish of the users for the security purposes. Using this app a user can be assured of the fact that at any given time help will be provided.

Some other advanced features of the app include deciding the level of emergency for which the user needs help. There are three levels of emergencies- Casual, Mild and Urgent. The feature that distinguishes this app from all others is that does not only aim at providing security for women. But this app can come in handy in a lot of situations from the simple event of car breaking down to a medical emergency. To motivate people to come to each others help we will have reward points.

## **LITERATURE SURVEY**

### **Existing Android SOS Application**

There are lot of Android applications are available today. There are SOS based applications too which are developed using android platform. Some of the SOS applications are listed below. This application provides instructions for dealing with a variety of emergencies, including choking, strokes, allergic reactions and many more.

#### **(a) SOS Emergency support prepared by Red Cross**

This application provides step-by-step instructions on dealing with a variety of emergencies, including choking, strokes, allergic reactions and many more. It is a free application; it provides no. of videos to coach a person through emergency protocols. If a person is not from the US, the application determines what country the person is in and dials the appropriate number [4].

### **(b) Olal Ashe Emergency Alert Button (SOS)**

Olal Ashe Emergency SOS is an emergency SOS application. It allows entering in-case-of-emergency contact from phonebook. Send SMS to registered contacts that the user is in trouble & Click the widget button to trigger the application [1].

### **(c) Vith U app.**

The popular Indian crime television series “Gumrah” initiated towards developing an emergency app for women security. The working of this app is such that we have to press the power button. In this app when the twice consecutively and it will start sending messages with a link to the location of the user.

### **Existing models:**

This paper describes four models which describes overall implementation of the project.

1. Registration of the user.
2. Register the numbers.
3. Check if GPS service is available or not.
4. Sending the text message to the respective numbers.

### **Registration of the user**

First the users have to register her/him with some details. WEAT app will work only for the registered users. If the user is already registered then for using this app the user does not need to login again and again.

### **Register the numbers**

After registration of the user the users have to register the contacts of his/her family members to whom the message will be sent in case of emergency. After pressing the SOS button the emergency message will be sent to the pre-registered numbers

### **Check if GPS service is available or not**

1. Some of the packages used to accomplish retrieving the location using GPS services are android. For tracking the location of the user the GPS service must be available on your phone.
2. GPS will track the exact current location of the person.
3. It will receive the information in the form of latitude and longitude.
4. This process will be held in background that as soon as the user press the SOS button ,it will first check whether your phone has GPS system on or not and it will send the message only if the GPS system is enabled on your phone.

### **Sending the message to the other users as well as emergency contacts**

1. As soon as the alert button is pressed the emergency message will be sent to the respective numbers.

2. The SOS button is pressed and the location in the form of latitude and longitude will be sent to the registered contacts.

## **PROBLEM IDENTIFICATION**

### **PROPOSED WORK**

#### **Web Application**

A web application is also designed for the same app that registers the users and allows them to view or edit their details. Using the web application the user will enter its details. Two preferred locations where he/she stays preferably. Entering the address will be through Google maps. Once registered the user will have the facility to view and edit his or her details.

#### **Android Application**

The WEAT is also an important mobile based application, which is used to provide facility to the customer who suffers from any emergency. The proposed model is to be designed with a objective such that it has to be user friendly and triggering of the application should take less time. In emergency situation the location of the user must known precisely to all those persons to whom the message will be sent. For full functioning this application demands the GPS service to be available in the mobile phone. .If the phone don't have GPS service and attempt to trigger this application then it will show an error message, but continue to send a message to the registered phone numbers. This feature of this application is helpful for those users who don't have GPS enabled in their handset. Another feature of this app is deciding the level of emergency for which the user needs help. There are three levels of emergencies- Casual, Mild and Urgent. The feature that distinguishes this app from all others is that does not only aim at providing security for women. But this app can come in handy in a lot of situations from the simple event of car breaking down to a medical emergency. To motivate people to come to each others help we will have reward points.

## **METHODOLOGY**

### **Technology Used**

1. **ASP.NET:** ASP.NET is a web development platform, which provides a programming model, a comprehensive software infrastructure and various services required to build up robust web applications for PC, as well as mobile devices.
2. **C#:** C# is an elegant and type-safe object-oriented language that enables developers to build a variety of secure and robust applications that run on the .NET Framework. You can use C# to create Windows client applications, XML Web services, distributed components, client-server applications, database applications, and much, much more
3. **JAVA:** Java is a simple and yet powerful object oriented programming language and it is in many respects similar to C++. Java originated at Sun Microsystems, Inc.

in 1991. It was conceived by James Gosling, Patrick Naughton, Chris Warth, Ed Frank, and Mike Sheridan at Sun Microsystems, Inc. It was developed to provide a platform-independent programming language.

### Software Used

1. **Android Studio:** It's an Android focused IDE, designed specially for the Android development. It was launched on 16th May 2013, during Google I/O 2013 annual event. Android studio contains all the Android SDK tools to design, test, debug and profile your app. By looking at the development tools and environment, we can its similar to eclipse with the ADT plug-in but as I have mentioned above its android focused IDE, there are many cool features available in Android Studio which can foster and increase your development productivity.
2. **Microsoft Visual Studio:** Microsoft Visual Studio is an integrated development environment (IDE) from Microsoft. It is used to develop computer programs for Microsoft Windows, as well as web sites, web applications and web services. Visual Studio uses Microsoft software development platforms such as Windows API, Windows Forms, Windows Presentation Foundation, Windows Store and Microsoft Silverlight. It can produce both native code and managed code.

### Platform Compatibility

1. **Android:** The Android OS is an open source operating system primarily used in mobile devices. Written primarily in Java and based on the Linux operating system, it was initially developed by Android Inc. and was eventually purchased by Google in 2005. The Android operating system is symbolized by a green colored Android Robot logo. The development of the Android OS was a result of the consortium of the initial members of the Open Handset Alliance (OHA) such as Google, HTC, Dell, Intel, Motorola, Qualcomm, Texas Instruments, Samsung, LG, T-Mobile, Nvidia, and Wind River Systems back in November of 2007. The OHA is a business alliance of hardware, software and telecom companies dedicated to advance the cause of open sourcing for mobile phones

### Working

The website should ask user to register every time the web is accessed. During Registration the user is asked to enter including 5 emergency contacts and two preferred locations. After Registration the user is sent an activation email which can be used to activate their account. All the emergency contacts are sent a sms informing them about the same. The user can also save their username and password for easy access in future.

Once the user is registered he can download the app for future use from playstore. The app requires an active gps and is based on the assumption that the registered user will not cater to wrong methods using the data of the app. Whenever the user finds himself in a situation where he needs help in form of medical help or any other kind of assistance as well as he needs his dear ones know about his emergency he can simply do so using

the app. Opening the app he can chose the level of emergency he is in. three kinds of emergencies being casual, mild and urgent. The user will be asked if he wants to send message to only his emergency contacts or to the nearby users of the same app or both.

Depending on the choice of the user the message will be sent to respective emergency contacts with the coordinates and a request message along with the contact number. Then the users can get help. The main aim of this app is to get help to its users in time of need.

### **Advantages**

1. It is user efficient.
2. WEAT sends a message requesting for help to all nearby users of the same app to ensure that help is provided.
3. The app does not send a preformatted text in every situation. Instead the user's message is forwarded to everyone bringing into the notice of what the person in need wants to communicate.
4. There are two kinds of buttons for sending a help message. So that all possible situations can be covered.

### **CONCLUSION**

WEAT is the "Android based safety Triggering Application" which is very useful application mainly for helping each other. When we feel that we are in emergency situation such as travelling alone at night time, we can use this application so that on one click our location will sent to our family members or the other users. This application mainly based on GPS service which will track the location of the user appropriately. So this application is having both safety and security which is essential in today's world.

### **REFERENCES**

- [1]. Report of the Fourth World Conference on Women. New York, United Nations, 1995 (A/CONF.177/20/Rev.1) (<http://www.un.org/womenwatch/confer/beijing/reports/>, accessed 1 April 2013).
- [2] Nicole Westmarland, Mariann Hardey, et al. "Protecting Women's Safety? The use of smartphone „apps“ in relation to domestic and sexual violence", Durham University, Durham centre for research into violence and abuse (2013)
- [3] L.Hariprasath1,R.Dhivya2,S.Adithya3, "Emergency Alert System Using Android" IJREAT International Journal of Research in Engineering & Advance Technology,Volume 1,Issue 1,March2013.
- [4] Dhruvajyoti Gogoi, "Android Based Emergency Alert Button"International Journal of Innovative Technology and Exploring Engineering(IJITEE) ISSN:2278-3075,Volume-2,Issue-4,March 2013

# Weat-We Are There

MUKTA TIWARI<sup>1</sup> AND SHIVANSH SINGH<sup>2</sup>

## Abstract

*Many unfortunate incidents have been taking place regarding safety of people. Problems come from any direction such as women walking on the road after the work, going to super market or many other reasons for which they go alone. People at home are not sure of their return safely. In order to overcome such problems faced by people mobile based application is not only necessary to use but also plays a pivotal role with android software. Android is a Java based operating system which mainly runs on the Linux 2.6 Kernel. Huge number of mobile applications are developed using java. Smart phones are equipped with various features like GPS navigation, touch screen, broadband access and many more. These facilities of smart phones will help us to connect with the modern world. Various applications are developed in android and this is one of the applications for security purpose. This paper describes about a SOS application being developed and its successful implementation.*

*A web application is also designed for the same app that registers the users and allows them to view or edit their details. Using the web application the user will enter its details. Two preferred locations where he/she stays preferably. Entering the address will be through Google maps. Once registered the user will have the facility to view and edit his or her details.*

*The application helps those who surprisingly fall into a situation where instant communication is needed. If any emergency situation occurs or whenever anyone fall in trouble then this application will help them by tracking their location using GPS system. GPS system will track the location of the registered user and with the help of location they can help the needy persons who had fallen into emergency situation, but the user first have to register him/her to provide the location and the GPS connection should be on for sending message.*

*In this paper, we describe a revolutionary mobile app which is specifically designed with the perspective of providing safety to its users by serving as an efficacious personal safety device. Loaded with several GPS location tracking and emergency contacts, this app is capable of sending the emergency messages. A fully functional security app, It will be equipped with some of the most astounding features including reports, events, emergency contacts, GPS integration, custom push notification, co-attendees of the events and capability to function efficiently in multiple event types.*

**Keywords:** GPS, SMS, SOS, Android, Apps, Android, Mobile, Safety

## INTRODUCTION

Ban Ki-Moon, the secretary general of United Nations stated that “There is one universal truth, applicable to all countries, cultures and communities: violence against women is

---

<sup>1</sup> Computer Science Department, IMS Engineering College, Ghaziabad (UP)

<sup>2</sup> Computer Science Department, IMS Engineering College, Ghaziabad (UP)

never acceptable, never excusable, and never tolerable” [1]. Not just for women but we all should thrive to make our surroundings better, where the fellow citizens can come to help others in their time of need. An app is a small, specialized software program, easily downloadable and installed onto mobile devices such as Smartphone’s or tablet computers. The use of apps has been popularized by the App’s App Store and also by Google’s Play Store[2]

There are three reasons why the app will be of help to anyone who is in need. It is easily accessible, crowd sourcing and affordable scalability. Text messaging services are now a day’s being used by everyone in daily life for easy communication or mainly for emergency situations. The Emergency Alert System is a media communication system that is designed to transmit emergency messages [3].

This paper describes about an app that aims at serve its user it their time of need. WEAT application is developed in android platform. It is based on the assumption that the registered users will not use any unfair means and genuinely want to help fellow users. The uniqueness of this application is that the registered users can send a message to all the nearby users of the same app as well as its emergency contacts when he/she needs help. All the registered users get the message getting the coordinates of people in need. Whether the person wants to send a message to nearby users or only to the emergency contacts is solely the wish of the users for the security purposes. Using this app a user can be assured of the fact that at any given time help will be provided.

Some other advanced features of the app include deciding the level of emergency for which the user needs help. There are three levels of emergencies- Casual, Mild and Urgent. The feature that distinguishes this app from all others is that does not only aim at providing security for women. But this app can come in handy in a lot of situations from the simple event of car breaking down to a medical emergency. To motivate people to come to each others help we will have reward points.

## **LITERATURE SURVEY**

### **Existing Android SOS Application**

There are lot of Android applications are available today. There are SOS based applications too which are developed using android platform. Some of the SOS applications are listed below. This application provides instructions for dealing with a variety of emergencies, including choking, strokes, allergic reactions and many more.

#### **(a) SOS Emergency Support Prepared by Red Cross**

This application provides step-by-step instructions on dealing with a variety of emergencies, including choking, strokes, allergic reactions and many more. It is a free application; it provides no. of videos to coach a person through emergency protocols. If a person is not from the US, the application determines what country the person is in and dials the appropriate number [4].

### **(b) Olal Ashe Emergency Alert Button (SOS)**

Olal Ashe Emergency SOS is an emergency SOS application. It allows entering in-case-of-emergency contact from phonebook. Send SMS to registered contacts that the user is in trouble & Click the widget button to trigger the application [1].

### **(c) Vith U app**

The popular Indian crime television series “Gumrah” initiated towards developing an emergency app for women security. The working of this app is such that we have to press the power button. In this app when the twice consecutively and it will start sending messages with a link to the location of the user.

### **Existing Models**

This paper describes four models which describes overall implementation of the project.

1. Registration of the user.
2. Register the numbers.
3. Check if GPS service is available or not.
4. Sending the text message to the respective numbers.

### **Registration of the User**

First the users have to register her/him with some details. WEAT app will work only for the registered users. If the user is already registered then for using this app the user does not need to login again and again.

### **Register the Numbers**

After registration of the user the users have to register the contacts of his/her family members to whom the message will be sent in case of emergency. After pressing the SOS button the emergency message will be sent to the pre-registered numbers

### **Check if GPS Service is Available or Not**

1. Some of the packages used to accomplish retrieving the location using GPS services are android. For tracking the location of the user the GPS service must be available on your phone.
2. GPS will track the exact current location of the person.
3. It will receive the information in the form of latitude and longitude.
4. This process will be held in background that as soon as the user press the SOS button ,it will first check whether your phone has GPS system on or not and it will send the message only if the GPS system is enabled on your phone.

### **Sending the message to the other users as well as emergency contacts**

1. As soon as the alert button is pressed the emergency message will be sent to the respective numbers.



2. The SOS button is pressed and the location in the form of latitude and longitude will be sent to the registered contacts.

## **PROBLEM IDENTIFICATION**

### **PROPOSED WORK**

#### **Web Application**

A web application is also designed for the same app that registers the users and allows them to view or edit their details. Using the web application the user will enter its details. Two preferred locations where he/she stays preferably. Entering the address will be through Google maps. Once registered the user will have the facility to view and edit his or her details.

#### **Android Application**

The WEAT is also an important mobile based application, which is used to provide facility to the customer who suffers from any emergency. The proposed model is to be designed with a objective such that it has to be user friendly and triggering of the application should take less time. In emergency situation the location of the user must known precisely to all those persons to whom the message will be sent. For full functioning this application demands the GPS service to be available in the mobile phone. .If the phone don't have GPS service and attempt to trigger this application then it will show an error message, but continue to send a message to the registered phone numbers. This feature of this application is helpful for those users who don't have GPS enabled in their handset. Another feature of this app is deciding the level of emergency for which the user needs help. There are three levels of emergencies- Casual, Mild and Urgent. The feature that distinguishes this app from all others is that does not only aim at providing security for women. But this app can come in handy in a lot of situations from the simple event of car breaking down to a medical emergency. To motivate people to come to each others help we will have reward points.

## **METHODOLOGY**

### **Technology Used**

1. **ASP.NET:** ASP.NET is a web development platform, which provides a programming model, a comprehensive software infrastructure and various services required to build up robust web applications for PC, as well as mobile devices.
2. **C#:** C# is an elegant and type-safe object-oriented language that enables developers to build a variety of secure and robust applications that run on the .NET Framework. You can use C# to create Windows client applications, XML Web services, distributed components, client-server applications, database applications, and much, much more
3. **JAVA:** Java is a simple and yet powerful object oriented programming language and it is in many respects similar to C++. Java originated at Sun Microsystems, Inc.

in 1991. It was conceived by James Gosling, Patrick Naughton, Chris Warth, Ed Frank, and Mike Sheridan at Sun Microsystems, Inc. It was developed to provide a platform-independent programming language.

### Software Used

1. **Android Studio:** It's an Android focused IDE, designed specially for the Android development. It was launched on 16th May 2013, during Google I/O 2013 annual event. Android studio contains all the Android SDK tools to design, test, debug and profile your app. By looking at the development tools and environment, we can its similar to eclipse with the ADT plug-in but as I have mentioned above its android focused IDE, there are many cool features available in Android Studio which can foster and increase your development productivity.
2. **Microsoft Visual Studio:** Microsoft Visual Studio is an integrated development environment (IDE) from Microsoft. It is used to develop computer programs for Microsoft Windows, as well as web sites, web applications and web services. Visual Studio uses Microsoft software development platforms such as Windows API, Windows Forms, Windows Presentation Foundation, Windows Store and Microsoft Silverlight. It can produce both native code and managed code.

### Platform Compatibility

1. **Android:** The Android OS is an open source operating system primarily used in mobile devices. Written primarily in Java and based on the Linux operating system, it was initially developed by Android Inc. and was eventually purchased by Google in 2005. The Android operating system is symbolized by a green colored Android Robot logo. The development of the Android OS was a result of the consortium of the initial members of the Open Handset Alliance (OHA) such as Google, HTC, Dell, Intel, Motorola, Qualcomm, Texas Instruments, Samsung, LG, T-Mobile, Nvidia, and Wind River Systems back in November of 2007. The OHA is a business alliance of hardware, software and telecom companies dedicated to advance the cause of open sourcing for mobile phones

### Working

The website should ask user to register every time the web is accessed. During Registration the user is asked to enter including 5 emergency contacts and two preferred locations. After Registration the user is sent an activation email which can be used to activate their account. All the emergency contacts are sent a sms informing them about the same. The user can also save their username and password for easy access in future.

Once the user is registered he can download the app for future use from playstore. The app requires an active gps and is based on the assumption that the registered user will not cater to wrong methods using the data of the app. Whenever the user finds himself in a situation where he needs help in form of medical help or any other kind of assistance as well as he needs his dear ones know about his emergency he can simply do so using

the app. Opening the app he can chose the level of emergency he is in. three kinds of emergencies being casual, mild and urgent. The user will be asked if he wants to send message to only his emergency contacts or to the nearby users of the same app or both.

Depending on the choice of the user the message will be sent to respective emergency contacts with the coordinates and a request message along with the contact number. Then the users can get help. The main aim of this app is to get help to its users in time of need.

### **Advantages**

1. It is user efficient.
2. WEAT sends a message requesting for help to all nearby users of the same app to ensure that help is provided.
3. The app does not send a preformatted text in every situation. Instead the user's message is forwarded to everyone bringing into the notice of what the person in need wants to communicate.
4. There are two kinds of buttons for sending a help message. So that all possible situations can be covered.

### **CONCLUSION**

WEAT is the "Android based safety Triggering Application" which is very useful application mainly for helping each other. When we feel that we are in emergency situation such as travelling alone at night time, we can use this application so that on one click our location will sent to our family members or the other users. This application mainly based on GPS service which will track the location of the user appropriately. So this application is having both safety and security which is essential in today's world.

### **REFERENCES**

- [1]. Report of the Fourth World Conference on Women. New York, United Nations, 1995 (A/CONF.177/20/Rev.1) (<http://www.un.org/womenwatch/confer/beijing/reports/>, accessed 1 April 2013).
- [2] Nicole Westmarland, Mariann Hardey, et al. "Protecting Women's Safety? The use of smartphone, apps "in relation to domestic and sexual violence", Durham University, Durham centre for research into violence and abuse (2013)
- [3] L.Hariprasath1,R.Dhivya, S. Adithya, "Emergency Alert System Using Android" IJREAT International Journal of Research in Engineering & Advance Technology,Volume 1,Issue 1,March2013.
- [4] Dhruvajyoti Gogoi, "Android Based Emergency Alert Button"International Journal of Innovative Technology and Exploring Engineering(IJITEE) ISSN:2278-3075,Volume-2, Issue-4, March 2013

# India Towards Cashless Economy

RAJAT GUPTA<sup>1</sup>

## Abstract

*In an attempt to eradicate black money, counterfeit currency and paving the way for a cashless society, the Central Government Of India announced demonetization of Rs.500 and Rs 1000 in November 8<sup>th</sup> 2016. This paper seeks to investigate problems and prospects of cashless economy and the challenges in making India a cashless economy. Adoption of cashless system is more beneficial to both economy and public but implementing this in an economy is a very tedious process since the digital literacy and usage of digital means and digital transaction is very low in public. This paper aims to study demonetization in India. It aims to identify the impact of demonetization on the political structure of the country and its impact on the Indian economy it also studies the challenges associated with the implementation of demonetization in Indian economy and **Government of India** has introduced some digital payment methods to ease the digitalization process like UPI USSD, AEPS, etc, and announced concessions for digital users. The process is still continuing. India is going cashless...and here's why. Over the last decade mobile technology has flourished throughout the developing world much faster than any other technology. The latest offspring of mobile technology is mobile money. Mobile money is allowing millions, the 'unbanked population' (especially in the developing countries) to safely transfer money and pay bills without the hassles of handling cash. This paper is about future prospects and challenges before India to become a cashless economy.*

**Keywords:** Demonetization, Cashless Economy, Digitalization, Plastic Money, Mobile Money

## INTRODUCTION

In India many transactions are done in cash as it is quite easier for making payments in any way ranging from high value to low value transactions. Because of this many people are able to evade tax and can make black money which is not good for the growth of any economic condition of the nation. Therefore looking at this condition the Government of India made an announcement on 8<sup>th</sup> November 2016 stating the high value currency note will not have legal tenure from midnight of 8<sup>th</sup> November 2016. This is one of the most important steps taken by the Government of India to eradicate black money, counterfeit currency and paving the way for a cashless society.

Cashless economy is the situation in which the cash flow in the economy is non-existent and all transactions are made through online or electronic channels such as debit cards, credit cards and payment systems such as National Electronic Fund Transfer (NEFT) Real Time Gross Settlement (RTGS) in India. Today debit cards, credit cards and

---

<sup>1</sup> MBA 1st Year, Mangalmai Institute of Management & Technology Greater Noida (UP)

online payment services are increasing rapidly in the economy but paper note are also very essential for daily life. Cash may be defined as any legal medium of exchange that is immediately negotiable and free of legal restriction.

We are the fourth largest user of cash in the world. The rate of cash to GDP is the highest i.e. 12.42% in India. Cash in circulation to private consumption ratio in India is 20% and cards transaction accounts for 4 % of personal consumption expenditure. As most of people are illiterate, poor engaged in small transactions and having less banking habits. For them cash is the most convenient and easy form of medium of exchange, free from restriction. A cash transaction is immediate and doesn't involve any intermediary. Cash provides individuals and families with liquidity.

### **BLACK MONEY IN INDIA**

Black money is the biggest problem for Indian economy. It leads to less tax for the government, uncontrollable inflation, mass poverty, impact on growth by moving investment on gold, stone and jewellery, corruption, inflated real estate, transfer of fund abroad, encourages anti social activities, increase in inequalities of income, wasteful consumption, decrease in working efficiency of people and so on. A number of administrative and legislative policies have been formulated by the Government of India for estimating black economy searches; seizure, surveys, and scrutiny of income tax returns are being done. Introducing the scheme of special bearer bonds, demonetizing high denomination currency notes, to curb black money. Amendments have also been made to the finance act 2004 to intensify efforts. India has tried to combat tax evasion by permanent account number for all major financial deals. Prevention of money laundering act enacted in the year 2005 is a core measure to curb the problem of money laundering. Further, the legislature introduced the black money and imposition of tax act in the year 2015 to tackle this problem.

### **EFFECTS OF DEMONETISATION**

After the demonetisation announced in India there was dramatic change in the market condition and in the behaviour of the people of India. Due to which there was decrease in cash transaction and people are moving toward digitalization by which they are making online transaction. There was increase in use of debit cards, credits cards, and other payment facilities available in the market which is more familiar with the people. For the Government of India has also taken a serious step towards eradicating the black money and making India a cashless economy. According to data by RBI, there were already 135 million mobile wallet users in India in comparison to 22 million credit cards by November 2015. This data shows that the people of India are also willing to move ahead. According to the survey done by the International Monetary Fund India is fastest growing economy in the world and one of the most emerging nation towards cashless economy.

Also with lower cash transaction in the near future inflation rate will come down in near future and also with higher tax to GDP ratio, the government may also get enough source to reduce the income tax, which can lead to higher disposal income with people and can improve consumption demand in near future. Before demonetisation the circulation of fake Indian currency note was more and funding to terrorist group was more due to which

terrorist activities was done by various terrorist group. After the effective implementation of demonetisation all these activities are controlled and the circulation of fake Indian currency note was under control. All these also result in low terrorist attack in India.

As a result of demonetisation, many financial transaction that were not reported as an economic activity would now be added to the GDP, therefore it will only add to the GDP, not reduce the GDP. With the upcoming election in five state in 2017 demonetisation has also curbed the undeclared fund of the political parties. By this move many new account have been opened, bank branches have been growing, ATMs, debit cards, credit cards and card swiping machine have increased, online transaction has grown up. Consumer who are otherwise preferring cash transaction have now adopted online payment facilities and other means of online transaction. This adoption of online payment and digitalization many e-commerce website and e-wallet as well as other mobile wallet company have got the opportunity to grow up and this help to develop the economic condition of nation and may lead to the economic growth of the nation.

### **Pros of Demonetisation**

- *Attack on black money holder:* people who are holding huge amount of hard cash with them are now in complete loss and they have to show their identity to deposit that cash and also have to provide detail information about that holding.
- *Death knell to fake currency racket:* with the implementation of demonetization in the economy most of organization involving in supply of fake currency have to shut down their operation. As most of the fake currency are of high denomination due to which there is unbalanced economic condition.
- *End of terror funding:* Huge sums of money especially in hard cash in the denominations of Rs. 500 and Rs. 1000 was used to fund Islamic terrorists, Naxalites and other non-state actors now these organization will suffer from shortage of fund. Most of these terrorist organization use fund in buying arms and ammunition now it will be difficult to them in buying such products.
- *End of Huge Donations:* Huge amounts of donation that is taken in the private education and healthcare sectors would be stopped. Huge amounts of donation that is taken in the private education and healthcare sectors would be stopped. Huge amounts of donation that is taken in the private education and healthcare sectors would be stopped.
- *Towards cashless economy:* while it is practically impossible to have 100% cashless economy, the proportion of hard cash in the economy will decrease and our economy will get more digitized. The will result in greater transparency.
- *End of hawla transaction:* most of the hawala transactions are done in 500 & 1000 denomination. With this ban Indian Government has delivered fatal blow to unethical hawala trader as they cannot trade anymore using Rs 500 and Rs1000

### **Cons of Demonetisation**

- *Rush at Bank:* due to shortage of cash people with rush to bank to withdraw and deposit cash which may leads to rush at bank and people will forget everything and

will go the places where banned note are officially exchanged leading to tremendous chaos.

- *Shortage of money with common people:* there will be shortage of money with common people which leads to frustration in the public as they will not be able to buy the necessities product for their daily life.
- *Problem for house wives:* due to demonetization there will rise in problem for house wives because they are not able to purchase those good which are used as basic need. As our Indian house wives use to store money secretly so that they could help during the time of financial crisis in their households, now the accumulated money of our Indian house wives is of no use until they exchange it at bank or post offices.
- *Short term inflation:* due to shortage of money in the market, short term cost push inflation will occur. Prices of vegetable and fruits have also rise up burdening to common man.
- *Marriage season:* when the demonetization occurs in the economy that was the time of marriage season and it leads to increase in difficulties to those families who have weddings at their house as they are not able to purchase goods for the marriage purpose.

#### **CHALLENGES IN TRANSITIONING TO A CASHLESS SOCIETY**

- *Financial Inclusion:* For cashless economy every individual must have access to banking facilities and should hold a bank account with debit/credit cards and online banking facilities.
- *Digital and Financial Literacy:* Ensuring financial and digital inclusion alone is not sufficient to transition to a cashless economy. Individuals should made aware of the financial and digital instrument available and how to operate them.
- *Cyber Security:* digitalization is highly vulnerable to cyber crime, cyber frauds. Hence establishing secure and resilient payment interference is a pre-requisite for going cashless economy.
- *Changing Habits and Attitude:* Indian economy primarily depends on cash due to lack of e-payment mode, digital illiteracy of e-payment and cashless transaction method and habit of handling cash as convince. To go cashless individual should adopt e-payment in an increased manner and take it into a fashion. And spread awareness to initiate behavioural change in habits and attitude.
- *Urban–Rural Divide:* Urban areas are enjoying high speed internet connectivity whereas semi urban and rural areas are deprived of net connection. With regards to presence of ATM's POS terminals and bank branches there exists a significant urban-rural divide and bridging the gap is a must to enable a cashless economy.
- *Number of Mobile Users who are Connected to the Internet:* There were 342.65 million Internet connections by the end of March 2016, of which 20.44 million were wired connections. In total, 149.75 million were on broadband (3G + 4G + wireless broadband) and 192.9 million on “Narrowband”. Narrowband Internet subscriber base was 192.90 million (2G and wireless broadband).

- *Availability of User Devices:* According to Idea Cellular CEO Himanshu Kapania, there are currently over a billion mobile phones in India: around 850 million feature/smart phones, and 150 million LTE enabled phones. That number of people with a smart phone using data is probably around 60% to 70%.
- *No Privacy with Cashless:* A switch to cashless means that each and every transaction is tracked and documented. This is great for governance, with taxation, but there is no protection for citizens, as to who owns that data, whom they can share it with, and how it will be utilized. Enabled in Indian languages. Mobik wik has done English and Hindi. PhonePe works in English, Hindi and Tamil.

## WHY TO ADOPT CASHLESS ECONOMY?

### Benefit to Economy as a Whole

- *Financial Inclusion:* Cashless economy will help to enhance the current banking system. There will be increased access to financial services to people. Financial inclusion will automatically reduce poverty. And availability of credit will also increase at lower rate as the banks will be having sufficient amount of fund to provide credit to their consumer.
- *Reduction in Tax Avoidance:* A transaction in cashless economy is highly transparent. All transactions can be monitored and traced back. So there is lesser scope of hiding income and evading taxation. It will also helps to decrease the burden on those who are paying taxes to the government.
- *Corruption:* E money is easily traceable. No one can demand bribe in cashless economy. Moreover, Red tapism and bureaucracy can be eliminated from the economy.
- *Reduction in Illegal Activities:* Digitalization leads to more transparency in the financial system, which helps in reducing unauthorized cash in the hands of public. It automatically leads to lesser funding for illegal trade and activities inducing terrorism.
- *Reduction of Cost of Printing Notes:* In cashless economy the use of currency notes is very less, as the transactions are mostly undertaken through digital means.
- *Increased Economic Growth:* Electronic transaction helps in curbing tax evasion and increasing money circulation. It boosts the nation's economy. Increased tax base would result in greater revenue for public welfare activities.

### Benefits to Individual

- *Convenience:* Individuals can make transactions without carrying bulky notes. Digital payments can be made with a tap on the mobile phone
- *Safety:* Cashless transactions are highly safe, as it is protected through PIN. Also the individuals are free from the fear of being robbed while carrying cash.
- *Hygiene of notes is not an issue:* Knowingly or unknowingly give and take of germs in the form of currency notes can be avoided.
- *Speed and satisfaction:* No delays, No queues, No interaction with bank officers are required. Transaction can be made from anywhere at any time by just tap on the phone.



### Benefits to Business Concerns

- *Increase the customer base:* Electronic payments and e commerce helps the business concerns to grow their customer base and resource, by transacting in large geographical area.
- *No cash, No problem:* All transactions are undertaken directly through bank accounts, it eliminate the problem of dealing cash. No need to go everyday to deposit cash in bank accounts.
- *Easier accounting:* In cashless economy all transactions are automatically recorded through electronic terminals.

### CONCLUSION

Demonetisation is great move towards a cashless economy but if the cash deposited in banks return in circulation as cash then the Indian economy will dramatically returns to its past. But if black money didn't return to the system then the resurgence in growth may prove to be a challenge in an already sluggish investment scenario. Cash crunch will have a dampening impact on inflation. This will reduce our consumption based economic growth and even deepen instability in currency and assets markets. A better solution would have been simplified and reduces taxes, eliminate loopholes and widen tax base. There is hope and a greater scope for fast transition towards cashless economy. Cashless idea can work when each and every individual come under one roof. Here in India some people are well educated whereas some are thumb users. For the concept of cashless economy to be true in India the centre, the state and the local government should work together to ensure that first every person is financially included in main stream. Second, there has to be option of doing transaction through digital means. Third there is need to ensure safety and security of cashless transaction. The idea of cashless economy is great itself but all these problem and potential threats have to be taken into accounts. If transactions are carried out without physical cash being exchanged, this is beneficial in regulating and curbing the flow of money in the black market as well as illegal and underground economies. In India today, it is the opposite - with the majority of transactions done with cash. This has to stop, India should be technological up-to-date in Banking transactions.

### REFERENCES

- [1] Anand, N. (2016). RBI revs drive towards cashless economy. Business Standard.
- [2] Dasgupta, S. (2016). Demonetisation: Going cashless is not that daunting. The Free Express Journal.
- [3] Dr Meenu Jain, globalization and social transformation: Indian experience research process international journal of the social research foundation vol.2 number1 January-june2014
- [4] Dr Meenu Jain , Structural Change in the Course of Economic Development ; India's
- [5] Experience, Vol.5 issue 5, pp 15-17 Indian Journal of applied Research Journal may 2015
- [6] <http://www.theglobaljournals.com/ijar/issues.php?m=May&y=2015&id=47>
- [7] <https://www.quora.com/What-is-the-history-of-demonetization-of-Indian-Currency>
- [8] <http://blogs.timesofindia.indiatimes.com/cash-flow/demonetization-in-1946-and-1978-stories-from-the-past/>
- [8] <http://www.livemint.com/Opinion/XGbavEnoeP7dZITeh21MRM/Making-India-a-cashless-economy.html>

# Optimization of Shell and Tube Type Heat Exchangers Using Sequential Quadratic Programming Algorithm

ABHISHEK SACHAN<sup>1</sup> AND RAJIVE GUPTA<sup>2</sup>

## Abstract

*Shell and Tube type heat exchangers are having special importance in boilers, oil coolers, condensers and pre-heaters. These are also widely used in process applications as well as the refrigeration and air conditioning industry. The robustness and medium weighted shape of Shell and Tube type heat exchangers make them well suited for high pressure operations. The basic configuration, the thermal analysis and design of such exchangers form an included part of the mechanical, thermal and chemical engineering scholars for their curriculum and research activity.*

*Traditional design approaches using graph sheets are time consuming, these may not considered all the variables and constraints simultaneously. On the other hand some new evolutionary algorithms viz. Genetic Algorithm (GA), Particle swarm optimization (PSO), Imperialist competitive algorithm (ICA) are not simple to understand by every designer and are not easy to be implemented. Therefore, in present work, a new shell and tube heat exchanger optimization design approach is discussed based on sequential quadratic programming (SQP). The SQP algorithm has some good features in reaching to the global minimum in comparison to other evolutionary algorithms. In present study, SQP technique has been applied to minimize the total cost which includes capital investment and total discounted operating cost. The design variables considered in the present work are tube outer diameter, shell diameter and baffle spacing. A matlab code is developed based on SQP for optimal design of shell and tube heat exchangers. The different test cases are solved using code to demonstrate the effectiveness and accuracy of the proposed algorithm. The results using developed code are compared to those obtained from previous literatures. It is found that the SQP algorithm is simple and it can be successfully applied for optimal design of shell and tube heat exchangers with higher accuracy.*

**Keywords:** *Shell and Tube Type Heat Exchangers, Optimal Design, Sequential Quadratic Programming*

---

<sup>1</sup> M. Tech, Department of Mechanical Engineering, Harcourt Butler Technological Institute, Kanpur, (U.P.)

E-mail: abhisheksachan1191@gmail.com

<sup>2</sup> Professor, Department of Mechanical Engineering, Harcourt Butler Technological Institute, Kanpur, (U.P.)

E-mail: rajive\_gupta2003@yahoo.com

## INTRODUCTION

A shell and tube heat exchanger is a class of heat exchanger designs. It is the most common type of heat exchanger in oil refineries and other large chemical processes, and is suited for higher-pressure applications. As its name implies, this type of heat exchanger consists of a shell (a large pressure vessel) with a bundle of tubes inside it. One fluid runs through the tubes, and another fluid flows over the tubes (through the shell) to transfer heat between the two fluids. The set of tubes is called a tube bundle, and may be composed of several types of tubes: plain, longitudinally finned, etc.

Shell and tube type heat exchanger is probably the most used and widespread type of the heat exchanger's classification. It is used most widely in various fields such as oil refineries, thermal power plants, chemical industries and many more. This high degree of acceptance is due to the comparatively large ratio of heat transfer area to volume and weight, easy cleaning methods, easily replaceable parts etc. Shell and tube type heat exchanger consists of a number of tubes through which one fluid flows. Another fluid flows through the shell which encloses the tubes and other supporting items like baffles, tube header sheets, gaskets etc. The heat exchange between the two fluids takes through the wall of the tubes. A schematic diagram of shell and tube type heat exchanger is given below: [1,2]

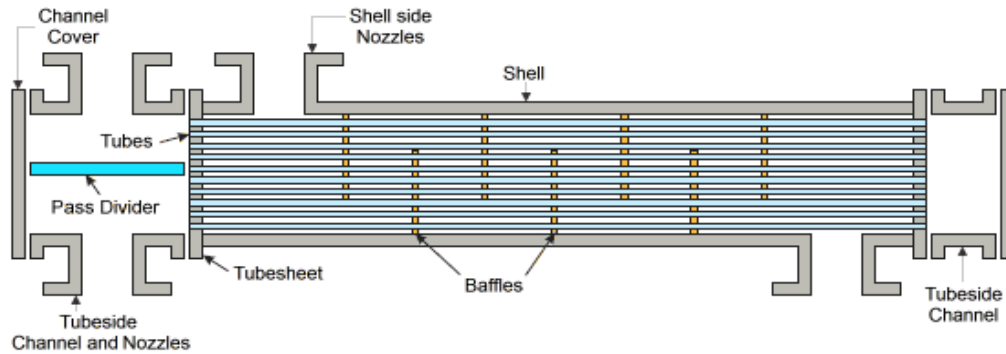

Fig 1.1: A Shell and Tube Type Heat Exchanger [1]

## NOMENCLATURE

$a_1, a_2, a_3$	numerical constant	$N_t$	number of tubes
$a_s$	cross sectional area normal to flow direction ( $m^2$ )	$P$	pumping power (W)
$B$	baffles spacing (m)	$Pr$	Prandtl number
$Cl$	clearance (m)	$P_t$	tube pitch (m)
$C_p$	specific heat (kJ/kg K)	$R_f$	fouling resistance ( $m^2 K/W$ )
$C_i$	capital investment (Rs)	$Q$	heat duty (W)
$C_e$	energy cost (Rs /kW hr)	$Re$	Reynolds number
$C_o$	annual operating cost (Rs/yr)	$S$	heat transfer surface area

(m <sup>2</sup> )		
C <sub>od</sub>	total discounted operating cost (Rs)	T temperature (°C)
C <sub>tot</sub>	total annual cost (Rs)	U overall heat transfer coefficient (W/m <sup>2</sup> K)
d <sub>o</sub>	tube diameter (m)	v fluid velocity (m/s)
D <sub>s</sub>	shell diameter (m)	<b>Greek symbols</b>
f	friction factor	ΔP pressure drop (Pa)
F	correction factor	ΔT logarithmic mean temperature difference
(°C)		
h	heat transfer coefficient (W/m <sup>2</sup> K)	μ dynamic viscosity (Pa s)
H	annual operating time (hr/yr)	ν kinematic viscosity (m <sup>2</sup> /s)
i	annual discount rate (%)	ρ density (kg/m <sup>3</sup> )
k	thermal conductivity (W/m K)	η overall pumping efficiency
K <sub>1</sub>	numerical constant	<b>Subscripts</b>
L	tubes length (m)	i inlet
m	mass flow rate (kg/s)	o outlet
n	number of tubes passages	s belonging to shell
n <sub>y</sub>	equipment life (year)	t belonging to tube
n <sub>1</sub>	numerical constant	

## LITERATURE REVIEW

The basic configuration of shell and tube heat exchangers, the thermal analysis and design of such exchangers form an included part of the mechanical, thermal, chemical engineering scholars for their curriculum and research activity. In recent past year, the improvements in computing cost have increased the interest of engineers and researchers to simulate their problems with computational and numerical methods. A lot of computational tools and methods have been developed in the last decades to analyse fluid dynamics, combustion, and different modes of heat transfer.

Srivastava A.K., Dubey V.V.P., Verma R.R., Verma P.S. have presented an overview of shell and tube type heat exchanger, constructional details, design methods and the reasons for the wide acceptance of shell and tube type heat exchangers [1]. Shah R.K. and Sekulib D.R. have given the classification of shell and tube type heat exchangers based on heat transfer process, constructional features and flow arrangements [2]. Sinnott R.K. has presented various chemical processing equipment theory and design, (e.g. heat exchanger,) [3]. Kern D.Q. has discussed various types of heat transfer processes and design of engineering equipment explained [4].

Caputo A.C., Pelagagge M.P., Saline P., have presented a procedure for optimal design for shell and tube heat exchangers which utilized a genetic algorithm to minimize the total discounted cost of the equipment including the capital investment and pumping related annual energy expenditures [5]. Taal M., Bulatov I., Klemes J., Stehlik P. have given the

most common methods used for cost estimation of heat exchange equipment in the process industry and the sources of energy price projections and considered ten methods for heat exchanger costing procedure [6]. Peters MS, Timmerhaus K.D. have presented methods of plant design and economics. Further these methods are used for calculation of heat exchanger's total annual cost and pressure drop at shell side [7]. Philip G.E., Laurent J.O., Michael L.W., Linda P.R., Sharmad V., have proposed a sequential quadratic programming (SQP) method for the optimal control of large-scale dynamical systems and various steps of sequential quadratic programming method algorithm is also discussed [8]. Philip G.E., Wong E., have proposed the sequential quadratic programming (SQP) method for the solution of constrained nonlinear optimization problems and also compared with other optimization methods [9]. Patel V.K., Rao R.V., have discussed a non-traditional optimization technique; called particle swarm optimization (PSO), for design optimization of shell and tube heat exchangers from economic view point and minimization of total annual cost is considered as an objective function [10]. Hadidi A., Hadidi A., Nazari A., have presented a new design approach for shell and tube heat exchangers using imperialist competitive algorithm (ICA) from economic point of view. ICA technique has been applied to minimize the total cost of the equipment including capital investment and the sum of discounted annual energy expenditures related to pumping of shell and tube heat exchanger. Finally the results are compared to those obtained by other literature approaches [11].

## DESIGN PROCEDURE

The procedure includes the following steps:

- i. Estimation of the exchanger heat transfer area based on the required duty and other design specification assuming a set of design variables values;
- ii. Evaluation of the capital investment, operating cost, and the objective function;
- iii. Utilization of the optimization algorithm to select a new set of values for the design parameters;
- iv. Iteration of the previous steps until a minimum of the objective function is found.

## MATHEMATICAL MODEL

The adopted design procedure is based on the mean logarithm temperature difference approach. According to this method the heat exchange surface area is computed by the following equation: [3,4]

$$S = \frac{Q}{U \Delta T F} \quad \dots 2.1$$

$\Delta T$  the mean logarithm temperature difference resulting from specifications for counter flow:

$$\Delta T = \left\{ \frac{\theta_1 - \theta_2}{\ln\left(\frac{\theta_1}{\theta_2}\right)} \right\} \quad \dots 2.2$$

Where temperature difference  $\theta_1$  and  $\theta_2$  (°C) for counter flow arrangement computed as:

$$\theta_1 = (T_{is} - T_{ot}) \text{ and } \theta_2 = (T_{os} - T_{it})$$

The temperature difference  $F = \left( \frac{\sqrt{R^2+1}}{R-1} \right) \cdot \frac{\ln \left[ \frac{1-P}{1-PR} \right]}{\ln \left[ \frac{2-P(R+1-\sqrt{R^2+1})}{2-P(R+1+\sqrt{R^2+1})} \right]}$  10, 11] 2.3

Where

$$P = (T_{ot} - T_{it}) / (T_{is} - T_{it})$$

$$U = \frac{1}{\left( \frac{1}{h_s} \right) + R_{foul,shell} + R_{foul,tube} + \left( \frac{1}{h_t} \right)}$$
 2.4

$$h_t = \frac{k_t}{d_i} \cdot 0.027 \cdot Re_t^{0.8} \cdot Pr_t^{0.33} \cdot (\mu_t / \mu_w)^{0.14}$$
 2.5

$d_0$  is the tube diameter ( $d_i=0.8d_0$ ),  $\mu_t$  and  $\mu_w$  the fluid viscosity computed at the bulk and wall temperatures ( $\mu_w=0.00057$  Pa-s).

$$h_s = \frac{k_s}{D_e} \cdot 0.36 \cdot Re_s^{0.55} \cdot Pr_s^{0.33} \cdot (\mu_t / \mu_w)^{0.14}$$
 2.6

$$D_e = 4 \cdot \left( 0.43 P_t^2 - \frac{0.5 \pi d_0^2}{4} \right) / (0.5 \pi d_0)$$
 2.7

$$Re_t = \rho_t \cdot v_t \cdot \frac{d_i}{\mu_t} \quad Re_s = \rho_s \cdot v_s \cdot \frac{D_e}{\mu_s}$$
 2.9

$$v_t = \frac{m_t}{\frac{\pi}{4} d_0^2} \cdot \left( \frac{n}{N_t} \right) v_s = \frac{m_s}{(a_s \rho_s)}$$
 2.10

$$a_s = D_s \cdot B \cdot \frac{Cl}{P_t}$$
 2.11

Where  $Cl = P_t - d_0$

$$N_t = K_1 \cdot \left( \frac{D_s}{d_0} \right)^{n_1}$$
 2.12

**Table 2.1:** Values of  $K_1$  and  $n_1$

No. of passes (n)	Triangle tube pitch ( $Pt=1.25d_0$ )		Square tube pitch ( $Pt=1.25d_0$ )	
	K1	n1	K1	n1
1	0.319	2.142	0.215	2.207
2	0.249	2.207	0.156	2.291
4	0.175	2.285	0.158	2.263
6	0.0743	2.499	0.0402	2.617
8	0.0365	2.675	0.0331	2.643

Total cost  $C_{tot}$  (Rs) is taken as the objective function, which includes capital investment ( $C_i$ ) (Rs) and total discounted operating cost ( $C_{od}$ ) (Rs): [5]

$$C_{tot} = C_i + C_{od} \quad \dots 2.13$$

The capital investment  $C_i$  is computed as a function of the exchanger surface adopting Hall's correlation [6]:

$$C_i = a_1 + a_2 S^{a_3} \quad \dots 2.14$$

Where  $a_1 = 8000$ ,  $a_2 = 259.2$  and  $a_3 = 0.91, 0.89$  for exchangers made with stainless steel for both shells and tubes [6].

$$C_o = P \cdot C_e \cdot H \quad 2.15$$

$$C_{od} = \sum_{k=1}^{ny=10} \frac{C_o}{(1+i)^k} \quad 2.16$$

$$P = \frac{1}{\eta} \left( \frac{m_t}{\rho_t} \cdot \Delta P_t + \frac{m_s}{\rho_s} \cdot \Delta P_s \right) \quad 2.17$$

$$\Delta P_t = \Delta P_{\text{tubelength}} + \Delta P_{\text{tube elbow}} \quad 2.18$$

$$\Delta P_t = \frac{\rho_t v_t^2}{2} \cdot \left( L \cdot \frac{f_t}{d_i} + p \right) \cdot n \quad 2.19$$

Different values of constant  $p$  are considered by different authors. Kern [4] assumed  $p = 4$ , while Sinnott [3] assumed  $p = 2.5$ .

Where  $f_t = (1.82 \log_{10} Re_t - 1.64)^{-2}$  is the friction factor,  $L$  is the tube length. The tube length  $L$  (m) is calculated as:

$$L = \frac{S}{\pi d_o N_t} \quad 2.20$$

The shell side pressure drop  $\Delta P_s$  is given as:

$$\Delta P_s = f_s \cdot \left( \rho_s \cdot \frac{v_s^2}{2} \right) \cdot \left( \frac{L}{B} \right) \cdot \left( \frac{D_s}{D_e} \right) \quad 2.21$$

Where  $f_s = 2b_o \cdot Re_s^{-0.15}$  is the friction factor and  $b_o = 0.72$  [7]

## SEQUENTIAL QUADRATIC PROGRAMMING ALGORITHM

Sequential Quadratic Programming (SQP) is one of the most successful methods for the numerical solution of constrained nonlinear optimization problems. It relies on a strong theoretical foundation and provides powerful algorithmic tools for the solution of large-scale technologically relevant problems. The problem which is considered to solve is to minimize some objective or cost function,  $f(x)$ , subject to constraints  $a_i(x) = 0$  for  $i = 1, 2, \dots, p$  and  $c_j(x) > 0$  for  $j = 1, 2, \dots, q$ . The  $f(x)$  can be a linear or nonlinear objective function.  $a_i(x)$  and  $c_j(x)$  are constraints which are functions of  $x$  and can be nonlinear.  $f(x), a_i(x)$  and

$c_j(x)$  are assumed to be continuous and have continuous second partial derivatives, and the feasible region of this problem is assumed to be nonempty. A solution of the such type of problem generally requires an iterative procedure to establish a direction of search at each major iteration. This is usually achieved by the solution of an LP, a QP, or an unconstrained subproblem. The quadratic programming subproblem is created using initial objective function as quadratic and linearizing constraints about a starting point. This method uses constraints steepest descent (CSD) method for search direction. The solution of quadratic programming problem is used as starting point for next iteration; therefore this method is called Sequential Quadratic Programming method. It is important to note that method work equally well when initiated from feasible or infeasible points. It can also treat equality and inequality constraints.

## NUMERICAL DATA AND RESULTS

The effectiveness and validity of the suggested approach in this work is assessed by analyzing some relevant case studies taken from the literature, in order to have reliable reference sizing data for the sake of comparison. The following two different test cases, representative of a wide range of possible applications, are considered. The first case study of this work is a heat exchanger for methanol and brackish water, taken from [3]. The heat load is 4.34 MW. This heat exchanger has two tube side passages with triangle pitch pattern and one shell side passage. The second case study is taken from [4] is a heat exchanger which transfers a heat load of 0.46 MW between distilled water–raw water heat exchanger and has two tube side passages with triangle pitch pattern and one shell side passage. The same configuration of above cases is retained in the present approach. For each case the original design specifications, shown in Table [2,4], were taken as input to the optimization algorithm and the resulting optimal exchangers design parameters given by the SQP method were compared with the original design suggested in literatures [3] and [4].

The following upper and lower bounds for the optimization variables were imposed: Tubes outside diameter  $d_o$  ranging from 0.01 m to 0.051 m; Shell internal diameter  $D_s$  ranging between 0.1 m and 1.5 m; Baffles spacing  $B$  ranging from 0.05 m to 0.5 m.

All values of discounted operating costs were computed with  $n_y=10$  years, annual discount rate=10%, Energy cost  $C_e = 0.12$  Rs/kW hr, And annual amount of work hours =7000 hr/yr similar to other researches. [3, 7, 10, 11]

**4.2 Case study 1:** This case study is taken from Sinnot [3] and the process inputs and physical properties are given in table 4.1:

**Table 4.1:** The process input and physical properties for case study 1

Case-1	m (kg/s)	Ti (°C)	To (°C)	$\rho$ (kg/ m <sup>3</sup> )	Cp (kJ/ kg)	$\mu$ (Pa-s)	k (W/mK)	Rf (m <sup>2</sup> K/W)
Shell side: methanol	27.8	95	40	750	2.84	0.00034	0.19	0.00033
Tube side: sea water	68.9	25	40	995	4.2	0.00080	0.59	0.00020



**Table 4.2:** Parameters of the optimal shell and tube heat exchangers for case study 1 using different optimization methods

Parameters	Literature [3]	GA [5]	PSO [10]	ICA [11]	SQP [present work]
do (m)	0.02	0.016	0.015	0.015	0.015
Ds (m)	0.894	0.83	0.81	0.879	0.786
B (m)	0.356	0.5	0.424	0.5	0.5
L (m)	4.83	3.379	3.115	3.107	3.2115
Pt (m)	0.025	0.02	0.0187	0.01875	0.0188
Cl (m)	0.005	0.004	0.0037	0.00375	0.0037
De (m)	0.014	0.011	0.0107	0.011	0.0107
Nt	918	1567	1658	1752	1550
vt (m/s)	0.75	0.69	0.67	0.699	0.7885
Ret	14925	10936	10503	10429	11769
Prt	5.7	5.7	5.7	5.7	5.7
ht (W/m2K)	3812	3762	3721	3864	4814.5
ft	0.028	0.031	0.0311	0.031	0.030
$\Delta Pt$ (Pa)	6251	4298	4171	5122	7449.8
as (m2)	0.032	0.0831	0.0687	0.0879	0.0786
vs (m/s)	0.58	0.44	0.53	0.42	0.4718
Res	18381	11075	12678	9917	10928
Prs	5.1	5.1	5.1	5.1	5.1
hs (W/m2K)	1573	1740	1950.8	1740	1957
fs	0.33	0.357	0.349	0.362	0.3569
$\Delta Ps$ (Pa)	35789	13267	20551	12367	14318
U (W/m2K)	615	660	713.9	677	740.4033
S (m2)	278.6	262.8	243.2	256.6	234.4616
Ci (Rs)	3863025	3694425	3483975	3627750	3389100
Co (Rs/year)	158325	71025	77902.5	73125	82897.5
Cod (Rs)	972975	436350	508365	449625	509362.5
Ctot (Rs)	4836000	4130775	3992332.5	4077450	3898462.5

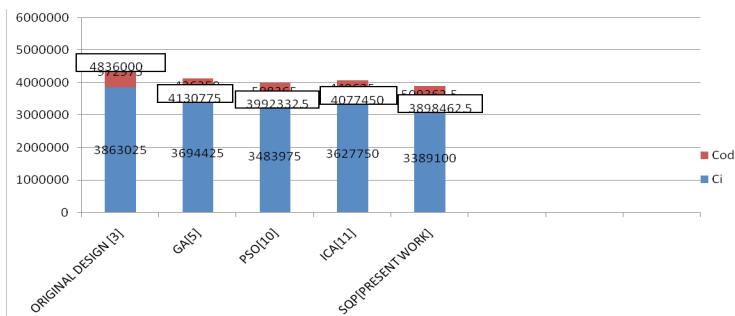
**Fig 4.1:** Cost Comparison for Case Study 1

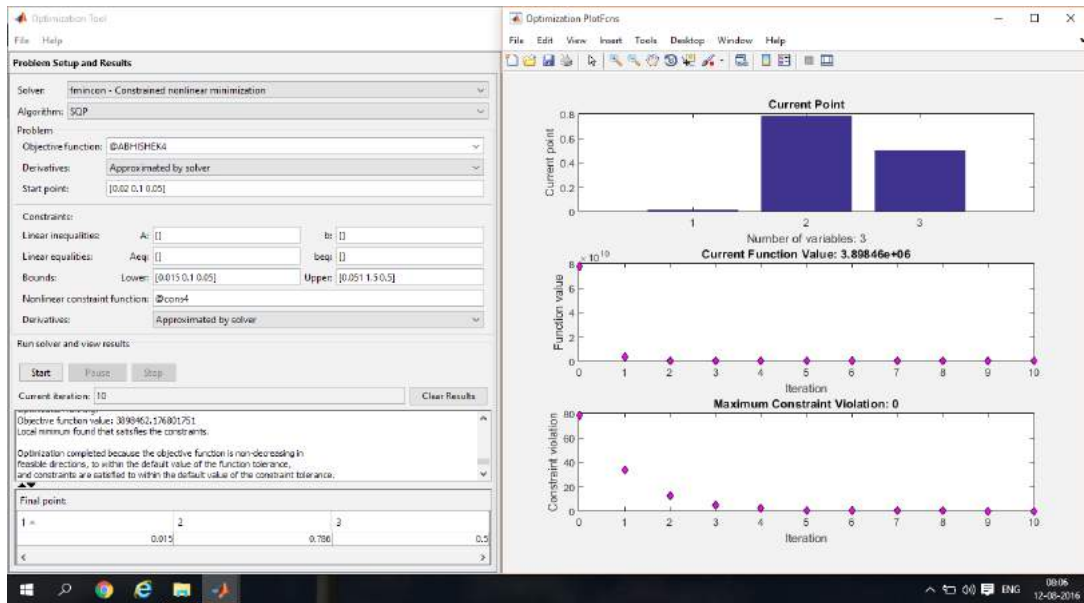

**Fig 4.2:** Results and Graphs of Case Study 1 Starting from Feasible Point by SQP used in Optimization Tool of Matlab

**Table 4.3:** The Process Input and Physical Properties for Case Study 2

Case-2	$m$ (kg/s)	$T_i$ (°C)	$T_o$ (°C)	$\rho$ (kg/ m <sup>3</sup> )	$C_p$ (kJ/kg)	$\mu$ (Pa-s)	$k$ (W/mK)	$R_f$ (m <sup>2</sup> K/W)
Shell side: distilled water	22.07	33.9	29.4	995	4.18	0.00080	0.62	0.00017
Tube side: raw water	35.31	23.9	26.7	999	4.18	0.00092	0.62	0.00017

**Table 4.4:** Parameters of the optimal shell and tube heat exchangers for case study 2 using different optimization methods

Parameters	Literature[4]	GA[5]	PSO[10]	ICA[11]	SQP[present work]
do (m)	0.019	0.016	0.0145	0.015	0.015
Ds (m)	0.387	0.62	0.59	0.66	0.576
B (m)	0.305	0.440	0.423	0.5	0.5
L (m)	4.880	1.548	1.45	1.467	1.717
Pt (m)	0.023	0.020	0.0181	0.01875	0.0187
Cl (m)	0.004	0.004	0.0036	0.00375	0.0037
De (m)	0.013	0.015	0.0103	0.011	0.0107
Nt	160	803	894	897	781

Parameters	Literature[4]	GA[5]	PSO[10]	ICA[11]	SQP[present work]
vt (m/s)	1.76	0.68	0.74	0.745	0.8001
Ret	36409	9487	9424	10390	10425
Prt	6.2	6.2	6.2	6.2	6.2
ht (W/m2K)	6558	6043	5618	5412	4489.8
ft	0.023	0.031	0.0314	0.031	0.0311
$\Delta Pt$ (Pa)	62812	3673	4474	3497	4442
as (m2)	0.0236	0.0541	0.059	0.0657	0.0576
vs (m/s)	0.94	0.41	0.375	0.36	0.3851
Res	16200	8039	4814	5130	10059
Prs	5.4	5.4	5.4	5.4	5.4
hs (W/m2K)	5735	3476	4088.3	5239	6337.9
fs	0.337	0.374	0.403	0.3998	0.3614
$\Delta Ps$ (Pa)	67684	4365	4721	4696	5022.9
U (W/m2K)	1471	1121	1177	1243	1221.5
S (m2)	46.6	62.5	59.15	62.05	63.163
Ci (Rs)	1241175	1437225	1396050	1431975	1378230
Co (Rs/year)	334950	20400	20700	20475	21121.515
Cod (Rs)	2058000	125325	127200	125925	129780
Ctot (Rs)	3299175	1562550	1523250	1557900	1508010

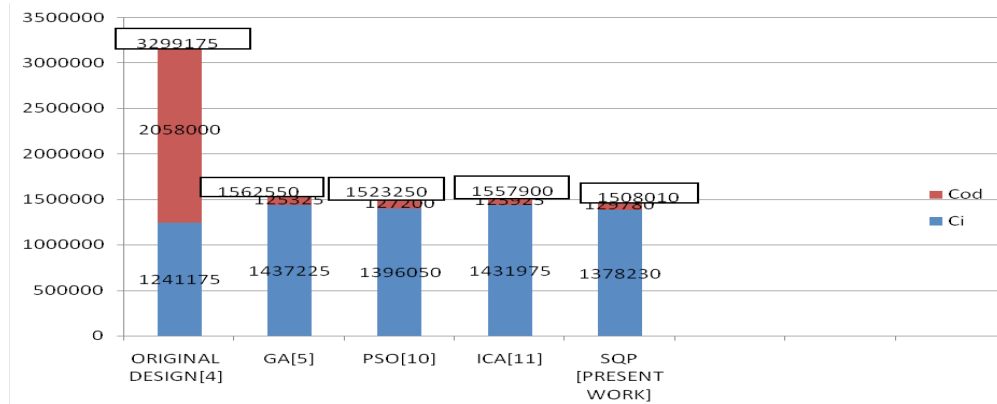

**Fig 4.3:** Cost Comparison for Case Study 2

The figure shows results and graphs of case study 2 by SQP used in optimization tool of Matlab. It may be observed that the objective function converges within 9 iterations for case 2. The first graph shows the optimization variables values, second graphs shows the optimization function value with respect to the iterations and third graph shows maximum

constraint violation with respect to the iterations.

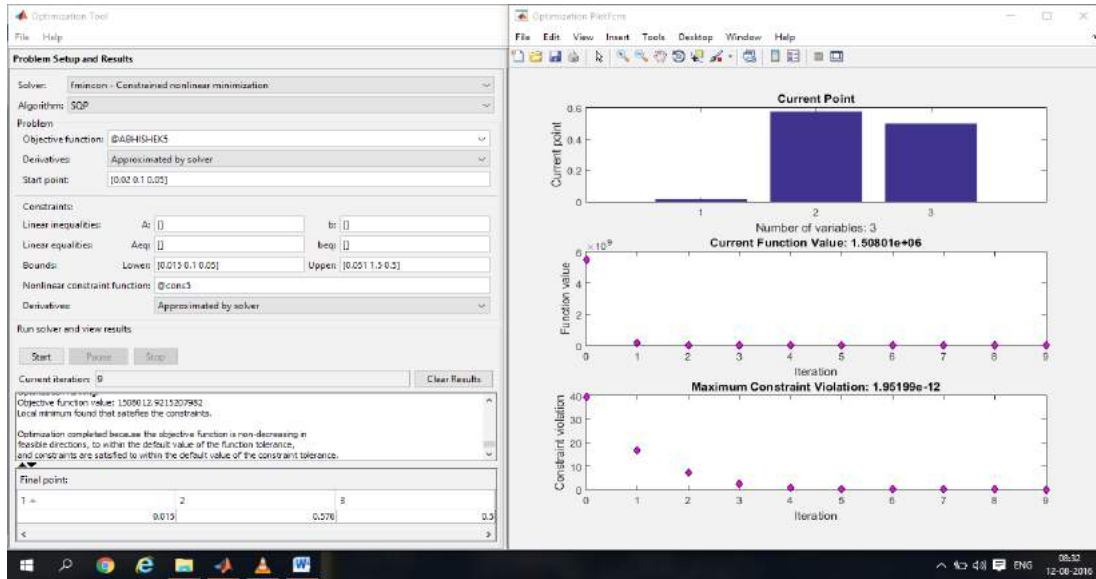

Fig 4.4: Results and graphs of case study 2 starting from feasible point by SQP used in Optimization tool of Matlab

**CONCLUSIONS AND FUTURE SCOPES**

Identifying the best and cheapest heat exchanger for a specific heat duty is a tough decision making task. The present work focuses upon total cost minimization of shell and tube type heat exchanger. The total cost includes capital investment cost and discounted operating cost. The design variables tube diameter, shell diameter and baffle spacing along with bounds and a nonlinear constraint have been considered. The resulting optimization problem has been solved using sequential quadratic programming (SQP) algorithm, which is simple and easy for implementation.

A code has been implemented in Matlab for optimization purposes. Two cases are considered from previous literatures. The code developed in present work using SQP converges to optimum value of the objective function within quite few iterations. This feature signifies the importance of SQP. In each case study, starting point may either be feasible or infeasible, optimization problem converges to same optima.

CASE STUDY1: lower bound = [0.015 0.1 0.05] and upper bound = [0.051 1.5 0.5]

Starting Point	Final Point	Improvement In Total Cost With Respect To			
FEASIBLE POINT [0.02 0.2 0.1]	[0.015 0.786 0.5]	ORIGINAL DESIGN[3]	GA[5]	PSO[10]	ICA[11]
INFEASIBLE POINT [0.01 0.2 0.1]	[0.015 0.786 0.5]	19.38%	5.62%	2.35%	4.389%

CASE STUDY 2: lower bound = [0.015 0.1 0.05] and upper bound = [0.051 1.5 0.5]

<i>Starting Point</i>	<i>Final Point</i>	<i>Improvement In Total Cost With Respect To</i>			
Feasible Point [0.02 0.2 0.1]	[0.015 0.576 0.5]	Original Design[4]	GA[5]	PSO[10]	ICA[11]
Infeasible Point [0.01 0.2 0.1]	[0.015 0.576 0.5]	54.291%	3.49%	1.00%	3.202%

It may be concluded that total cost of a shell and tube type heat exchanger is decreased by using SQP in each case study and the obtained results show improvement as compare to those presented in previous literatures. In present work, the total cost of shell and tube type heat exchanger is optimized considering three design variables, two tube side passages and one shell side passage using SQP. In future, number of design variables such as length, pitch, tube side passages and shell side passages may be increased, for the optimization of total cost. Further, the algorithm used in present work may also be utilised in some other applications like in maximizing the total revenue by a hydroelectric power plant.

## REFERENCES

- [1] Srivastava AK, Dubey VVP, Verma RR, Verma PS, Shell & Tube Type Heat Exchangers: An Overview IJRAME ISSN (ONLINE): 2321-3051.
- [2] Shah RK and Sekulib DR, University Of Kentucky, Heat exchanger classification.
- [3] Sinnott RK, Coulson and Richardson's chemical engineering, chemical engineering design. vol. 6. Butterworth-Heinemann; 2005.
- [4] Kern DQ, Process heat transfer. New York: McGraw-Hill; 1950.
- [5] Caputo AC, Pelagagge PM, Salini P, Heat exchanger design based on economic optimization. Appl Therm Eng 2008;28:1151–9.
- [6] Taal M, Bulatov I, Klemes J, Stehlik P, Cost estimation and energy price forecast for economic evaluation of retrofit projects. Appl Therm Eng 2003;23: 1819–35.
- [7] Peters MS, Timmerhaus KD, Plant design and economics for chemical engineers. New York: McGraw-Hill; 1991.
- [8] Gill E. Philip, Jayb O. Laurent, Leonardc W. Michael, Petzoldd R. Linda , Sharmad V, An SQP method for the optimal control of large-scale dynamical systems, Journal of Computational and Applied Mathematics 120 (2000) 197–213.
- [9] Gill E. Philip, WONG E, Sequential Quadratic Programming Methods, UCSD Department of Mathematics Technical Report NA-10-03 August 2010.
- [10] Patel VK, Rao RV, Design optimization of shell-and-tube heat exchanger using particle swarm optimization technique. Appl Therm Eng 2010;30:1417–25.
- [11] Hadidi A., Hadidi M. and Nazari A, A new approach for shell and tube heat exchangers using imperialist competitive algorithm, energy conversion and management 67 (2013) 66-74.

# Bandwidth Improvement of Corner Truncated Square Shaped Patch Antenna Using Slots

DHANANJAY SINGH<sup>1</sup> AND AMBICA YADAV<sup>2</sup>

## Abstract

*The conventional Rectangular Microstrip patch antenna has very narrow impedance bandwidth, typically of few percent. While Microstrip patch antenna have the advantage of low cost, thin profile, light weight, ease of fabrication, conformable to mounting surface and being integrated in active devices. This paper introduces geometry of corner truncated square shape MPA (Microstrip Patch Antenna) results in increase in Bandwidth from 3.227% to 9.634%. The geometry of slotted and corner truncated square shape MPA is designed on a FR4 substrate with a dielectric constant and tangent loss of 4.4 and 0.025 respectively.*

**Keywords:** *Bandwidth, Rectangular Microstrip Patch Antenna, Slotted Rectangular Microstrip Patch Antenna, Return Loss, Coaxial Probe Feed, 2D Radiation Pattern.*

## INTRODUCTION

The conventional Rectangular MPA has very narrow impedance bandwidth, typically of few percent [1]. While Microstrip patch antenna have the advantage of low cost, thin profile, light weight, ease of fabrication, conformable to mounting surface and being integrated in active devices [2]. Also Coaxial probe fed microstrip antennas provide excellent isolation between the feed network and the radiating elements and yield very good front to back ratios [2]. Due to this many advantages the rectangular microstrip patch antennas have many applications like space technology, aircrafts, missiles, tracking, mobile communication, GPS systems, remote sensing and satellite broadcast [3][4]. The most important drawback of microstrip patch antenna is narrow bandwidth. Maximum 8% bandwidths are available with classical microstrip antennas. To overcome this drawback, one of the methods is to cut slots in various shapes. For example, by cutting slits the bandwidth was increased to 2 times [6], by embedding U-slots in stacked patch the bandwidth was improved to 2 times as compared to the conventional Rectangular MPA [2]. And also the wideband characteristics of the antenna is achieved by using the L-shaped probe feeding techniques, the use of series slots (H-shaped) and another pair of parallel slots (E-shaped) lead to the

---

<sup>1</sup> Electronics and Communication Department, Mangalmay Institute of Technology, Greater Noida, (U.P.)

E-mail: Dhananjay1987yadav@gmail.com

<sup>2</sup> Electronics and Communication Department, SRMSCET, Bareilly, (U.P.)

E-mail: ambica456yadav@gmail.com

improvement of bandwidth of 21.79% [7]. So, by embedding suitable slots in the radiating patch, compact operation with enhanced impedance bandwidth can be obtained [5].

In this study, the properties of traditionally Rectangular MPA and Slotted Rectangular MPA with a pin short are presented and compared to each other. The designs were simulated using electromagnetic simulator, Zealand IE3D software. It was found that for the extension of bandwidth, slot can be embedded on the patch.

### ANTENNA DESIGN

The conventional square patch microstrip antenna is considered the reference antenna to compare the results of that obtained from corner truncation of slotted antenna. The geometry of the conventional square MPA is shown in Figure 1. The patch has the dimension of  $L \times W = (20\text{mm} \times 20\text{mm})$  and is printed on FR4 of dielectric constant,  $\epsilon_r = 4.4$  and the thickness of the substrate,  $h = 1.59\text{ mm}$ . A coaxial probe is used to connect the microstrip patch at coordinates (0mm, 6mm) and it is made fixed for both the conventional and the modified Rectangular MPA.

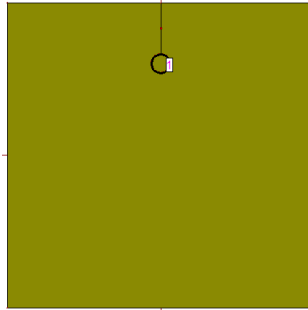

**Figure 1:** Square MPA of  $a=20\text{mm}$

The geometry of the proposed to extend the bandwidth probe-fed patch antenna with embedding slot is shown in Fig. 2. Impedance bandwidth of about 9.63% can be obtained from the below geometry. The main advantage of this structure is that it produces wider bandwidth than the conventional Square patch.

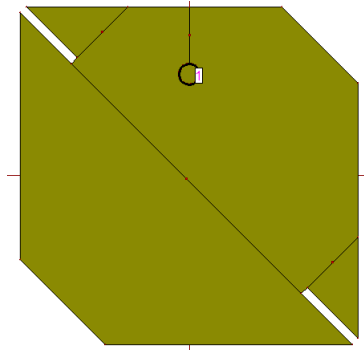

**Figure 2:** Corner truncated and slotted MPA

**SIMULATED RESULTS**

*A. Radiation Pattern*

A radiation pattern defines the variation of the power radiated by an antenna as a function of the direction away from the antenna. This power variation as a function of the arrival angle is observed in the antenna’s far field.

The microstrip antenna radiates normal to its patch surface. So, the elevation pattern for  $\phi=0$  and  $\phi=90$  degrees are important for the measurement. The simulated E-plane and H-plane pattern, 2D pattern view the conventional square patch and the modified square patch are illustrated in Fig. 3(a) and 3(b).

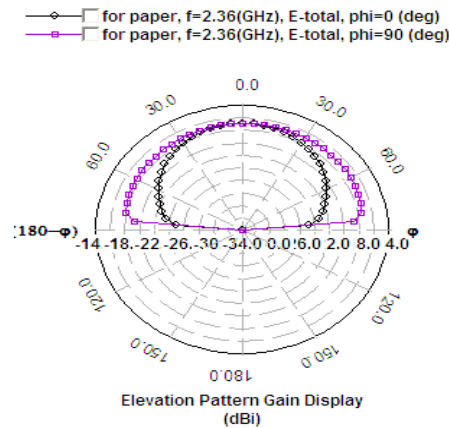

**Figure 3 (a):** 2D Radiation Pattern for square MPA

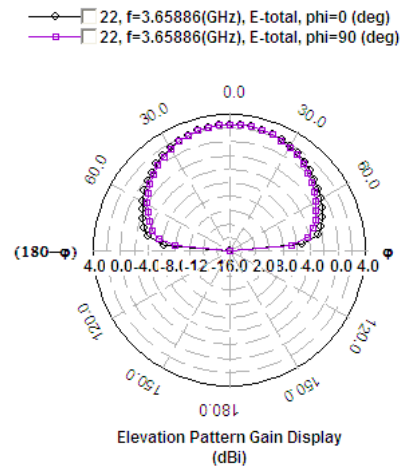
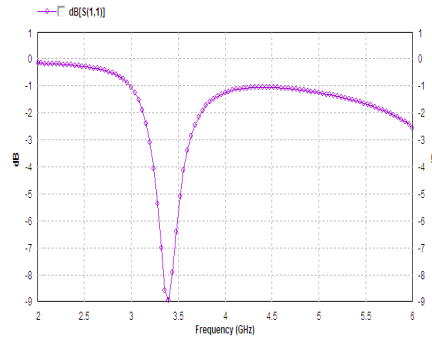

**Figure 3 (b):** 2D Radiation Pattern for corner truncated and slotted square MPA



*B. Return Loss and Bandwidth:*

The Return Loss shown in Fig. 4(a) of the square MPA is -8.90 dB at Resonating frequency at 3.395 GHz.



**Figure 4 (a):** Simulated Return Loss for Square MPA

The Return Loss shown in Fig.4 (b) of the modified square MPA is -29.82dB at Resonating frequency at 3.65GHz and the bandwidth obtained is 9.63%.

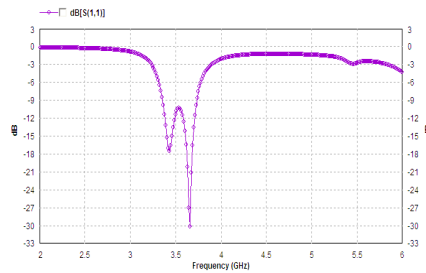

**Figure 4 (b):** Simulated Return Loss for corner truncated and slotted square MPA

*C. Smith Chart*

The loops in the Smith Chart show where the antenna and feed structure were resonant and the nearer the loop to the centre of the chart the better the impedance match. Smith Chart also provides the information about polarization. The Smith chart for the conventional square MPA is given in Fig.5 (a).

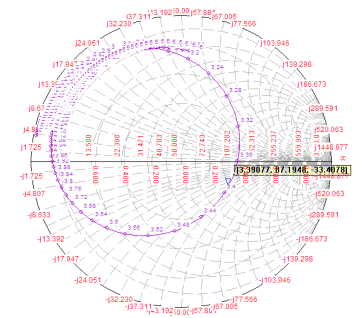

**Figure 5 (a):** Smith Chart for square MPA

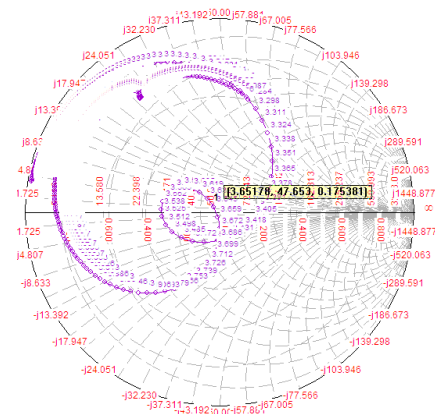

Figure 5 (b): Smith Chart for Modified Rectangular MPA

## CONCLUSION

In this paper, the new geometry proposed the better bandwidth of 9.63% was achieved by truncating corner and digging slots in the antenna design. There is also improvement in return loss. The radiation pattern of the antenna was stable over the entire bandwidth.

## REFERENCES

- [1] H. Wang, X. B. Huang, and D. G. Fang, "A Single Layer Wideband U-Slot Microstrip Patch Antenna Array," *IEEE Antennas and Wireless Propagation Letters*, VOL. 7, 2008.
- [2] Koray Surmeli, Bahattin Turetken, "U-Slot Stacked Patch Antenna Using High and Low Dielectric Constant Material Combinations in S-Band," *Antenna Test and Research Center (ATAM)*.
- [3] Ramesh Garg, PrakashBhartia, Inder Bahl, ApisakIttipiboon, "Microstrip Antenna Design Handbook," Artech House Publications, Boston, London.
- [4] Constantine A. Balanis, "Antenna Theory Analysis and Design," *Third Edition*, Wiley Publication.
- [5] Kin-Lu Wong, "Compact and Broadband Microstrip Antennas," Wiley Publication, 2002.
- [6] Soliman A. Shetawy, Prof. Esmat A. Abdallah, Prof. Darwish Abdel-Aziz, "Slotted Ground Plane of Rectangular Patch Microstrip Antenna with Enhanced Bandwidth and Size Reduction," *12<sup>th</sup> WSEAS International Conference on Communication*, Heraklion, Greece, July 23-25, 2008.
- [7] Mohammad Taroqul Islam, Mohammad NazmusShakib, Norbahiah Misran, Tiang Sew Sun, "Broadband Microstrip Patch Antenna," *European Journal of Scientific Research*, VOL. 27 No.2 (2009), pp.174-180.

# A Survey on IoT Based Water Quality Monitoring System

APOORVA SHARMA<sup>1</sup> AND PANKAJ SHARMA<sup>2</sup>

## Abstract

*Water is the most precious and valuable for all the human beings. Many countries have serious issues related to water quality deterioration and water pollution due to growing population and ageing infrastructure. To fortify the supply of drinking water the quality should be monitored in real time, for that new approach IOT (Internet of Things) based water quality monitoring has been proposed. In this report, a design and development of low cost system for real time water quality monitoring system in IOT is presented. Internet of things is a global network of smart devices which have sensors and that can also interact with their environment using internet. In IOT technology, devices are integrated with the virtual world of internet and communicate the data with it by tracing, monitoring and sensing the objects and environment. To monitor the water quality, IOT system consists of several sensors that are used to measure the physical and chemical parameters of water. The parameters such as temperature, PH, turbidity, conductivity, dissolved oxygen of the water can be measured. To automate this process, water quality monitoring sensors, raspberry pi, ZigBee protocol and data concentrator module are physically placed in every water sources. The water quality monitoring sensors gather data from water, and forward that data to raspberry pi for binary to digital conversion. The raspberry pi forward that data to concentrator module through ZigBee module for remote transfer of data to the lab, then data concentrator send that data to the cloud server which is in the testing laboratory. Parameter data stored in the cloud can be securely provided to requested users.*

**Keywords:** *Turbidity, Conductivity, Zigbee, Raspberry pi, Microcontroller*

## INTRODUCTION

The restricted and extremely important resource for industries, agriculture, and all the creatures prevailing on the earth including human being is water. Any imbalance in water quality would severely exert influence on the health of the humans, animals and have an impact on the ecological balance among species [5]. The WHO (world health organization) estimated, in India among 77 million human beings are enduring agony due to not having safe water. Reckon of WHO is that 21% of malady and wog is related to unsafe water in India. Also, more than 1600 deaths alone cause due to diarrhea in India daily. In the 21st century there were lots of inventions, but at that time were pollutions, global warming

---

<sup>1</sup> M.Tech Student Assistant Professor, Department of Computer Science & Engineering

<sup>2</sup> School of Computer Science and Engineering Galgotias University, Greater Noida, U.P.

and so on are also being formed, because of this there is no safe drinking water for the world's population [1]. Therefore, nowadays water quality monitoring in real time is major concern due to global warming, pollution and growing population. Various water quality criterion such as dissolved oxygen (DO), conductivity of water, pH, turbidity and temperature should be monitored in real time to ensure the safe supply of drinking water. The water quality parameter pH show water is acidic or basic, the dissolved oxygen (DO) is indicated the oxygen that dissolved in water and It makes the drinking water taste better. The conductivity indicates the ability of water to pass an electrical current and in water, it is influenced by various dissolved solids such as chloride, nitrate, sulphate, sodium, calcium, etc. Indication of the degree at which the water loses its transparency is defined as turbidity. It is gauge as a good measure of the quality of water. Water temperature, stipulates how water is hot or cold [3]

In this report a development and design a low-cost water quality monitoring system that can monitor water quality in real time using IOT environment has been proposed. In this proposed system water quality is measured by different water quality sensors such as pH, turbidity, conductivity, dissolved oxygen and temperature. Internet of Things (IoT) is an blended and assimilated part of future internet and it could be expound as a dynamic global network infrastructure with self-configuring knack [4]

As per IOT design, all water parameters are traced and sensed by various sensors. Then these sensor-parameters are processed by microcontroller and theses processed values are sent to the core controller remotely using ZigBee protocol. In the proposed system, IOT module is used to access processed data from the core controller to the cloud. With the help of IOT environment, we can provide facility to access data remotely from all over the world.

## **SURVEY DETAILS**

In the current scenario of iot based water quality monitoring system design ,is proposed inclusive of Arduino micro controller, sensors, zigbee module. Data is sent by Arduino micro controller using sensors through zigbee module which is further collected to the configured cloud server sited in TWAD testing laboratory [1] and is monitored by the department employees for the requested users usage.

Water quality monitoring can be used to protect source waters by identifying pollutant levels and locations in a source water. Water quality surveiling is commonly done multifarious times a year because quality of the water may change with season and with weather events. Water quality can be monitored by measuring physical, chemical, or biological characteristics of the water. Shruti Sridharan et al. [10] addressed in their project about developing an efficient wireless sensor network (WSN) based water quality monitoring system, that examines water quality, an cardinal strand as far as, irrigation, domestic purposes, industries, are pertained.

R.Karthik Kumar et al. [1] investigated Underwater wireless sensor network to monitor the quality of water using wireless sensor network (WSN) technology powered by solar panel. Through WSN which collect variegated data by assorted sensors at the node side

such as pH, Turbidity and oxygen level and are sent to base station. At the base station collected data is displayed as visual and is analysed using different simulation tools.

Daudi S. Simbeye and Shi Feng Yang [2] presuming the design of water quality surveying and control system for aquaculture grounded and constructed on wireless sensor networks and single chip computer technology as a base in the veritable operation. It realizes the monitoring of the water environmental parameters for intensive aquaculture and alarm notification through short message when oversee variables take anomalous values and is suitable for long-term stability under growth conditions thus increasing yield per unit area.

Zulhani Rasin and Mohd Rizal Abdullah [12] proposed implementation of high power Zigbee based WSN for water quality monitoring system with low power consumption and high reliability presented. The high power WSN is useful for the activities in industries to bring in large area scanning such as manufacturing, constructing, mining.

Geethanjali.S, Mekala.M,Deepik [13] presented a narrative water notablility examine organization Zigbee based on wireless sensor network bestowing small power utilization with high reliability.

Peng jiang and Hongbo xia [10] have lodged the Design of water environment system which uses wireless sensor network. This system takes MSP430F1611 main processor for developing the automatic water environment monitoring system

## **REQUIREMENT SPECIFICATIONS**

In the development of the device using internet of things to monitor the water quality includes data acquisition, data transmission, data preservation which is intricate by the integration of the software and hardware, so top pressing matter becomes the excellent architecture of the water quality monitoring system as a composite system. Data acquisition nodes integrate sensors, data processing module and communication module. The system adopts Zigbee based on IEEE 802.15.4 communication protocol. Zigbee is a wireless intercommunication technique that has low transmitting rate and low cost advantages.

The water quality monitoring system uses large number of tiny sensor nodes through wireless self-organizing way. The sensors gets the data in the network includes the PH, water level, water temperature,dissolved oxygen sensor. Zigbee gets the data using the sensors'then examine data, and then uses application software to manage, handle the data and to make decisions to control devices. The real-time data is received through the sensors and by Zigbee module get stored in the database so as to ensure that the users can query any time and further analyze the information.

The Raspberry Pi is a series of credit card-sized single-board computers and is used as a core controller. This design system applies a specialized IOT module for accessing sensor data from core controller to the cloud. Then Raspberry Pi sends the data to the IoT module. The IoT module send the data to internet using cloud computing and to WIFI for accessing mobile devices. Any Raspberry Pi version 1,2 ,3 can be used by the device for receiving the data from sensors and sending it to the IOT module.

## **ZIGBEE PROTOCOL**

ZigBee is a stipulation used by the high-level communication protocols which is used to create personal area networks built from small, very low-power digital radios. ZigBee is rooted on an IEEE 802.15.4. The transmission is limited to the distance 10– 100 meters. The Z specifications of the Zigbee were introduced in December 2004 and the ZigBee network specification is among one of the first standards for ad-hoc and sensor networks [6]. Zigbee protocol is bloomed by the Zigbee Alliance for personal-area networks (PANs). Low cost, low power consumption of the device and the low data rate connectivity devices are used by the Zigbee. The Zigbee stipulation is an open standard which allows the manufacturers to evolve their own specific application which requires low cost and low power with network structure, routing, and security for the communication purpose and is created by the coordinator node which controls the network and specifies a unique address to each device in the network, regardless of its topology [7]. For sending the data for long distance Zigbee devices use a mesh topology. Low data rate, low power consumption of the device, and more node density makes Zigbee suitable for sensor networking in the proposed system [8]. Zigbee does the same work as that Wi-Fi or Bluetooth do but do not provide full duplex that is the both way communication between multi variant devices over a simple network which uses very low power of the device at a very low cost.

## **SENSORS**

A Sensor is an object whose cause is to detect the events occurring or the changes happening in its surroundings and it sends the detected information to the device which then tells the actuator which is the output device to provide the desired output. A sensor is a device that transforms the real world data which is the Analog into the data that a device can understand using Analog to Digital converter (ADC). varieties of sensors are used in day to day to day objects. Output of the sensor change based on the change of the input applied. A good sensor obeys the following rules: sensitivity to the measured property of the device, the insensitivity to any other property of the device likely to be discovered in its application, and it does not affect the measured property. The PH sensor, Temperature and Turbidity sensors are used for examining the water quality and are connected to Raspberry Pi board for gathering water parameters.

## **RASPBERRY PI**

Raspberry PI is the core controller. The Raspberry Pi is totally equipped with a range of drivers which are used for interfacing. However, it's not viable to load each and every driver whenever the system boots, the system resources will be used redundantly as it will increase the boot time of the system majorly. Then Raspberry Pi controller sends data to the IoT module. The IoT module send data using cloud computing and use WIFI for accessing mobile devices.

## **DESIGN DIAGRAMS**

In this defined block diagram of the designed system consist of several sensors temperature,

Ph, turbidity, conductivity of the water, dissolved oxygen is connected to core controller. The core controller are accessing the sensor values and processing them to transfer the data through internet. Raspberry PI is used as a core controller. The sensor data can be viewed on the internet. This proposed block diagram consist number of devices having respective sensors, and the collected data from all devices are gathered at the core controller raspberry pi via Zigbee protocol IEEE802.15.4.

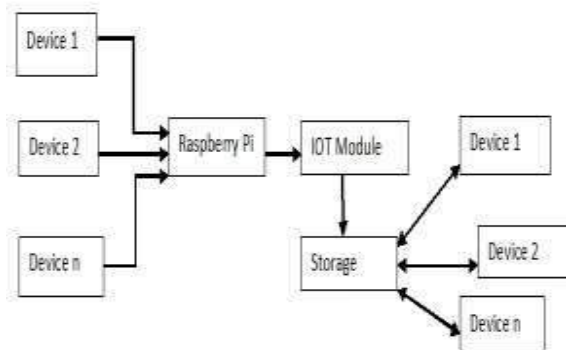

**Figure 1:** Block Diagram of Proposed system

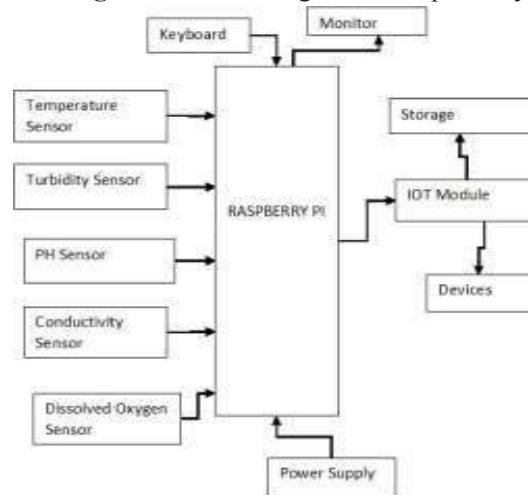

**Figure 2:** Block diagram to monitor water quality

## IMPLEMENTATION

The device consists several sensors for measuring water quality parameter such as pH, turbidity, conductivity, dissolved oxygen, temperature. Raspberry Pi controller gathers the data from the sensors and change that data into digital form and send so as to safely

provide data for user access in the cloud enabled system for analysis. These sensors could be deployed and the collected data will be stored in the cloud storage for further analysis purpose.

So, the microcontroller is introduced in a proposed system for getting data from sensors and processes on them to make compatible for Zigbee module. A Zigbee module consists router Zigbee, which located on all devices that transmit the processed data to the coordinator Zigbee, which collects data from devices connected in the same network. The router Zigbee and coordinator Zigbee are connected in same network using a same PAN ID (personnel area network) for all Zigbee devices in the network. The PAN ID provides the personal area network for wireless data communication for sensor networking. Coordinator Zigbee is connected to the core controller, the core controller manages data coming from different devices [9]. The core controller puts the data in a text file which is transmitted to the IOT module. For transmitting data to the IOT, gateway is created on the raspberry pi using FTP (file transfer protocol) protocol. In the proposed system, for monitor processed data on the internet cloud computing technology is use which provides the personal local server. In cloud computing, separate IP address is provided which make possible to monitor data from anywhere in the world using the internet. To access that monitor data and make system user-friendly browser application is introduced which work on HTTP. So, by using browser application user can access and monitor the data from all over the world.

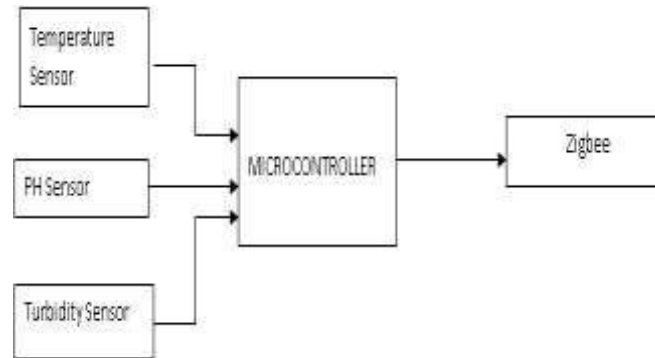

**Figure 3:** Block diagram of the device

## CONCLUSION

Water quality monitoring can be extended by including various other parameters. Location based data can be analysed which is accessed by the user through the cloud computing storage facility. Zigbee module is used to design the monitoring system which consumes low power and is cost efficient. Raspberry pi controller act as a gateway to the whole system. IOT module provides the facility of accessing the data and monitoring and examining data using the cloud computing storage technology from anywhere in this world effectively using internet. Data collected using the gateway is stored, analysed, monitored and viewed using internet by the mobile devices. Chemical parameters exist for examining the water quality further the biological factors too can be included so as to monitor the quality of the water and this data can be further send to the laboratories or the water board.



## REFERENCES

- [1] R.Karthik Kumar, M.Chandra Mohan, S.Vengateshapandiyam, M.Mathan Kumar, R.Eswaran, "Solar based advanced water quality monitoring system using wireless sensor network," International Journal of Science, Engineering and Technology Research (IJSETR), vol. 3, Issue 3, March, pp. 385-389, 2014.
- [2] Daudi S. Simbeye and Shi Feng Yang, "Water Quality Monitoring and Control for Aquaculture Based on Wireless Sensor Networks" - JOURNAL OF NETWORKS, VOL. 9, NO. 4, APRIL 2014.
- [3] Peng Cheng, Xi-Li Wang, "The Design and Implementation of Remote-sensing Water Quality Monitoring System Based on SPOT-5," Second IITA International Conference on Geoscience and Remote Sensing, 2010, pp. 6-10.
- [4] TianrongRao, Qiang Ling, Bin Feng Yu and Haibo Ji, "Estimate the densities of pollutions in water quality monitoring systems based on UV/vis spectrum," 26th Chinese Control and Decision Conference (CCDC), 2014, pp. 2984-2989.
- [5] Aravinda S. Rao, Stephen Marshall, Jayavardhana Gubbi, Marimuthu Palaniswami, Richard Sinnott and Vincent Pettigrove, "Design of Low-cost Autonomous Water Quality Monitoring System," International Conference on Advances in Computing, Communications and Informatics (ICACCI), 2013, pp. 14-19.
- [6] Hu Guozhen, "Key Technologies Analysis Of ZigBee Network Layer," 2nd International Conference on Computer Engineering and Technology, vol. 7, 2010, pp. 560-563.
- [7] LieGuo Wu, Lingcheng Kong and Zhihua Zhang, "Water Environment Monitoring System Based On ZigBee Wireless Sensor Network," Department of Automation, University of Science and Technology of China Institute of Advanced Manufacturing Technology, Hefei, Anhui Province, China, 2013, pp. 898-901.
- [8] R.Nagarajan, Member, IEEE and R.Dhanasekaran, Senior Member, IEEE, "Implementation of Wireless Data Transmission in Monitoring and Control," International conference on Communication and Signal Processing, India, April, 2013, pp. 83-87
- [9] Hao Chen, Xueqin Jia, Heng Li, "A Brief Introduction to IOT Gateway," Proceedings of ICCTA, Network Technology Research Center, China Unicom research Institute, Beijing 100032, China. 2011
- [10] Shruti Sridharan, "Water Quality Monitoring System Using Wireless Sensor Network" - International Journal of Advanced Research in Electronics and Communication Engineering (IJARECE) Volume 3, Issue 4, April 2014.
- [11] Daudi S. Simbeye and Shi Feng Yang, "Water Quality Monitoring and Control for Aquaculture Based on Wireless Sensor Networks" - JOURNAL OF NETWORKS, VOL. 9, NO. 4, APRIL 2014.
- [12] Zulhani Rasin and Mohd Rizal Abdullah, "Water Quality Monitoring System Using Zigbee Based Wireless Sensor Network" - International Journal of Engineering & Technology IJET -IJENS Vol:09 No:10.
- [13] Geethanjali.S, Mekala.M, Deepik, "Water Eminence Scrutinizing Scheme Based On Zigbee and Wireless Antenna Expertise - A Study" - International Journal of scientific Research in Computer Science Applications and Management Studies - ISSN 2319 – 1953.
- [14] Peng Jiang, Zheming Wang, "Design of water environment monitoring system based on wireless sensor network" - IEEE 2nd International Conference on Industrial and Information Systems, 2010.

# The Beneficial Data Storage Technique: RAID

ARVIND KUMAR<sup>1</sup> AND SACHIN KUMAR<sup>2</sup>

## Abstract

*RAID is a technology that is used to increase the performance and/or reliability of data storage. The abbreviation stands for Redundant Array of Inexpensive Disks. A RAID system consists of two or more disks working in parallel. These disks can be hard discs but there is a trend to also use the technology for solid state drives. There are different RAID levels, each optimized for a specific situation. These are not standardized by an industry group or standardisation committee. This explains why companies sometimes come up with their own unique numbers and implementations.*

*This review paper explores the applications of RAID technique which have been developed to support expert data storage management process.*

*In the late 1980s, researchers at the University of California at Berkeley were looking for ways of combining disks into arrays with desirable combinations of affordability, data availability and I/O performance.*

*In 1988, a landmark paper entitled A Case for Redundant Arrays of Inexpensive Disks was published. The paper demonstrated that arrays of low-cost personal computer disks could be effective substitutes for the high capacity, high performance disks then used with data centre computers. Five disk array models, called RAID Levels, were described.*

## INTRODUCTION

**RAID** is a mature technology that speeds up data access while at the same time protecting your data from hard disk failure. **RAID** is quickly becoming a necessary component in every network since data loss and downtime can prove both fatal and financially destructive. Most networks are designed to provide instant access to massive amounts of data. More and more employees have to access customer and other databases. Intranets and corporate Web sites provide access to huge databases online.

The software to perform the RAID-functionality and control the hard disks can either be located on a separate controller card (a hardware RAID controller) or it can simply be a driver. Some versions of Windows, such as Windows Server 2003, as well as Mac OS X include software RAID functionality. Hardware RAID controllers cost more than pure software but they also offer better performance.

---

<sup>1</sup> IIMT College of Engineering, Greater Noida  
E-mail: malik\_arvind1@yahoo.com

<sup>2</sup> IIMT College of Engineering, Greater Noida  
E-mail: 12.sachin@gmail.com

RAID-systems can be based with a number of interfaces, including SCSI, IDE, SATA or FC (fibre channel.) There are systems that use SATA disks internally but that have a FireWire or SCSI-interface for the host system.

Sometimes disks in a RAID system are defined as JBOD, which stands for '*Just a Bunch Of Disks*'. This means that those disks do not use a specific RAID level and acts as stand-alone disks. This is often done for drives that contain swap files or spooling data.

## RAID COMPONENTS AND CONCEPTS

First, let us define *Logical Arrays* as a split or combination of *Physical Arrays*, which in turn are one or more Physical Drives that are simply the individual hard disks that comprise these arrays.

*Logical Drives* are then made of one or more Logical Arrays.

*Mirroring* refers to complete redundancy of data on identical disks. The data that is being written on one Logical Array is completely duplicated on a similar array thereby providing 100% data redundancy. The cost associated with mirroring is that the amount of available storage is reduced by 50%; writes are slightly slower albeit reads are faster in some situations.

*Striping* refers to a technique that allows Physical Drives in a Logical Array to be used in parallel in order to gain in performance. In this technique, data is broken down in Byte or Block levels or stripes, where every Byte or Block is written to a separate disk in the array. Byte level can at times be a 512-byte sector, while Block size can be selected from variety of choices. The gain in performance is similar between Reads and Writes.

In some RAID levels, striping is combined with a technique called Parity to enhance fault tolerance. Parity, similar to parity in memory, is simply adding a Block (Byte) of calculated parity data to several Blocks (Bytes) in such a way that any one of the Blocks (Bytes) can be reconstructed in case of loss, from the remainder of the Blocks (Bytes) and the parity Block (Byte). While Parity gains from performance of striping, its disadvantages are more complexity and loss of some disk space, which is taken up by parity information. There are many ways to combine RAID techniques.

Some standardized combinations are referred to as RAID Levels, even though 'Level' in this context does not denote any hierarchy or advantage. Levels are independent and different. Some RAID levels combine multiple other levels to achieve certain aims.

The RAID Advisory Board (RAB) has been active since 1992 in education and standardization of RAID technology. See <http://www.raid-advisory.com/>. Techniques discussed above are used in different levels. Mirroring is used in levels 1, 0+1, 10 (1+0). Striping without parity is used in level 0, 0+1, and 10. Striping with Block level parity is used in level 5 and 6. While the minimum number of drives required at each level are noted, there is no inherent maximum to number of drives in arrays other than the one imposed by controllers.

## BENEFITS OF RAID

RAID provides increased storage capacities, and protects your important data from hard drive failure.

There are multiple benefits of using RAID:

- Reliability and Scalability.
- Real-time data recovery with uninterrupted access when a hard drive fails.
- System uptime and network availability and protection from loss.
- Protection against data loss.
- Multiple drives working together increase system performance A disk system with RAID capability can protect its data and provide on-line, immediate access to its data, despite a single disk failure (some RAID storage systems can withstand two concurrent disk failures).

RAID capability also provides for the on-line reconstruction of the contents of a failed disk to a replacement disk. RAID offers faster hard drive performance and nearly complete data safety. Storage requirements are expanding as file sizes get bigger and rendering needs get more complex. If you handle very large images or work on audio and video files, faster data throughput means enhanced productivity. RAID can be backed up to tape while the system is in use.

## RAID LEVELS

### RAID level 0 – Striping

In a RAID 0 system data are split up in blocks that get written across all the drives in the array. By using multiple disks (at least 2) at the same time, this offers superior I/O performance. This performance can be enhanced further by using multiple controllers, ideally one controller per disk.

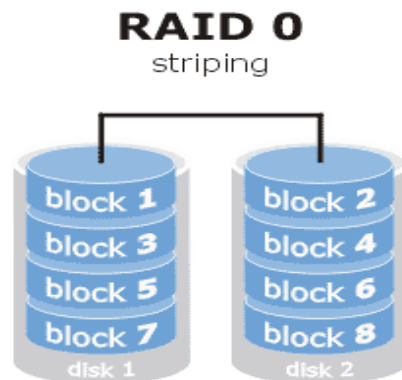

**Advantages**

- RAID 0 offers great performance, both in read and writes operations. There is no overhead caused by parity controls.
- All storage capacity is used, there is no disk overhead.
- The technology is easy to implement.

**Disadvantages**

RAID 0 is not fault-tolerant. If one disk fails, all data in the RAID 0 array are lost. It should not be used on mission-critical systems.

**Ideal use**

RAID 0 is ideal for non-critical storage of data that have to be read/written at a high speed, such as on a Photoshop image retouching station.

**RAID level 1 – Mirroring**

Data are stored twice by writing them to both the data disk (or set of data disks) and a mirror disk (or set of disks) . If a disk fails, the controller uses either the data drive or the mirror drive for data recovery and continues operation. You need at least 2 disks for a RAID 1 array.

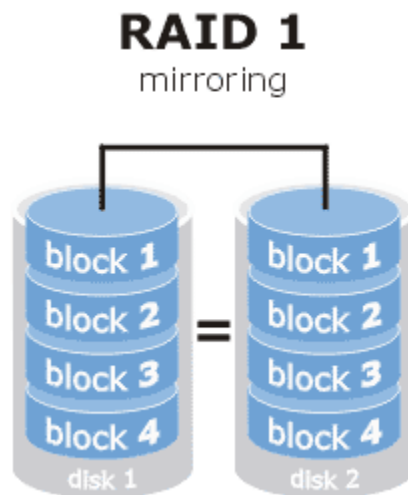

RAID 1 systems are often combined with RAID 0 to improve performance. Such a system is sometimes referred to by the combined number: a RAID 10 system.

**Advantages**

- RAID 1 offers excellent read speed and a write-speed that is comparable to that of a single disk.

- In case a disk fails, data do not have to be rebuilding, they just have to be copied to the replacement disk.
- RAID 1 is a very simple technology.

### Disadvantages

- The main disadvantage is that the effective storage capacity is only half of the total disk capacity because all data get written twice.
- Software RAID 1 solution do not always allow a hot swap of a failed disk (meaning it cannot be replaced while the server keeps running). Ideally a hardware controller is used.

### Ideal use

RAID-1 is ideal for mission critical storage, for instance for accounting systems. It is also suitable for small servers in which only two disks will be used.

### RAID

On RAID 3 systems, data blocks are subdivided (striped) and written in parallel on two or more drives. An additional drive stores parity information. You need at least 3 disks for a RAID 3 array.

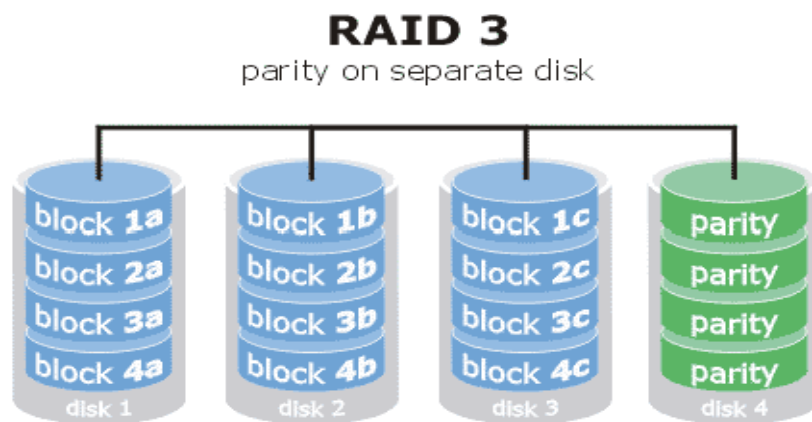

Since parity is used, a RAID 3 stripe set can withstand a single disk failure without losing data or access to data.

### Advantages

- RAID-3 provides high throughput (both read and write) for large data transfers.
- Disk failures do not significantly slow down throughput.

**Disadvantages**

- This technology is fairly complex and too resource intensive to be done in software.
- Performance is slower for random, small I/O operations.

**Ideal use**

RAID 3 is not that common in prepress.

**RAID level 5**

RAID 5 is the most common secure RAID level. It is similar to RAID-3 except that data are transferred to disks by independent read and write operations (not in parallel). The data chunks that are written are also larger. Instead of a dedicated parity disk, parity information is spread across all the drives. You need at least 3 disks for a RAID 5 array. A RAID 5 array can withstand a single disk failure without losing data or access to data. Although RAID 5 can be achieved in software, a hardware controller is recommended. Often extra cache memory is used on these controllers to improve the write performance.

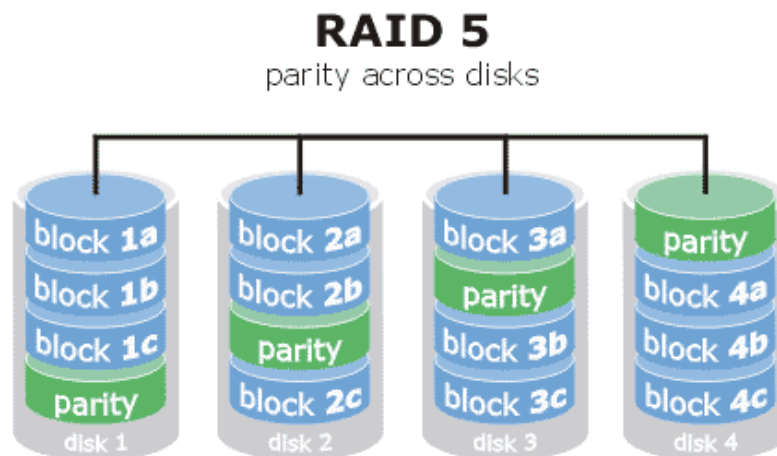
**Advantages**

Read data transactions are very fast while write data transaction are somewhat slower (due to the parity that has to be calculated).

**Disadvantages**

- Disk failures have an effect on throughput, although this is still acceptable.
- Like RAID 3, this is complex technology.

**Ideal use**

RAID 5 is a good all-round system that combines efficient storage with excellent security and decent performance. It is ideal for file and application servers.

### RAID level 10 – Combining RAID 0 & RAID 1

RAID 10 combines the advantages (and disadvantages) of RAID 0 and RAID 1 in one single system. It provides security by mirroring all data on a secondary set of disks (disk 3 and 4 in the drawing below) while using striping across each set of disks to speed up data transfers.

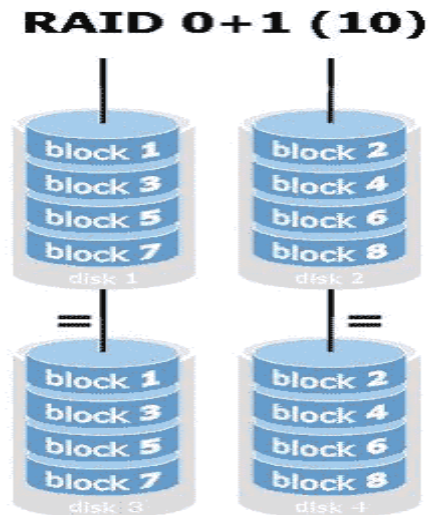

### What about RAID levels 2, 4, 6 and 7?

These levels do exist but are not that common, at least not in prepress environments. This is just a simple introduction to RAID-system.

### RAID is no substitute for back-up!

All RAID levels except RAID 0 offer protection from a single drive failure. A RAID 6 system even survives 2 disks dying simultaneously. For complete security you do still need to back-up the data from a RAID system.

- That back-up will come in handy if all drives fail simultaneously because of a power spike.
- It is a safeguard if the storage system gets stolen.
- Back-ups can be kept off-site at a different location. This can come in handy if a natural disaster or fire destroys your workplace.
- The most important reason to back-up multiple generations of data is user error. If someone accidentally deletes some important data and this goes unnoticed for several hours, days or weeks, a good set of back-ups ensure you can still retrieve those files.



### Where can I use RAID?

- LANs/WANs.
- SANs.
- Clustering environments.
- Mission critical installations.
- News centres.
- Internet News Servers.
- Enterprise Servers.
- Performance Desktop Systems.
- PC Workstations.
- Workgroup/File Servers.
- E-Mail Servers.
- Intranet/Web Servers.
- Application Servers.

### IMPLEMENTING RAID

#### Types of RAID Array Subsystems

Although they can be hardware assisted, both redundant check data and data striping are essentially system software technologies. The *control software* that implements RAID algorithms can execute either in host computers or in disk controllers. Today, RAID array subsystems are available in three basic forms:

- **Host based.** The *control software* for host based RAID subsystems executes in the computer(s) to which the virtual disks are being presented. It is usually bundled with an operating system or sold as part of a volume manager. The hardware components of host based RAID subsystems are disks and host bus adapters.
- **Embedded controller based.** The *control software* for these RAID subsystems executes in processors on dedicated disk controller modules that connect to host computers' internal I/O buses (usually PCI) and emit one or more Fibre Channel, SCSI, or ATA buses to which disks are connected.
- **External "bridge" controllers.** The *control software* for these RAID subsystems also executes in dedicated disk controller which is external to the computer(s) it supports. External RAID controllers typically use Fibre Channel or SCSI buses to attach to host computers and separate Fibre Channel or SCSI buses to attach disks. External RAID controllers can support multiple host computers, and usually scale to support more disks than the other types.

The question of which type of RAID subsystem is the "right" one in any given situation is complex, especially in light of the wide range of RAID subsystem products on the market. As a general rule of thumb, host-based RAID:

- Has the lowest hardware entry cost, and the lowest incremental hardware cost.

- Offers the highest growth potential, because most servers are capable of connecting more disks than most RAID controllers (there are exceptions).
- Runs faster with faster server processors because the server processor executes the RAID algorithms.
- Is more resilient in large systems, both because there are fewer components to fail, and because it is more likely to be closely coupled with highly available volume management and clustering software. Controller-based RAID, on the other hand, has the following advantages:
  - Is likely to perform better in parity RAID configurations, mostly due to write-back cache.
  - Is more nearly host operating system independent, at least in external controller configurations, and therefore more likely to be redeploy able.
  - Is less likely to impact server performance, especially in parity RAID configurations, because RAID algorithms execute on a separate processor.

### What RAID Doesn't Do

While it's not perfect, RAID, including mirroring, does reduce the probability of online data loss significantly. Odds of one in 2,500 aren't bad. But the foregoing discussion has focused entirely on disk failures. There are several other storage subsystem components that can fail with disastrous consequences, even if RAID is in use.

- **Disk buses, host bus adapters, and interface ASICs.** If any of these components fails, it becomes impossible to communicate with any of the disks on the bus. If all arrays in the subsystem are configured so that only one disk from any array is attached to a given bus, then these failures are survivable. If not, bus failure can result in unavailable data (but probably not permanently *lost* data if there are no disk failures).
- **Power and cooling subsystems.** A failed power supply makes all the disks it serves inaccessible. A failed cooling fan eventually results in destruction of all the disks it cools. In most instances it is prohibitively expensive to equip each disk with its own power supply and cooling device (although this has been done). More commonly, power supplies and fans are configured in redundant pairs, with two units serving a set of eight to ten disks. The capacities of the power and cooling units are such that one can adequately power or cool the entire load in the event of failure of the other.
- **External controllers.** Failure of an external controller makes all the disks connected to it inaccessible, and is generally regarded as unacceptable. Most external controllers are sold, or at least can be configured, in pairs connected to the same disks and host computers. When all components are functioning, the controllers in a pair usually share the load—some disks are assigned to one, and others to the other. When a controller fails, its partner takes control of all disks and executes all host requests.

- **Embedded controllers.** From an I/O standpoint, failure of an embedded controller is equivalent to failure of the computer in which it is embedded. Several embedded controller vendors have devised solutions that cooperate with high availability operating systems to fail over disks and arrays from one controller and host to a second controller and host.
- **Host computers.** Except in the case of host based RAID, a host failure is not precisely a failure of the I/O subsystem. Increasingly, however, it is business requirement that applications resume immediately after a host computer failure. This need has given rise to clusters of computers that are connected to the same disks, and are capable of “backing each other up,” with a designated survivor taking over for a failed computer. This has slightly different impact on different types of RAID subsystems. Host based RAID software and embedded RAID controllers must be able to take control of a failed computer’s disks, verify that disk arrays’ contents are self-consistent, and present those arrays through an alternate computer. External RAID controllers must be able to present virtual disks to alternate host computers on command (there is usually no array consistency issue with external controllers in the case of a host failure).
- **Humans and applications.** RAID technology stores and retrieves data reliably, regardless of the data’s content. It is sometimes observed that a RAID array subsystem writes wrong data just as reliably as it writes correct data. RAID therefore does not protect against corruption of data due to human errors or application faults. A combination of high-integrity data managers (e.g., journaling file systems or databases) and a well-designed program of regular backups of critical are the only protections against these sources of data loss.

This short list of other possible disk subsystem failure modes points out why RAID by itself should not be regarded as a complete high availability data access solution. As consumers have become more sophisticated, they have learned that protection against disk failure is necessary, but not sufficient for non-stop data center operation. The entire I/O subsystem, as well as host computers and applications must be protected against equipment failures. RAID is only one building block in a highly available data processing solution.

#### **SUMMARY: WHY IS RAID IMPORTANT?**

As the storage industry becomes increasingly independent of the computer system industry, storage alternatives are becoming more complex. System administrators, as well as managers who make storage purchase and configuration decisions need to understand on-line storage alternatives. Awareness of what RAID can and cannot do for them helps managers make informed decisions about on-line storage alternatives.

Users of networked personal computers may also be concerned about the quality of the storage service provided by their data servers. The material in this paper can help make the personal computer user aware of the significance of available storage alternatives.

Moreover, the first desktop RAID systems have already appeared on the market. As disk size and cost continue to decline, widespread use of RAID on the desktop is only a matter of time.

The purpose of this paper has been to provide the background to help users formulate storage subsystem strategies, particularly with respect to RAID subsystems. The market's view has progressed from RAID as "add-on extra," through RAID as "necessity in mission-critical applications," to "RAID unless there's a good reason not to." In 1997, according to one analyst, about 80% of the disk subsystems shipped was RAID-capable. The analyst predicted RAID ubiquity by the year 2000. It appears that even today, the average server disk is part of a RAID array; non-arrayed disks are the exception rather than the rule.

## **REFERENCES**

- [1] "Raid for Enterprises Computing": Veritas Technology's White Paper.
- [2] "Raid Explained": By Jerry Scott.
- [3] "Raid Levels 0,1,2,3": By Google Inc.

# Real Time Tracking and Monitoring System for any Mobile Applications

BASANTA MAHATO<sup>1</sup>

## Abstract

*A real time tracking and monitoring unit is a revolutionary thing in security of people, developed in this field but this is Real Time Monitoring Unit (RTMU) modify form of all the technology because till now we can use tracking unit in vehicle only but we can use RTMU in all the security place with eco-friendly as well as easily operated by user.*

*RTMU is totally operated on user control and easily send data and store data as per requirement. This paper is proposed to design a Real time Tracking and Monitoring Unit using GPS and GSM technology, which cheapest source of tracking and it would work as anti-theft system. Microcontroller based tracking and monitoring system has been investigated in this paper, whose hardware boards use 8-bit RISC processor, GSM-GPSR Technology and data logger with cell phone. The novelty of this system is fully user controlled so that he can operate and trace path as per his necessity.*

**Keywords:** GPS, GSM, Kalmet Filter, Microcontroller, Deadreckoning & Data logger.

## INTRODUCTION

Everyone want to safe and secure life which is major concern nowadays we can use RTMU which is size similar to mobile phone or less (in case of vehicle we can use in built tracking system and for banks and building it is some larger because it consist control panel). For tracing we have control room which is totally microcontroller and programming based so easily operated and automatically update and to taking action Police and team easily trace and workout. Generally this system is meant to be installed for the four wheelers but for country like India where majority of the people using two wheelers, here is the cheapest source of RTMU. Tracking Systems are commonly used by fleet operators for fleet management functions such as routing, dispatch, on-board Information and security. Other applications include monitoring driving behaviour, such as an employer of an Employee, or a parent with a teen driver.

The rest of the paper is as follow. We review related technology in section II. In section III we proposed the design of tracking system and implementation. We conclude our work, advantages of device and future scope in section IV.

---

<sup>1</sup> Department of Electronics and Communication Engineering, Mangalmay Institute of Engineering & Technology, Knowledge Park II, Greater Noida, U.P.  
E-mail: basanta.mahato@gmail.com

## RELATED TECHNOLOGY

### GPS Technology

The Global Positioning System (GPS) is the only fully functional Global Navigation System (GNSS). The GPS uses a constellation of between 24 and 32 Medium Earth Orbit satellites that transmit precise microwave signals that enable GPS receivers to determine their location, speed, direction, and time. A GPS receiver receives the signals from at least three satellites to calculate distance and uses a triangulation technique to compute its two dimension (latitude and longitude) position or at least four satellites to compute its three dimension (latitude, longitude and altitude) position.

Therefore GPS is a key technology for giving device its position. GPS was developed by the United States Department of Defense. Its official name is NAVSTAR-GPS. It is originally used in military services but later allowed the system available free for civilian use as a common good. Since then, GPS has become a widely used aid to navigation worldwide, and a useful tool for map-making, land surveying, commerce, and scientific uses. In This device we use a GPS receiver of HOLUX GR-213 series.



Figure 1: GPS

GPS parameters and specifications are given below.

- *Builds on SiRFstarIII chipset with embedded ARM7TDMI CPU available.*
- *20 parallel satellite tracking.*
- *Support NMEA 0183 v2.2 data protocol.*
- *Built-in hardware Tracking Loop Processor WAAS/EGNOS Demodulator.*
- *Built-in repeatable and rechargeable Lithium-ion battery for Time-to-first-Fix(TTFF).*
- *For Car navigation, marine Navigation, Fleet Management, AVL and Location Based.*



Figure 2: GSM SIM900D

## **GSM TECHNOLOGY**

A GSM modem is a specialized type of modem which accepts a SIM card, and operates over a subscription to a mobile operator, just like a mobile phone. GSM (Global system for mobile) uses a process called circuit switching.

This method of communication allows a path to be established between two devices. Once the two devices are connected, a constant stream of digital data is relayed. GSM networks consist of three major systems the Switching System (SS), The Base Station (BSS) and the Mobile station (MS).

### **The Switching System**

The Switching system is very operative system in which many crucial operations are conducted, SS systems holds five databases within it which performs different functions. If we talk about major tasks of SS system it performs call processing and subscriber related functions. These databases from SS systems are HLR, MSC, VLR, AUC and EIR. The MSC in cooperation with Home Location register (HLR) and Visitor location register (VLR), take care of mobile calls and routing of phone calls. Authentication centre (AUC) is a small unit which handles the security end of the system and Equipment identity register (EIR) is another important database which holds crucial information regarding mobile equipments.

### **Base Station System (BSS):**

The base station system has a very important role in mobile communication. BSS are basically outdoor units which consist of iron rods and are usually of high length. BSS are responsible for connecting subscribers (MS) to mobile networks. All the communication is made in radio transmission. The Base station System is further divided into two systems. These two systems, they are BTS and BSC. BTS (Base Transceiver station) handles communication using radio transmission with mobile station and BSC (Base station controller) creates a physical link between subscriber (MS) and BTS, then manages and controls functions of it.

### **Mobile Station (Subscriber):**

MS consists of a mobile unit and a smart card which is also referred to as a subscriber Identity Module (SIM) card. This card is fitted with the GSM Modem and gives the user more personal mobility. The equipment itself is identified by a unique number known as the International Mobile Equipment Identity (IMEI).

The GSM modem used in this device is SIM 900D. The parameters and specifications of our GSM modem are given below.

- High Quality Product (Not hobby grade)
- Quad-Band GSM/GPRS
- 850/ 900/ 1800/ 1900 MHz
- Built in RS232 Level Converter

- (MAX3232)
- Configurable baud rate
- SMA connector with GSM L Type
- Antenna.
- Built in SIM Card holder.
- Built in Network Status LED
- Inbuilt Powerful TCP/IP protocol stack
- for internet data transfer over GPRS.
- Audio interface Connector
- Normal operation temperature: -20 °C to
- +55 °C
- Input Voltage: 5V-12V DC

## ARDUINO BOARD

The Arduino Uno is a microcontroller board based on the ATmega328. It has 14 digital input/output pins (of which 6 can be used as PWM outputs), 6 analog inputs, a 16 MHz crystal oscillator, a USB connection, a power jack, an ICSP header, and a reset button. It contains everything needed to support the microcontroller; simply connect it to a computer with a USB cable or power it with an AC-to-DC adapter or battery to get started. The Uno differs from all preceding boards in that it does not use the FTDI USB-to-serial driver chip. Instead, it features the Atmega8U2 programmed as a USB-to-serial converter.

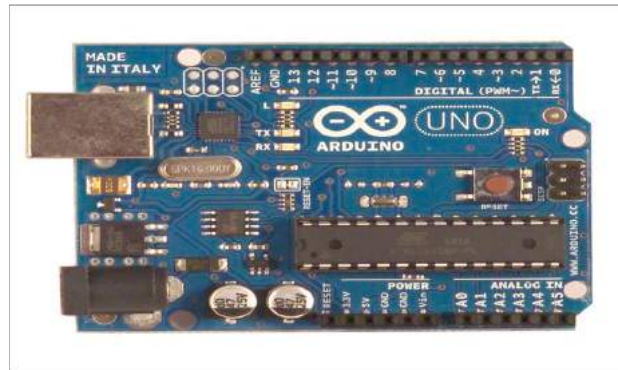

**Figure 3:** Microcontroller Board

**Table 1:** Microcontroller board specification

<i>Microcontroller</i>	<i>At mega328</i>
Operating Voltage	5V
Input Voltage (recommended)	7-12V
Input Voltage (limits)	6-20V
Digital I/O Pins	14 (of which 6 provide PWM output)
Analog Input	Pins 6



<i>Microcontroller</i>	<i>At mega328</i>
DC Current per I/O Pin	40 mA
DC Current for 3.3V Pin	50 mA
Flash Memory	32 KB of which 0.5 KB used by boot loader
SRAM	2 KB
EEPROM	1 KB
Clock Speed	16 MHz

### **Kalman Filter**

The Kalman filter is a set of mathematical equations that provides an efficient computational (recursive) means to estimate the state of a process, in a way that minimizes the mean of the squared error. The filter is very powerful in several aspects: it supports estimations of past, present, and even future states, and it can do so even. When the precise nature of the modeled system is unknown.

### **Dead Reckoning**

In navigation, dead reckoning is the process of calculating one's current position by using a previously determined position, or fix, and advancing that position based upon known or estimated speeds over elapsed time, and course.

Dead reckoning is subject to cumulative errors. Advances in navigational aids which give accurate information on position, in particular satellite navigation using the Global Positioning System, have made simple dead reckoning by humans obsolete for most purposes. However, inertial navigation systems, which provide very accurate directional information, use dead reckoning and are very widely applied.

By analogy with their navigational use, the words dead reckoning are also used to mean the process of estimating the value of any variable quantity by using an earlier value and adding whatever changes have occurred in the meantime. Often, this usage implies that the changes are not known accurately. The earlier value and the changes may be measured or calculated quantities.

### **Data Logger**

By interfacing of SD card with microcontroller for the data transfer in raw format as well as in FAT32 format. It started with raw data transfer, sending some data to any block of the microSD, reading a block of it, reading and writing multiple blocks, erasing multiple blocks. We used RS232 for viewing the data read by microcontroller from SD card. The microcontroller sends the data to HyperTerminal. Similarly, to write data to card, the data was fed thru HyperTerminal, by typing some text.

Once raw data transfer achieved, I formatted the card with windowsXP (FAT32) and loaded it with some text files, directories and other files (all stored in root directory of the card). After that I wrote the FAT32 routines to read files, get file list (using HyperTerminal again), finding the total/free memory of card. All this data is sent to HyperTerminal by the microcontroller.

## **DEGIN AND WORKING**

In this paper it is proposal to design an embedded system which is used for tracking and monitoring of any movable or non-movable thing and person by using GPS and GSM. In this device ATMEGA-128 microcontroller is used for interfacing to various hardware peripheral.

In RTMU we used different sensor for different application which is interference with microcontroller as per application.

First of all, sensor give interrupt to microcontroller as per user instruction and in case of two way communication the instruction is give to microcontroller through receiver or through DTMF circuit. After that the microcontroller flow the command as per user requirement and send GPS for location of object then that data from GPS is sends to the user through GSM module. For doing so an ATMEGA-128 microcontroller is interfaced serially to a GSM Modem and GPS Receiver. A GSM modem is used to send the position (Latitude and Longitude) of the vehicle from a remote place. The GPS modem will continuously give the data i.e. the latitude and longitude indicating the position of the object. The GPS modem gives many parameters as the output, but only the NMEA data coming out and sent to the mobile at the other end from where the position of the vehicle is demanded. When the request by user is sent to the number at the modem, the system automatically sends a return reply to that mobile indicating the position of the vehicle in terms of latitude and longitude.

Apart from this we can add KALMAN FILTER and DEADRECOKING but by using this cost of RTMU is increased so that we can minimized the component of GPS and GSM as per used.

For data storing on controller side we can use DATA LOGGER v3.2 so that we can store maximum data.

The code is written in the internal memory of Microcontroller i.e. ROM. With help of instruction set it processes the instructions and it acts as interface between GSM and GPS with help of serial communication of ATMEGA-128. GPS always transmits the data and GSM transmits and receive the data. GPS pin TX is connected to microcontroller and GSM pins TX and RX are connected to microcontroller serial ports. Microcontroller communicates with the help of serial communication. First it takes the data from the GPS receiver and then sends the information to the owner in the form of SMS with help of GSM modem. GPS receiver works on 9600 baud rate is used to receive the data from space Segment (from Satellites), the GPS values of different Satellites are sent to microcontroller ATMEGA-128, where these are processed and forwarded to GSM.

At the time of processing GPS receives only \$GPRMC values only. From these values microcontroller takes only latitude and longitude values excluding time, altitude, name of the satellite, authentication etc. E.g. LAT: 1728:2470 LOG: 7843.3089 GSM modem with a baud rate 57600.GSM is a Global system for mobile communication in this device it acts as a SMS Receiver and SMS sender. The power is supplied to components like GSM, GPS and

Micro Control circuitry using a 12V/3.2A battery .GSM requires 12V, GPS and microcontroller requires 5V with the help of regulators we regulate the power between three components.

## CONCLUSION

By using RTMU we can make our surround safe and secure.

Now we can make this more applicable and cheaper so that this device is in range of all users because safety is more matter. And for this we don't want that any one will not use this device due to money matter.

RTMU is also used for this purpose like in below given case.

- Track Suspected terrorists
- Convenience
- Parents tracking children
- Police used to track a suspected criminal or terrorist

There are many advantage of RTMU rather than disadvantage and we also work on to minimize the disadvantage and cost.

## ACKNOWLEDGEMENT

The authors thank to Mangalmay Institute of Engineering & Technology, MIET, Greater Noida, for the technical support of the test of the proposed system.

The authors would like to thank Prof. Harish Bhatia for his support for the success of this work.

The present work is a part of B.Tech. project carried out at Electronics and Communication Department, MIET.

## REFERENCES

- [1] A. Mcnamee, Faculty of Informatics - Honours Theses, *Ethical Issues arising from the Real Time Tracking and Monitoring of People Using GPS-based Location Services*, University of Wollongong Thesis Collections 2005.
- [2] Qiang Ji, Zhiwei Zhu, Peilin Lan, *Real Time Non-intrusive Monitoring and Prediction of Driver Fatigue*, Computer Vision and Image Understanding 98 (2005), pp124–154
- [3] Wang, Y. J., X.; Lee, H.K.; & Li, G.Y., (2003). "An indoors wireless positioning system based on WLAN infrastructure." 6th Int. Symp. on Satellite Navigation Technology including Mobile Positioning & Location Services.
- [4] Wertheim, Margaret. (July, 2002) "Someone to Watch Over Me" *The Age* [Online] Available URL:<http://www.theage.com.au/articles/2002/07/06/1025667073515.html?oneclick=true>
- [5] Whereify Wireless. (2001) Whereify Wireless [Online] Available URL:[http://www.whereifywireless.com/corp\\_home.htm](http://www.whereifywireless.com/corp_home.htm)
- [6] WonNamgoong & Meng, T. (2000). "GPS Receiver Design for Portable Applications." *Acoustics, Speech and Signal Processing* 6: 3706 - 3709.
- [7] Yeebo, Yepoka. (Sept. 1, 2005) "Spyed Kids", Newsweek [Online] Available URL: <http://www.msnbc.msn.com/id/9135838/site/newsweek>.

- [8] Yin, R. (1994). *Introduction: Case Study Research: Design and Methods*. London, Sage Publications. 5: 1-17.
- [9] G. Eason, B. Noble, and I.N. Sneddon, "On certain integrals of Lipschitz-Hankel type involving products of Bessel functions," *Phil. Trans. Roy. Soc. London*, vol. A247, pp. 529-551, April 1955. (*references*)
- [10] J. Clerk Maxwell, *A Treatise on Electricity and Magnetism*, 3rd ed., vol. 2. Oxford: Clarendon, 1892, pp.68-73.
- [11] I.S. Jacobs and C.P. Bean, "Fine particles, thin films and exchange anisotropy," in *Magnetism*, vol. III, G.T. Rado and H. Suhl, Eds. New York: Academic, 1963, pp. 271-350.
- [12] K. Elissa, "Title of paper if known," unpublished.
- [13] R. Nicole, "Title of paper with only first word capitalized," *J. Name Stand. Abbrev.*, in press.
- [14] Y. Yorozu, M. Hirano, K. Oka, and Y. Tagawa, "Electron spectroscopy studies on magneto-optical media and plastic substrate interface," *IEEE Transl. J. Magn. Japan*, vol. 2, pp. 740-741, August 1987 [Digests 9th Annual Conf. Magnetism Japan, p. 301, 1982].
- [15] M. Young, *The Technical Writer's Handbook*. Mill Valley, CA: University Science, 1989.

# Study of Bromide Ion Sensitive Indicator Electrode

DEVENDRA SINGH<sup>1</sup> AND ASHOK KUMAR<sup>2</sup>

## Abstract

*The preparation methods for bromide ion sensitive indicator electrodes have been described. Various electrode characteristics have been evaluated. Data has been analyzed statistically.*

**Keywords:** *Bromide Electrode, Electrode Potential, Indicator Electrode, Anion Sensitive Electrode.*

## INTRODUCTION

A number of review papers <sup>(1-6)</sup> have appeared in various journals to highlight utility of ion selective indicator electrodes for analytical work. Interest of research scholars is growing in anion sensitive specially halide ion , electrodes <sup>(7-14)</sup>. In the present paper three simple methods have been described to construct the electrode and various working parameters for the electrode have been determined.

## EXPERIMENTAL

Methods of Preparation of Electrodes

### COATED WIRE METHOD

A platinum wire ( 2 cm. long and of 0.25 mm diameter ) was fused in a Pyrex tubing as shown in Fig. 1s. It was then cleaned with chromic acid and washed with distilled water. Then it was dried in an electric oven. Silver was deposited on platinum wire using K Ag (CN)<sub>2</sub> bath at room temperature .The current and voltage were so regulated that about 0.2 gm. Of silver was deposited in about 30 minutes. It was then washed with conductivity water .This is then kept immersed in pure aqueous hydrogen bromide solution (1 %) for sufficient time so as to get a uniform coating of silver bromide on it. The electrode was again washed in conductivity water and kept immersed in it for 24 hours to attain equilibrium voltage. To ensure reproducibility over a long period of time, the electrode was maintained in conductivity water. The electrode is shown in fig 1.c

<sup>1</sup> Department of Chemistry, B. S. A. College, Mathura (U.P.)

<sup>2</sup> Department of Chemistry , G. L. A. University, Mathura (U.P.)

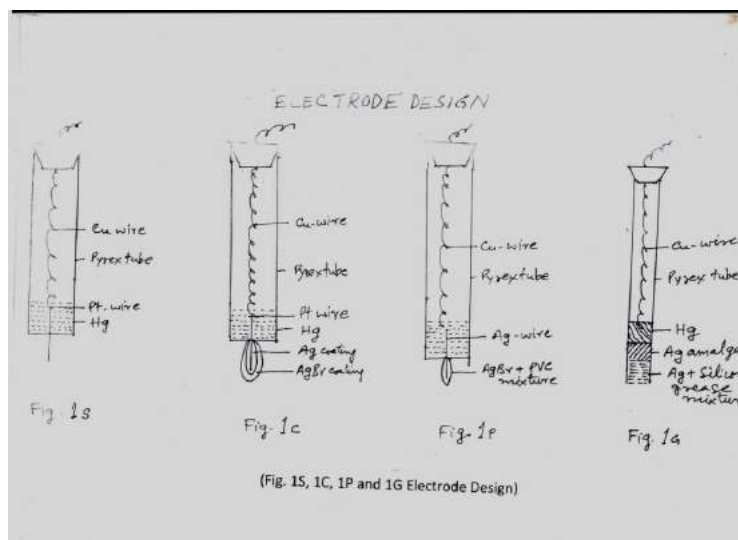

### PVC METHOD

A silver wire of length 2 cm and of diameter 0.2 mm was fused in Pyrex tubing as described above. It was immersed in a solution prepared by dissolving 90% silver bromide precipitate and 10% PVC in minimum possible volume of tetra hydrofuran. The solvent was evaporated using a water bath and the electrode was left to dry over night. It was then kept immersed in 0.0001M potassium bromide solution for 30 minutes for conditioning. The electrode was washed and kept immersed in conductivity water for 24 Hours. The electrode is now ready for use. To ensure reproducibility over a long period of time, the electrode is maintained in conductivity water after use. The electrode is shown in fig. 1P

### SILICONE GREASE METHOD

The freshly precipitated silver bromide was mixed with minimum quantity of non – reacting silicone grease (BDH England) thoroughly by, using a glass spatula and a glass plate. This cohesive mixture was then sucked into a glass tube of internal bore of 2mm. the glass assembly was then kept immersed in 0.001M potassium bromide solution for few minutes and finally in conductivity water for 24 hours. The electrode is now ready for use. To ensure reproducibility over a long period a time, the electrode was maintained in conductivity water after use. The electrode is shown in fig 1G

### STATISTICAL CALCULATIONS :-

Standard deviation, sampling variation and chi-square has been calculated as described (15-17).

$$\text{Standard deviation} = \pm \sqrt{\frac{\sum_{i=1}^{i=n} (X_i - \bar{X})^2}{n-1}}$$

Where  $\bar{X}$  is average value,  $n$  is total number of observations and  $X_i$  is individual observation.

$$\text{Sampling variance} = \frac{1}{n-2} \left[ \sum d_i^2 - \frac{\sum (d_i)^2}{n} \right]$$

Where  $d_i$  is difference between observed and theoretical values and  $n$  the total number of observations.

$$\chi^2 (\text{Chi-square}) = \sum \frac{(O-E)^2}{E}$$

Where 'O' is the observed value and 'E' is expected value. The hypothesis is accepted if chi-square calculated from observed values is less than the tabular chi-square for  $(n-1)$  degree of freedom where  $n$  is the total number of observations. Toshniwal PL52 portable potentiometer was used for emf measurements using bromide electrode coupled with saturated calomel electrode. For better accuracy external moving coil galvanometer was used. A constant temperature bath was used for maintaining fixed temperatures of solution.

## RESULTS AND DISCUSSION

The silver-silver bromide indicator electrode essentially consists of metallic silver, silver bromide salts and bromide ion.



Silver first goes into solution liberation electrons as.

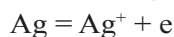

But since the solution is saturated with silver bromide, the silver ions will set the requirements of the solubility principle for this salt hence the metal ion will have to react with bromide ion to precipitate silver bromide in order to re-establish the solubility equilibrium.

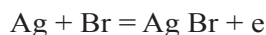

So that the net reaction is (for the sake of convenience this equation is written in the reverse manner)

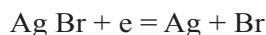

Experiments were conducted to determine reproducibility of the electrode potential for silver – silver bromide electrode at 25°C. The data have been recorded in table 1 and have been used to calculate standard deviation which is a measure of reproducibility of electrode potential.

Standard deviation value for electrode potential of electrodes prepared by PVC method, silicone grease method and coated wire method came out to be  $\pm 0.7$  mV,  $\pm 0.7$  mV and  $\pm 0.6$  mV respectively.

**Table-1.** Reproducibility behavior of electrodes at 25 °C :-

Electrode Number	Silver – silver bromide electrode potential (mV) with bromide ion concentration.					
	PVC Method		Silicone Grease Method		Coated Wire Method	
	0.57 X 10 <sup>-3</sup> M	0.57 X 10 <sup>-2</sup> M	0.57 X 10 <sup>-3</sup> M	0.57 X 10 <sup>-2</sup> M	0.57 X 10 <sup>-3</sup> M	0.57 X 10 <sup>-2</sup> M
1	-432	-503	-437	-501	-437	-501
2	-437	-501	-439	-504	-437	-501
3	-432	-509	-434	-503	-438	-501
4	-440	-508	-436	-499	-437	-501
5	-442	-501	-437	-498	-437	-502
6	-436	-499	-432	-500	-436	-502
7	-436	-497	-437	-497	-436	-500
8	-441	-500	-439	-506	-437	-501
9	-445	-499	-436	-507	-438	-501
10	-438	-504	-431	-507	-438	-501

Response time behavior of electrode prepared by the above 3 methods towards time (the time was reckoned from the moment, the electrode was immersed in bromide ion solution) has been studied. Data are recorded in table 2. As expected potential increases initially and then attaining a limiting value within a reasonable interval of time. Thereafter potential remained steady for more than 20 minutes. Thus taking readings and checking them can be done comfortably.

**Table-2.** Response behavior of electrodes at 25 °C :-

Time in Minutes	Silver – silver bromide electrode potential (mV) with bromide ion concentration.					
	PVC Method		Silicone Grease Method		Coated Wire Method	
	0.57 X 10 <sup>-3</sup> M	0.57 X 10 <sup>-2</sup> M	0.57 X 10 <sup>-3</sup> M	0.57 X 10 <sup>-2</sup> M	0.57 X 10 <sup>-3</sup> M	0.57 X 10 <sup>-2</sup> M
0.5	-455	-519	-459	-523	-440	-506
1.0	-452	-516	-455	-521	-438	-506
2.0	-449	-506	-445	-510	-437	-504
3.0	-439	-505	-440	-504	-437	-501
4.0	-437	-503	-437	-502	-437	-501
5.0	-437	-503	-436	-502	-437	-501
10.0	-437	-503	-436	-502	-437	-501
30.0	-437	-503	-436	-502	-437	-501
45.0	-437	-503	-436	-502	-437	-501
60.0	-437	-503	-436	-502	-437	-501



Durability of electrodes kept in conductivity water after use was also studied at regular interval of time. The data have been recorded in Table-3 which indicates that electrodes prepared by coated wire method were found to be most durable ( up to 25 months) while electrodes prepared by silicone grease method were were least durable (up to 10 months only).

**Table-3.** Durability behavior of electrodes at 25 °C :-

Time in Months	Silver – silver bromide electrode potential (mV) with bromide ion concentration.					
	PVC Method		Silicone Grease Method		Coated Wire Method	
	0.57 X 10 -3 M	0.57 X 10 -2M	0.57 X 10 -3 M	0.57 X 10 -2 M	0.57 X 10 -3 M	0.57 X 10 -2 M
0	-437	-503	-436	-502	-437	-501
5	-437	-500	-436	-503	-438	-501
10	-438	-504	-436	-501	-437	-500
15	-436	-502	-	-	-437	-500
20	-437	-502	-	-	-436	-501
25	-	-	-	-	-437	-501
30	-	-	-	-	-	-

The standard deviation , response time and durability for bromide indicator electrode have been summarized in tabular form as under

S.No.	Preparation Method	Standard Deviation	Response Time (Minutes)	Durability (Months)
1	PVC	±0.7mV	4	20
2	Silicone Grease	±0.7mV	5	10
3	Coated Wire	±0.6mV	3	25

As evident from the above table, coated wire type electrodes appear to give more precise results (least value of S.D.)Quicker in response and most durable. Hence, various other parameters of electrode potential have been studied only with respect to coated wire type silver-silver bromide electrode.

Graph of electrode potential in aqueous medium against logarithm bromide ion concentration is linear. The empirical equation of the straight line in aqueous medium is (Fig. 2, line eq)

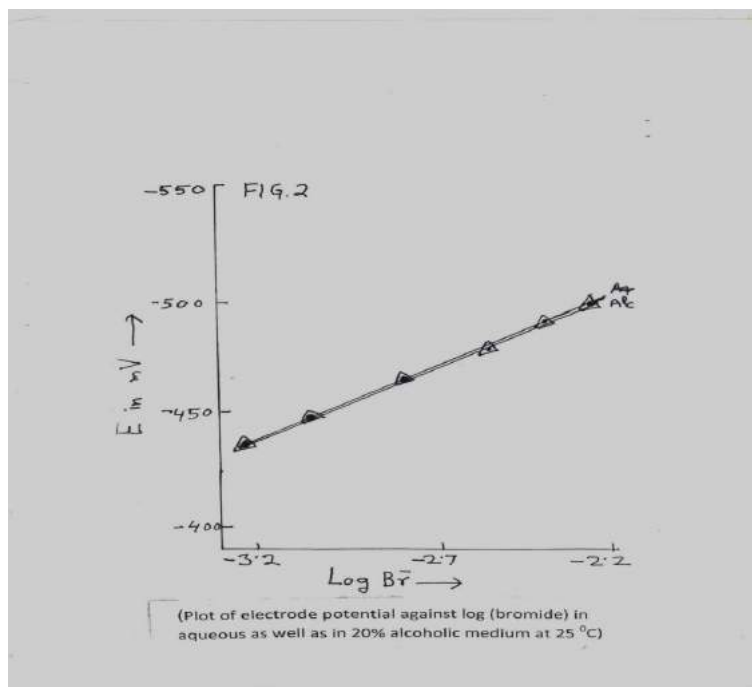

$$E = -0.647 - 0.065 \log (\text{bromide})$$

Statistical examination by “chi-square test “indicates that the difference between observed value of electrode potential and values predicted from the above equation is insignificant at 0.95 probability level (at this level both type 1 and type 2 errors are minimum). The experiments were repeated several times to check the validity of this equation with unknown bromide samples and it is observed that the average error is of the order of 0.5 %. “Sampling Variance “of the electrode potential has also been found to be small (0.7).

The change of medium of bromide solution from aqueous to 20% alcoholic did not alter the nature of empirical equation which is found to be almost the same time aqueous and alcoholic of Fig.2, line alc).  $E^0$  (mV) and slope value are tabulated below:-

S.No.	Medium	Slope Value	$E^0$ (mV)
1	Aqueous	-0.065	-647
2	20 % alcoholic	- 0.065	- 649

It is clear from the above table that bromide concentration can also be determined by the same equation in partially alcoholic medium as well. The error in unknown samples has been found to be less than 0.5 %.

To study pH determined of the electrode potential measurements have been done by making the bromide solutions buffered at pH 6.6 ,7.45, 8.0,8.6 and 9.1.The data have been plotted in line 1,2,3,4 and 5 respectively of Fig.3.

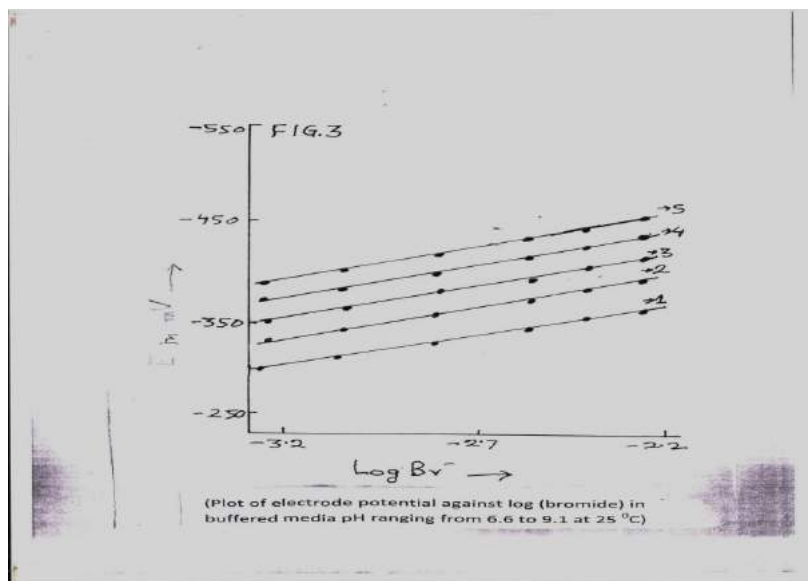

The equation of the curves has been computed and is given below:-

$$E = -0.508 - 0.065 \log (\text{bromide}), \text{pH} = 6.6$$

$$E = -0.538 - 0.065 \log (\text{bromide}), \text{pH} = 7.45$$

$$E = -0.560 - 0.065 \log (\text{bromide}), \text{pH} = 8$$

$$E = -0.579 - 0.065 \log (\text{bromide}), \text{pH} = 8.6$$

$$E = -0.599 - 0.065 \log (\text{bromide}), \text{pH} = 9.1$$

These empirical equations have been statistically examined by chi-square test at 0.95 probability level and have been found to be small. Thus these equations can be used for concentration determinations in the above buffered media fairly accurately. The error in such determination has been found less than 0.7%. The slope values and  $E^0$  (mV) values against pH of buffered media have been tabulated below :-

S.No.	pH of medium	Slope value	$E^0$ (mV)
1	6.6	-0.065	-508
2	7.45	-0.065	-538
3	8.0	-0.065	-560
4	8.6	-0.065	-579
5	9.1	-0.065	-599

As evident from the table that the slope of the lines remained unchanged with change of pH of solutions but the  $E^0$  values have been regularly changed.

Plots of potential of electrode against pH of solution keeping bromide ion concentration constant have also been found linear. Line 1,2,3,4,5 and 6 of figure 4 have been drawn for fixed concentration  $5.78 \times 10^{-4}$  M,  $9.0 \times 10^{-4}$  M,  $1.6 \times 10^{-3}$  M,  $2.86 \times 10^{-3}$  M,  $4.2 \times 10^{-3}$  M and  $5.68 \times 10^{-3}$  M respectively.

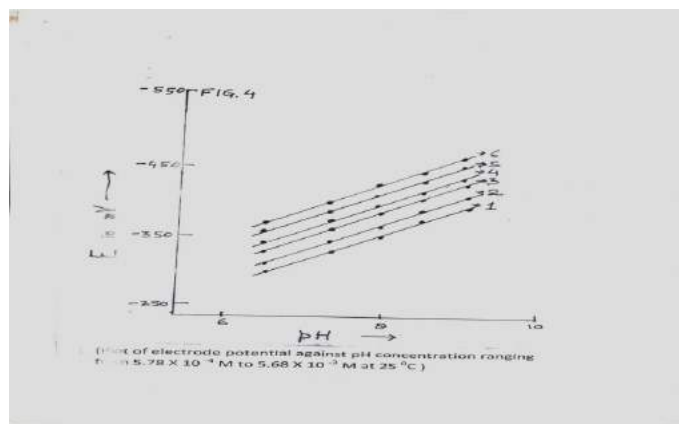

In order to incorporate pH, the Nernst equation for this system can be modified as

$$E = \pi - \frac{RT}{nF} \ln [ \text{Br}^- ]^\alpha [ \text{H}^+ ]^\beta$$

Where  $\alpha$  and  $\beta$  are arbitrary constants whose values have been determined from the experiments to be 2.2 and 0.6 respectively.

The constant,  $\pi$ , in the proposed equation differs from standard electrode potential  $E^0$ , which depends on the nature of the electrode. The constant,  $\pi$ , represents better value of the constant as pH of solution has also been taken into consideration.

The temperature coefficient of the electrode potential have been calculated to be  $-1.19$  mV per degree centigrade ( Fig. 5, lines 1,2 &3 are for concentration  $0.57 \times 10^{-3}$  M ,  $1.6 \times 10^{-3}$  M , and  $0.57 \times 10^{-2}$  M ).

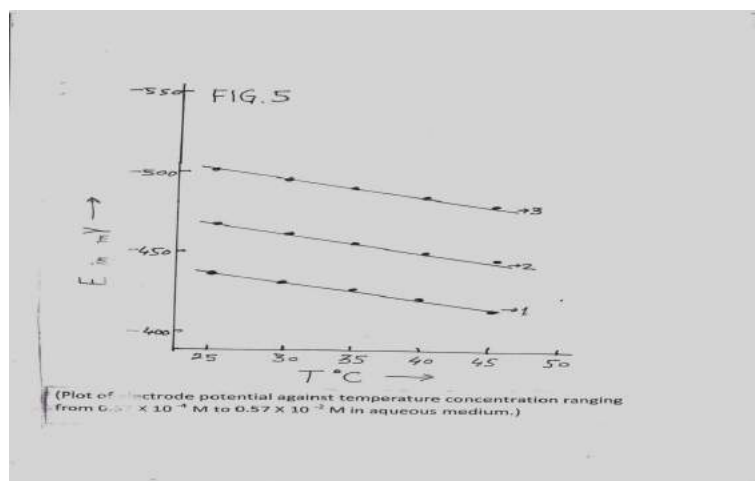

Impurities of other anion in bromide solution in small concentrations do not affect the electrode potential practically with the exception of nitrate ion and hence should be avoided. Data have been shown for carbonate, chloride, fluoride, iodide, cyanide, sulphate and nitrate in Table 4.

**Table-4.** Effect of impurity anion in bromide solution on silver-silver bromide electrode potential at 25°C :-

Impurity Salt	Bromide ion concentration X 10 <sup>-3</sup> M	Impurity concentration X 10 <sup>-6</sup> M	% Impurity of Bromide ion	Potential change (mV)
Na <sub>2</sub> CO <sub>3</sub>	1.6	1	0.062	0
		5	0.31	1
NaCl	1.6	1	0.062	0
		5	0.31	0
NaF	1.6	1	0.062	1
		5	0.31	2
NaI	1.6	1	0.062	0
		5	0.31	0
KCN	1.6	1	0.062	0
		5	0.31	0
Na <sub>2</sub> SO <sub>4</sub>	1.6	1	0.062	0
		5	0.31	0
NaNO <sub>3</sub>	1.6	1	0.062	5
		5	0.31	7

## CONCLUSION

It can be safely concluded from above discussion that silver – silver bromide electrode prepared by coated wire method is suitable for use as it is quite reproducible, attain equilibrium potential fairly, quickly and is quite stable for storage. It can measure bromide ion concentration in aqueous, alcoholic, acid/basic buffered media and as such holds a good future in analytical work.

## ACKNOWLEDGEMENTS

The authors wish to express sincere thanks to Dr. Babita Agrawal (Head, Department of Chemistry, B.S.A. College, Mathura) and Dr. Ashok Agrawal (Principal B.S.A. College, Mathura) for providing necessary facilities. We are also thankful to Prof. D. K. Das (Head Department of Chemistry GLA University, Mathura) and Dr. Prabal Pratap Singh, Dr. Vivek Sharma, Dr. Seema Jain and Dr. Basant Lal, Department of Chemistry, GLA University, Mathura for their sincere advise.

## REFERENCES

- [1] Pungor and Toth, *Analyst*, 95 (1132), 1970, 625
- [2] Pritsch, Erno, *Chimia*, 55 (10), 2001, 875
- [3] Wellford, Peter et al, *Anal. Chem.*, 73 (24) 2001, 6088

- [4] Pungor, Erno, *Sensors*, 1 (1) 2001, 1
- [5] Grygar, Thomas et al, *Call, of Czech. Chem. Comm.* 62 (2), 2002, 163
- [6] Jim, Litong, *Huaxue Chuangangi*, 21(3), 2001, 25
- [7] Pandey UK, Agrawal BL and Gurtu A k, *J. Electrochem. Soc. India*, 320, 1981
- [8] Gan X et al *Huaxue Chuangangi* 23, (2003), 29
- [9] Dai JY, Chai, Yuan R, *Analytical Letters*, 38, (2005), 389
- [10] Segui M, *Jetal Talanta*, 68, (2006), 1189
- [11] Mojtaba Shamspur, Shohrechrouhani et al, *Analytica Chimica Acta* 418 (2000) 197-203
- [12] Rechnitz G A, Kresx M. R., *Analytical Chem.* 1966, 38 (12), 1786-1788
- [13] Noszticzlus Z, Noszticzlus E and Schally Z. A., *J. Phys. Chem.* 87, (1983), 510-524
- [14] Tamer Awad Ali, Gehad G. Mohamed et al, *Int. J. Electrochem. Sci*, 10 (2015) 4820-4831
- [15] Brown G and Sallec EM, *quantitative Chemistry*, pretence hall, Inc, Engle wood Clips, NJ, Ist Ed. 1967, P 104.
- [16] Goulden CH, *Methods of statistical analysis*, John Willey & Sons, N Y, Ist Ed, 1956, P 200.
- [17] Kendall MF and Stuart A, *The advanced theory of statistics*, Charles Griffen & Company Limited London IInd Ed, 1960, P 7

# Finish Hard Turning of En31 Steel Using Minimum Quantity Lubrication: Surface Integrity Analysis

NAMIT SINGH BHADAURIA<sup>1</sup> AND GAURAV BARTARYA<sup>2</sup>

## Abstract

*During machining process, use of cutting fluid plays a significant role. It takes away the heat from the cutting zone that results in longer tool life and improved surface quality. Cutting fluid also hinders the corrosion of both the work piece and machine tool while helping in removing chips from the cutting zone, thus promoting tool cleaning. But, there are some negative effects of using cutting fluid in machining e.g. creating toxic waste that is hazardous to environment and increases machining cost. To reduce these ill effects of cutting fluids, a Minimum Quantity Lubrication (MQL) technique has been employed during machining of hard steels. As the name implies, MQL turning uses a very small amount of cutting fluid delivered precisely to the machining zone. The present work is an effort to examine and establish the use of MQL techniques during hard turning for betterment of surface finish and the reduction of white layer during finish hard turning. Generally, hard turning is performed with the absence of cutting fluid. Also, white layer is formed when machining is done with the worn out tool which should be avoided as far as possible, as it reduces fatigue strength of work piece. From literature, it is seen that use of MQL reduces the propagation of the tool wear. A number of studies have shown that compared to dry turning; MQL turning improve cutting performance in terms of increasing tool life. As generation of white layer during hard turning is largely dependent on the flank wear present on the tool. Hence use of MQL should also abate the white layer generation. To verify this concept hard turning experiments have been performed. The work piece material selected for the work is EN31 steel (hardened to 60 HRC). Ceramic inserts have been used as cutting tool. The experiments are performed by taking three parameters namely: cutting speed, feed and depth of cut. The number of experiments to be performed has been planned by the help of Box-Behnken method. The surface roughness and white layer have been analysed with and without MQL environment and the concept developed has been verified.*

**Keywords:** *Minimum Quantity Lubrication, Tool Wear, Surface Roughness, White Layer Formation, Ceramic Insert, EN31 Steel*

## INTRODUCTION

Using cutting fluids during machining process plays a significant role in reduction of temperature and lubrication to tool and work piece. This results in longer tool life and

---

<sup>1</sup> Department of Mechanical Engineering, Harcourt Butler Technical University, Kanpur  
E-mail: 12namit@gmail.com

<sup>2</sup> Department of Mechanical Engineering, Harcourt Butler Technical University, Kanpur,  
E-mail: gbartarya@yahoo.co.in

improved surface finish. On the other hand, using cutting fluids in machining has side effects to the environment, workers' health, and manufacturing cost as shown in Figure 1. In order to overcome the effect, a technique called minimal quantity lubrication (MQL) was developed to combine the advantages of both wet and dry cutting. MQL is a technique which sprays small amount of cutting fluid to the cutting zone area with the aid of compressed air. The overall performance results are better than dry and conventional wet machining in terms of increase in tool life, reduction of cutting forces, temperature and also enhance surface finish, which is beneficial environmentally and also economically. It is noted that the chip formation and chip-tool interaction become more favourable under MQL condition.

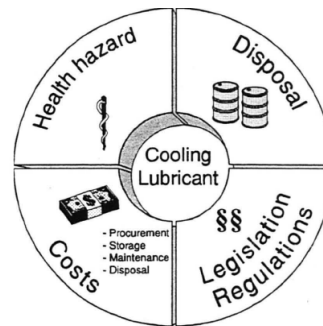

**Figure 1:** Disadvantages of Lubricant [1].

Bartarya and Choudhury [2] studied the effect of cutting parameters on cutting force and surface roughness during finish hard turning of EN31 steel. From the result, the depth of cut was found to be the most significant parameter affecting the three cutting forces followed by the feed. The response surface analysis showed that the forces first decreased and then increased with increase in cutting speed, indicating towards the thermal softening of the workpiece. Paolo C. Priarone et al. [3] performed a series of experiments on turning of titanium aluminised by using Minimum Quantity Lubrication. They compare the MQL with dry and wet condition on the basis of tool wear and surface quality. Coated carbide tools were used as a cutting tool. It was observed that the minimum quantity lubrication produced the most sustainable cutting conditions. M. Ibrahim [4] studied wear development and cutting forces using CBN cutting tool in Hard Part turning of different hardened steels. It was observed that there was no difference in tool performance for turning of case and induction hardened steel, while the tool performance was relatively low in turning of through hardened steel. The fastest wear development appeared in turning of through hardened steel. Bartarya and Choudhury [5] discussed the state of art in hard turning especially surface integrity issues. It was concluded that the white layer formation was due to phase transformation to martensite. It was also observed that the use of coolant might help in decreasing the white layer thickness and residual stresses due to lower flank wear growth rate. A. Attanasio et al. [6] used minimum quantity lubrication during turning and studied its effect on tool wear. The results were obtained from the turning tests and SEM analysis of tools, using MQL on the rake and flank of the tool. Experimental results were compared between MQL and dry cutting conditions. The results obtained showed



that when MQL was applied to the tool rake, tool life was generally no different from dry conditions, but when MQL was applied to the tool flank, tool life was found increased.

## EXPERIMENTAL DETAILS

In accordance to the literature, EN31 steel was selected for experimental work. Each workpiece was 150 mm long. Workpiece diameter was 30 mm and 35 mm. Ceramics insert was selected for machining of hardened EN31 steel. Number of Experiments to be performed was decided by the help of Box-Behnken method. The ranges of velocity, feed and depth of cut were selected based on lathe machine capability, tool manufacturer criteria and surface finish parameters according to the literature. The following table 2 shows cutting parameters at which experiments will be performed.

**Table 2.1:** Cutting Parameters

<i>Parameters</i>	<i>Low Level</i>	<i>Medium Level</i>	<i>High Level</i>
Velocity (m/min)	95	140	185
Feed (mm/rev)	0.08	0.13	0.18
Depth of Cut (mm)	0.1	0.15	0.2

## WORKING CONDITIONS AND SET-UP

The machining of hardened steel was performed in lathe machine. EN31 hardened steel was turned under two conditions which were dry cutting and MQL cutting. In dry cutting, material was turned without use of any cutting fluid. Whereas, in MQL cutting, material was turned with the use of cutting fluid. The ratio of oil to water was kept 1:20. After the complete set-up in lathe machine, hardened steel was machined using MQL. The flow rate of cutting fluid was kept constant throughout the experiment. Cutting fluid and compressed air was mixed inside a nozzle which produce atomized solution. This atomized solution was sprayed precisely between tool and workpiece during turning. Figure 4.2 shows the spraying of mist solution during turning.

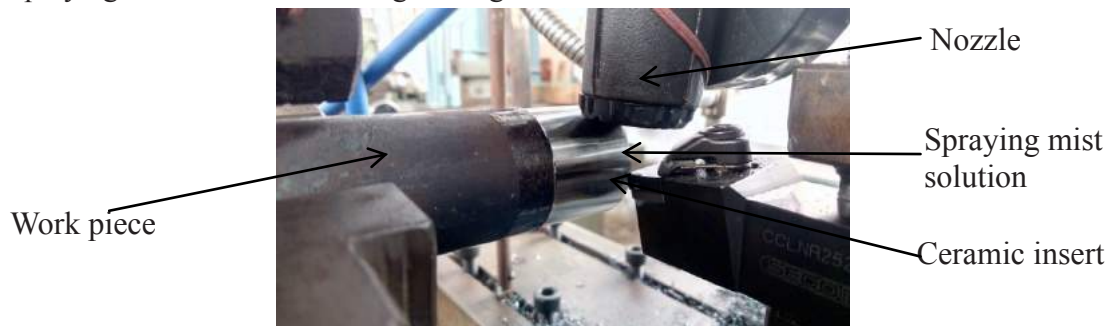

**Figure 2:** Nozzle spraying mist solution at the cutting tool insert.

The material was also dry hard turned to compare the result. The cutting conditions were kept same as when machining is performed with MQL.

## **SURFACE INTEGRITY TEST**

After the turning of hardened EN31 steel with and without MQL, various experimental tests were made to check the integrity of machined surface. These tests are:

### **SURFACE ROUGHNESS**

Roughness was measured for each workpiece at three different points. Then average was calculated of three points and recorded as  $R_a$  value.

### **TOOL WEAR MEASUREMENT**

Wear that occurs at flank surface is called flank wear [as shown in figure 3. A USB connected Dino-lite optical microscope was used to measure the tool wear.

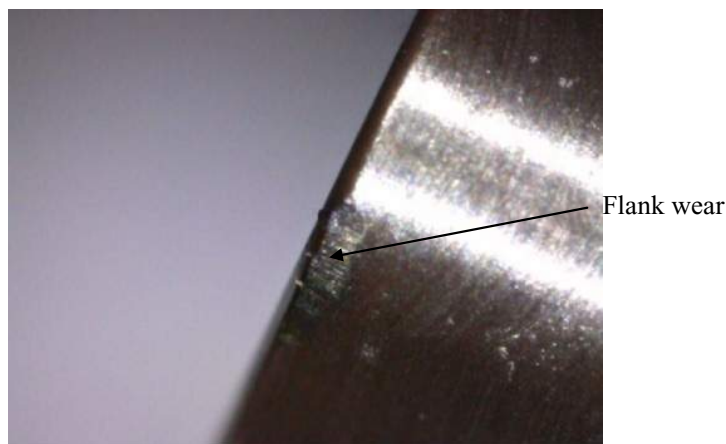

**Figure 3:** Flank wear

### **SCANNING ELECTRON MICROSCOPY**

During hard turning, a white layer was formed over the turned surface. The scanning electron microscope (SEM) was used for observation of specimen surfaces. For SEM analysis, a sample of size 10mm x 10mm was prepared. This white layer can be visually seen in SEM images.

## **RESULT AND DISCUSSION**

The results have been analysed to find the effect of the cutting parameters i.e. speed, feed and depth of cut on the surface roughness and flank wear have been analysed for hard turning with and without MQL. Also the effect of MQL on white layer generation has been analysed.

### **Surface Roughness**

To determine the surface finish, the roughness was measured for both cutting conditions i.e. with and without MQL.

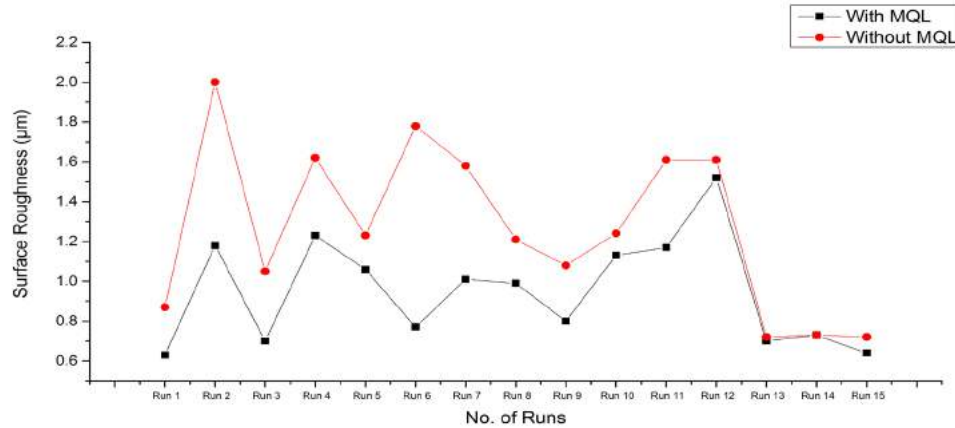
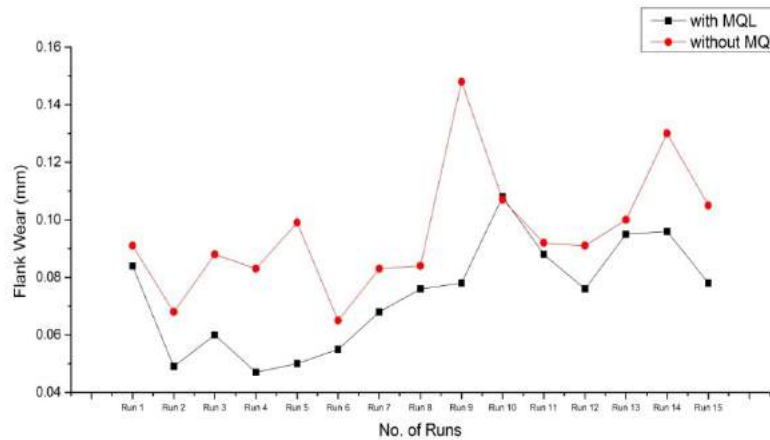

**Figure 4:** Comparison of surface roughness between MQL and without MQL.

From the figure 4, it was observed that the surface roughness produce during MQL turning was less than that when it was performed without MQL.

### Tool Wear

Figure 5 is presented for compare flank wear between MQL and without MQL.

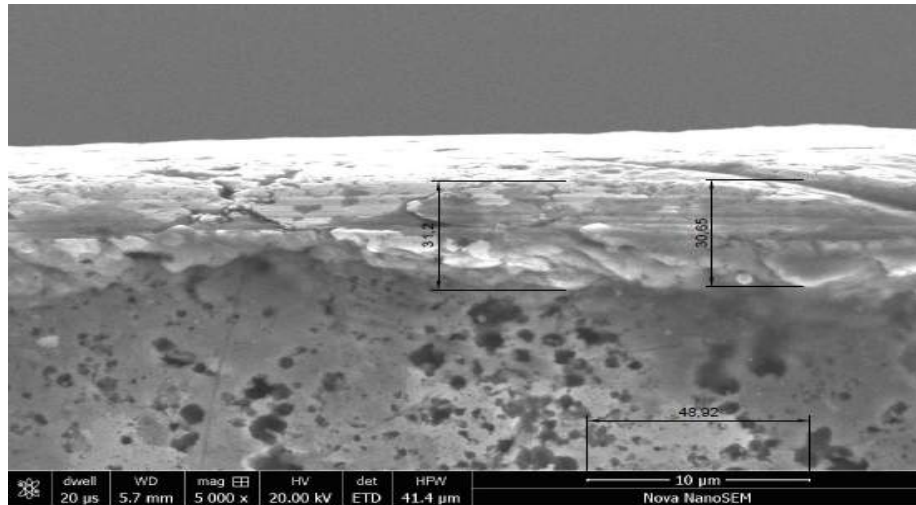

**Figure 5:** Comparison of flank wear between MQL and without MQL.

From the figure, it can be observed that flank wear generated during the machining with MQL is lesser than then the machining without MQL for same cutting conditions.

### WHITE LAYER FORMATION

White layer formed over work piece was observed in SEM. Figures 6 shows the white layer formation over workpiece.



**Figure 6:** White layer formation

It was observed that white layer was formed for both cutting conditions when machining was performed at high cutting speed.

## CONCLUSIONS

Based on the results and analysis of the machinability study of finish hard turning of EN 31 steel with uncoated ceramic inserts with and without Minimum Quantity Lubrication, the following conclusions could be made.

Turning of hardened steel with MQL provides better surface roughness when compared with turning without MQL.

Tool wear reduces when turning of hardened steel with MQL than turning without MQL.

White layer forms for both MQL and without MQL conditions.

## REFERENCES

- [1] Heisel, U. and LulZ, M., 1993. *Investigation of cooling and lubricating liquids*, *Production Engineering*, Volume III, pp. 23 – 26.
- [2] GauravBartarya and S. K. Choudhury, 2012. *Effect of cutting parameters on cutting force and surface roughness during finish hard turning AISI52100 grade steel*, *Procedia CIRP*, Vol. 1, pp.651 – 656.
- [3] Paolo C. Priarone, MatteoRobiglio, Luca Settineri and Vincenzo Tebaldo, 2014. *Milling and turning of titanium aluminides by using minimum quantity lubrication*, *Procedia CIRP*, Vol. 24, pp.62 – 67.
- [4] M. Ibrahim. Sadik, 2012. *Wear development and cutting forces on CBN cutting tool in Hard Part turning of different hardened steels*, *Procedia CIRP*, Vol. 1, pp.232 – 237.

- [5] GauravBartarya and S.K.Choudhury, 2012.*State of the art in hard turning*, International Journal of Machine Tools and Manufacture, Vol.53, Issue 1, pp.1-14.
- [6] A. Attanasio, M. Gelfi, C. Giardini and C. Remino, 2006.*Minimal quantity lubrication in turning: Effect on tool wear*, Wear, Vol. 260, pp. 333–338.
- [7] A.S. Varadarajan, P.K. Philip and B. Ramamoorthy, 2002. *Investigations on hard turning with minimal cutting fluid application (HTMF) and its comparison with dry and wet turning*, International Journal of Machine Tools Manufacture, Vol 42, Issue 2, pp.193-200.
- [8] NouredineBoubekri and VasimShaikh, 2015.*Minimum Quantity Lubrication (MQL) in Machining: Benefits and Drawbacks*, Journal of Industrial and Intelligent Information, Vol. 3, issue 3, pp.205-209.

# Experimental and Theoretical (ab initio/ HF) Analysis of Vibrational Spectra, Thermodynamic Functions and Non-linear Optical Properties of 2,6-Dimethyl-4-nitrophenol

SARVENDRA KUMAR<sup>1</sup>, SURBHI<sup>2</sup> AND M.K. YADAV<sup>3</sup>

## Abstract

*The FT-IR and FT-Raman spectra of 2,6-Dimethyl-4-nitrophenol has been recorded in the range of 4000-100cm<sup>-1</sup>. The fundamental mode of vibrational frequencies of compounds 26DM4NP is assigned. All the geometrical parameters have been calculated by using HF method with 6-311++G(d,p) basis set. Optimized geometries of the molecules have been interpreted and compared with the reported experimental values for substituted phenols. The harmonic and an harmonic vibrational wave numbers, IR intensities, Raman activities, reduced mass and force constants are calculated at the same theory level used in geometry optimization by the scaled vibrational frequencies at HF /6-311++G(d,p) seems to coincide with the experimentally observed values with good agreement. The difference between observed and scaled wave number values of most of the fundamentals is very small in HF. The molecular interactions between the substitutions [OH, CH<sub>3</sub> and NO<sub>2</sub>] are also analyzed. The thermodynamic parameters have also been calculated at the same theory level.*

**Keywords:** 2,3,4-CDMB, HF, NLO Properties.

## INTRODUCTION

Phenols are organic compounds that contain a hydroxyl group (OH) bound directly to a carbon atom in the benzene ring. Unlike normal alcohols, phenols are acidic because of the influence of the aromatic ring. Phenol derivatives are interesting molecules for theoretical studies due to their relatively small size and similarity to biological species. Phenols are widely used as synthetic organic materials and also as antioxidants in living organisms. Phenoxy radicals represent important intermediates in many biological and industrial applications.

<sup>1</sup> Amity Institute of Applied Sciences, Amity University, Noida, (U.P.)

<sup>2</sup> Amity Institute of Applied Sciences, Amity University, Noida, (U.P.)

<sup>3</sup> Department of Physics, D.N.College, Meerut (U.P.)

Phenols are made by fusing a sulphonic acid with sodium hydroxide to form the sodium salt of the phenol. The free phenol is liberated by adding sulphuric acid. It is used as anti-bacterial and anti-septic and also for the treatment of surgical instrument and bandaging materials. In recent years, phenol and substituted phenol have been the frequent subjects of experimental and theoretical work because of their significance in industry and environment.

The vibrational spectrum of phenol was extensively studied and analyzed. Various spectroscopic studies of chloro and methyl phenols have been reported in the literature (1-3). Recently, Sing and Rai have studied the infrared and the electronic absorption spectra of 4-chloro-3-methyl and 6-chloro-3-methyl phenols. A complete vibrational assignment of phenol and phenol-OD has been given (4-6). The vibrational spectra of p-cresol and its deuterated derivatives have been studied by Jakobsen(7), who gave detailed interpretations of the vibrational bands. The assignment of the vibrational frequencies for substituted phenols becomes complicated problem because of the superposition of perhaps several vibrations due to fundamentals and due to substituent's. However, a comparison of the spectra with that of the parent compound gives some definite clues about the nature of the molecular vibrations. The Raman spectra of this compound and its three deuterated derivatives in the liquid state and the infrared spectra in the liquid, vapour and solid state have been reported partially by Jacobsen (8). Davy Dova et al. (9) calculated the normal frequencies of out-of-plane vibrations and assigned some of the infrared and Raman bands Green et al. (10) proposed complete assignments of fundamental frequencies for non-deuterated p-cresol. The vibrational assignment of infrared spectrum of phenol was extensively studied by Evans (11), but there seems to be no complete analysis of vibrational spectra for those of o-, m-, and p-nitro phenols. The far infrared spectra of isomeric nitro phenol in the region 240–20  $\text{cm}^{-1}$  were investigated by Stanevich (12) in the crystalline and liquid states. The vibrational spectra of p-nitro phenol in the region 300–1600  $\text{cm}^{-1}$  were studied by Jacobsen and Brewer (13). Kishore et al. (14) recorded the infrared absorption spectra of o-, m- and p-nitro phenols in the region 200–4000  $\text{cm}^{-1}$  using KBr pellet technique. The spectra were analyzed assuming  $C_{2v}$  point group for p-nitro phenol and  $C_s$  point group for o- and m nitro phenol.

In the present work, we have studied the FT-IR and FT-Raman spectra of 26DM4NP. The comparative IR and Raman spectra of experimental and calculated for compound 26DM4NP are given in Fig. 2 and Fig. 3 respectively. The ab-initio HF calculations are performed to obtain the ground state optimized geometries and the vibrational wave numbers of the different normal modes as well as to predict the corresponding intensities for the different modes of the molecule.

## **EXPERIMENTAL DETAILS**

The spectroscopic grade 26DM4NP was purchased from Sigma Aldrich chemicals, U.S.A. and used as such for recording spectra without further purification. The FT-IR spectrum of the titled compound was recorded in Bruker IFS 66V spectrometer in the range of 4000-100 $\text{cm}^{-1}$ . The spectral resolution is  $\pm 2\text{cm}^{-1}$ . The FT-Raman spectrum of 26DM4NP was also recorded in the same instrument with FRA 106 Raman module equipped with Nd:

YAG laser source operating at  $1.064\mu\text{m}$  with 200MW power. The spectra were recorded in the range of  $4000\text{-}100\text{cm}^{-1}$  with scanning speed of  $30\text{cm}^{-1}\text{ min}^{-1}$  of spectral width  $2\text{ cm}^{-1}$ . The frequencies of all sharp bands are accurate to  $\pm 1\text{cm}^{-1}$ .

## COMPUTATIONAL DETAILS

Many studies (18-20) have shown that the HF method in combination with the 6-311++G (d, p) basis set is able to give the accurate energies, molecular structures, and infrared vibrational frequencies. The molecular structure of the 26DM4NP in the ground state is computed by performing *ab initio*-HF with 6-311++G (d, p) basis set. The optimized structural parameters are used in the vibrational frequency calculations at HF levels. The minimum energy of geometrical structure is obtained by using level 6-311++G (d, p) basis set. The calculated frequencies are scaled by 0.8919 for HF/6-311++G (d, p). HF calculations for 26DM4NP are performed using GAUSSIAN 09W program package on Pentium IV processor personal computer without any constraint on the geometry (21-22).

## RESULT AND DISCUSSION

### Molecular geometry

The molecular structure of the 26DM4NP belongs to  $C_s$  point group symmetry. The optimized molecular structure of titled molecules is obtained from GAUSSAN 09W and GAUSSVIEW programs are shown in Fig.1.

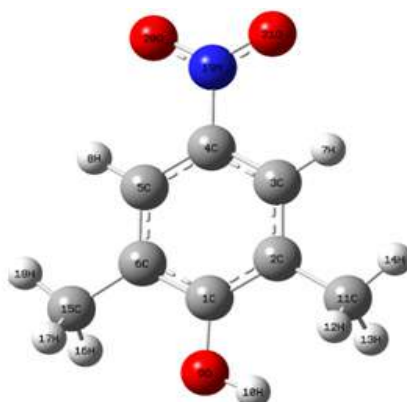

**Figure 1:** Molecular Structure of 26DM4NP

The molecules contain OH,  $\text{CH}_3$  and  $\text{NO}_2$  connected with benzene ring. The comparative optimized structural parameters such as bond lengths, bond angles for compound are presented in Table 1 and. The optimized bond lengths may be slightly larger than the experimental values, due to that the theoretical calculations belong to isolated molecules in gaseous phase and the experimental results belong to molecules in solid state. Comparing bond angles and lengths of B3LYP with those of HF, as a whole the formers are bigger than later and the B3LYP calculated values correlates well compared with the experimental data.



**Table 1.** Optimised geometrical parameters for 2,6-dimethyl-4-nitrophenol computed at HF/6-311++G(d,p) basis set

<i>BOND LENGTHS (Å)</i>	<i>HF/ 6-311++G(d,p)</i>	<i>BOND ANGLES (°)</i>	<i>HF/6-311 ++ G(d,p)</i>
C1-C2	1.41	C2-1C-C6	122.4
C1-C6	1.41	C2-C1-O9	121.6
C1-O9	1.36	C6-C1- O9	116.1
C2-C3	1.39	C1-C2-C3	118.2
C2-C11	1.51	C1-C2-C11	120.5
C3-C4	1.39	C3-C2-C11	121.3
C3-H7	1.08	C2-C3-C4	119.8
C4-C5	1.39	C2-C3-H7	120.9
C4-N19	1.47	C4-C3-H7	119.3
C5-C6	1.39	C3-C4-C5	121.7
C5-H8	1.08	C3-C4-N19	119.1
C6-C15	1.51	C5-C4-N19	119.2
9O-H10	0.96	C4-C5-C6	120.0
C11 -H12	1.10	C4-C5-H8	119.3
C11 -H13	1.10	C6-C5-H8	120.7
C11 -H14	1.09	C1-C6-C5	118.0
C15 -H16	1.09	C1-C6-C15	120.1
C15 -H17	1.09	C5-C6-C15	121.9
C15 -H18	1.09	C1- O9-H10	110.5
N19 -O20	1.23	C2-C11-H12	111.9
N19 -O21	1.23	C2-C11-H13	111.9
		C2-C11-H14	110.7
		H12-C11-H13	107.8
		H12-C11-H14	107.1
		H13-C11-H14	107.1
		C6-C15-H16	111.1
		C6-C15-H17	111.1
		C6-C15-H18	110.7
		16H-15C-17H	106.7
		H16-C15-H18	108.5
		H17-C15-H18	108.5
		C4-N19- O20	117.9
		C4-N19- O21	117.9
		O20-N19-O21	124.2

## VIBRATIONAL ASSIGNMENT

The 26DM4NP consists of 21 atoms, which belongs to  $C_s$  symmetry. Hence the number of normal modes of vibrations for 26DM4NP works to be 57. Of the normal modes of vibrations, 39 modes of vibrations are in plane and remaining 18 are out of plane for 26DM4NP. The bands that belong to the in-plane modes are represented as  $A'$  while the out-of-plane modes as  $A''$ . Thus the 57 modes of vibrations are distributed as  $Vib = 39A' + 18A''$ . All the 57 fundamental vibrations are active both in Raman scattering and in IR absorption. The harmonic-vibrational frequencies calculated for 26DM4NP at HF 6-311++G(d,p) basis set level and observed FT-IR and FT-Raman frequencies for various modes of vibrations are presented in the Tables 2. Although basis set are marginally sensitive as observed in the HF values using 6-31++1G (d,p), reduction in the computed harmonic vibrational frequencies are noted. Without affecting the basic level of calculations, it is customary to scale down the calculated harmonic frequencies in order to get an agreement with the experimental values. The scaled calculated frequencies minimize the root-mean square difference between calculated and experimental frequencies for bands with definite identifications.

**Table 2.** Observed and calculated vibrational frequencies of 2,6 Dimethyl-4-nitrophenol by HF 6-311++G(d,p) level:

S.No.	Symmetry Species $C_s$	Observed Frequencies		Calculated Frequencies HF/6-11++G(d,p)		Vibrational Assignment
		FT-IR	FT-Raman	Unscaled Values	Scaled Values	
1	$A'$	3738vw	–	4199	3742	(O-H)□
2	$A'$	3080vw	–	3388	3020	(C-H)□
3	$A'$	–	–	3387	3019	(C-H)□
4	$A'$	–	–	3259	2905	(C-H)□as
5	$A'$	–	–	3255	2901	(C-H)□as
6	$A'$	–	–	3233	2882	(C-H)□as
7	$A'$	–	2934w	3195	2847	(C-H)□as
8	$A'$	—	–	3178	2832	(C-H)□s
9	$A'$	–	–	3150	2808	(C-H)□s
10	$A'$	1593m	1596w	1830	1631	(C=C)□
11	$A'$	–	–	1778	1585	(C=C)□
12	$A'$	1508s	–	1768	1576	(N-O)□as
13	$A'$	1481m	–	1645	1467	(C-H)δ
14	$A'$	–	–	1625	1448	(C-H)δ
15	$A''$	–	–	1613	1438	(C-H)δ

S.No.	Symmetry Species Cs	Observed Frequencies		Calculated Frequencies HF/6-11++G(d,p)		Vibrational Assignment
		FT-IR	FT-Raman	Unscaled Values	Scaled Values	
16	A''	-	-	1609	1434	(C-H) $\delta$
17	A'	-	-	1598	1425	(C-C) $\square$
18	A'	-	-	1587	1414	(C-C) $\square$ +(C-H) $\delta$
19	A'	-	-	1574	1403	(C-H) $\delta$
20	A'	1381m	-	1545	1377	(C-H) $\delta$
21	A'	-	1328vs	1539	1372	(C-C) $\square$ +(O-H) $\delta$
22	A'	1287s	-	1421	1267	(N-O) $\square$
23	A'	1252s	1254w	1410	1257	(C-H) $\delta$
24	A'	-	-	1357	1210	(C-H) $\delta$ +(O-H) $\delta$
25	A'	-	-	1337	1192	(CCC) $\delta$
26	A'	1185s	1186w	1284	1144	(O-H) $\delta$
27	A'	1099s	1098w	1216	1084	(C-H) $\delta$
28	A'	-	-	1165	1039	(C-H) $\delta$
29	A'	1032s	-	1156	1031	(C-H) $\delta$
30	A''	-	-	1108	988	(C-H) $\gamma$
31	A''	-	952vw	1101	982	(C-H) $\gamma$
32	A'	945s	-	1045	931	(C-N) $\square$
33	A'	-	-	1031	919	(C-CH <sub>3</sub> ) $\delta$
34	A''	-	-	1025	913	(C-H) $\gamma$
35	A''	904s	-	1013	903	(C-H) $\gamma$
36	A'	-	811vw	909	810	(NO <sub>2</sub> ) $\delta$ +(C-OH) $\square$
37	A'	748m	735vw	824	734	(C-N) $\delta$
38	A''	732	-	797	711	(N-O) $\gamma$
39	A''	-	-	796	709	(C-O) $\gamma$
40	A'	-	-	652	581	(CCC) $\delta$
41	A'	-	533vw	601	536	(CCC) $\delta$
42	A''	-	-	583	519	(C-H) $\gamma$

S.No.	Symmetry Species Cs	Observed Frequencies		Calculated Frequencies HF/6-11++G(d,p)		Vibrational Assignment
		FT-IR	FT-Raman	Unscaled Values	Scaled Values	
43	A'	503	–	559	498	(C-CH3)□
44	A''	–	–	539	481	(CCC)γ
45	A'	–	–	468	417	(NO2)δ
46	A'	–	–	392	349	(C-N)□
47	A''	–	–	374	333	(O-H)γ
48	A''	–	–	349	311	(O-H)γ
49	A'	–	–	301	268	(C-O)δ
50	A'	–	–	293	261	(C-CH3)δ
51	A''	–	–	247	220	(C-CH3)γ
52	A'	–	–	215	192	(C-N)□
53	A''	–	–	172	153	(C-CH3)γ
54	A''	—	–	161	143	(C-CH3)γ
55	A''	–	–	151	134	(C-CH3)γ
56	A''	–	–	118	105	(CH3) t
57	A''	–	–	48	43	(NO2)t

vs- very strong; s-strong ;m-medium; w-weak; as-asymmetric; s-symmetric ; □-stretching ;δ-in plane bending; γ-out plane bending; t-twisting.

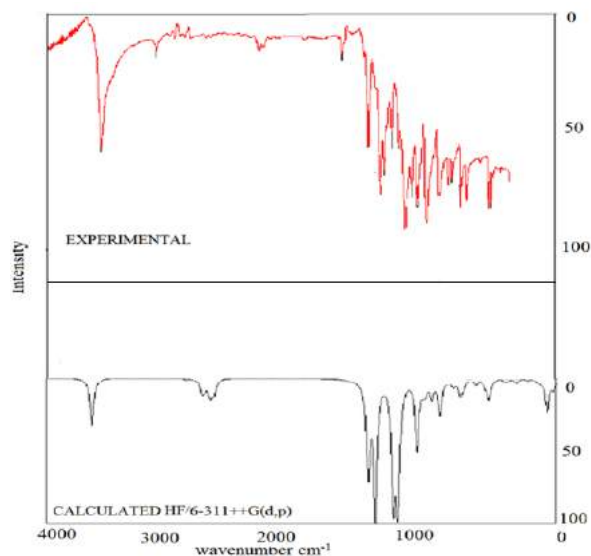
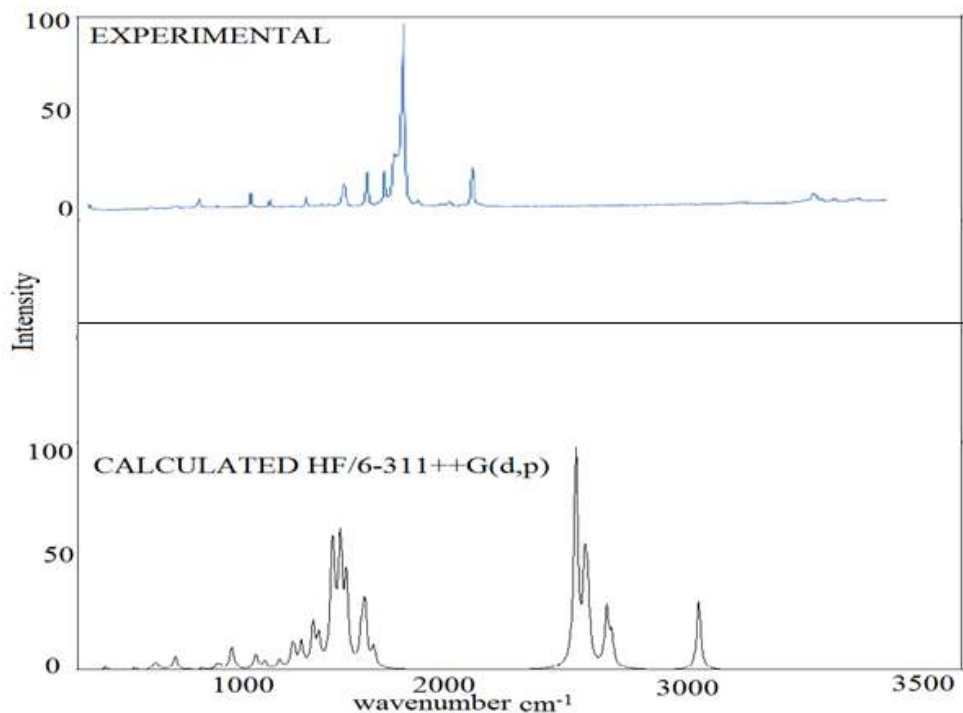

Figure 2: Comparative graph of IR intensities of compound 26DM4NP.



**Figure 3:** Comparative graph of Raman intensities of compound 26DM4NP

**Table 3.** Comparative values of IR intensities, Raman activities, Depolarisation ratios, reduced mass and Force constants of 2,6 Dimethyl-4-nitrophenol.

S.No.	Species	IR intensity	Raman Activity	Reduced mass	Force Constant
		HF/6-311++ (d,p)	HF/6-311++ (d,p)	HF/6-311++ (d,p)	HF/6-311++ (d,p)
1	A'	126.82	68.22	1.07	11.08
2	A'	0.64	31.31	1.09	7.39
3	A'	2.41	63.10	1.09	7.39
4	A'	14.06	55.96	1.10	6.87
5	A'	20.84	57.51	1.10	6.89
6	A'	19.72	76.55	1.10	6.79
7	A'	25.14	77.88	1.10	6.63
8	A'	30.50	190.57	1.04	6.17
9	A'	35.57	184.50	1.04	6.09
10	A'	248.89	0.81	9.40	18.54
11	A'	58.35	85.53	5.82	10.84
12	A'	327.93	13.12	9.20	16.94

S.No.	Species	IR intensity	Raman Activity	Reduced mass	Force Constant
		HF/6-311++ (d,p)	HF/6-311++ (d,p)	HF/6-311++ (d,p)	HF/6-311++ (d,p)
13	A'	5.89	13.15	2.00	3.19
14	A'	4.80	14.30	1.38	2.14
15	A''	291.86	153.84	2.53	3.88
16	A''	7.92	9.56	1.04	1.59
17	A'	7.91	8.18	1.04	1.57
18	A'	46.40	7.47	2.69	3.99
19	A'	294.89	37.07	2.34	3.41
20	A'	7.03	7.98	1.30	1.83
21	A'	2.74	7.52	1.26	1.76
22	A'	33.21	2.52	1.48	1.76
23	A'	162.90	45.29	3.19	3.74
24	A'	19.88	9.20	5.01	5.43
25	A'	24.29	3.81	1.76	1.85
26	A'	46.55	0.75	2.39	2.32
27	A'	93.64	24.19	1.67	1.46
28	A'	0.16	0.13	1.49	1.19
29	A'	0.67	0.18	1.49	1.17
30	A''	3.86	3.35	1.63	1.18
31	A''	12.18	1.52	1.78	1.27
32	A'	23.89	10.21	5.75	3.70
33	A'	24.65	0.05	1.36	0.85
34	A''	0.92	0.02	1.30	0.81
35	A''	11.44	0.30	3.38	2.04
36	A'	12.84	0.35	7.95	3.87
37	A'	17.31	1.58	9.71	3.88
38	A''	37.90	18.52	5.50	2.06
39	A''	13.76	0.32	5.55	5.55
40	A'	8.33	2.11	3.60	0.90
41	A'	0.98	2.30	6.24	1.33
42	A''	1.50	0.00	3.73	0.75
43	A'	9.07	11.98	4.85	0.89
44	A''	0.13	0.49	3.28	0.56
45	A'	3.78	4.49	6.17	0.79

S.No.	Species	IR intensity	Raman Activity	Reduced mass	Force Constant
		HF/6-311++ (d,p)	HF/6-311++ (d,p)	HF/6-311++ (d,p)	HF/6-311++ (d,p)
46	A'	0.21	2.49	10.20	0.92
47	A''	5.14	1.52	6.11	0.50
48	A''	4.28	0.10	3.89	0.28
49	A'	87.91	0.36	1.28	0.07
50	A'	1.88	0.77	2.69	0.14
51	A''	25.65	2.26	2.17	0.08
52	A'	2.47	0.06	5.75	0.16
53	A''	0.34	0.06	1.15	0.02
54	A''	0.00	0.07	2.62	0.04
55	A''	0.00	0.28	1.15	0.02
56	A''	1.12	0.28	3.47	0.03
57	A''	0.02	0.74	11.26	0.02

### THERMODYNAMIC PROPERTIES

The variation in Zero-Point Vibrational Energies (ZPVEs) seems to be significant. The values of some thermodynamic parameters (such as zero-point vibrational energy, thermal energy, specific heat capacity, rotational constants, entropy, and dipole moment) of 26DM4NP are calculated by HF 6-311++G(d,p) method at 298.15 K and 1.00 Atm pressure are listed in the Table4. All the thermodynamic data supply helpful information for the further study on the 26DM4NP. They can be used to compute the other thermodynamic energies according to relationships of thermodynamic functions and estimate directions of chemical reactions according to the second law of thermodynamics in Thermo chemical field (46-48).

**Table 4:** Theoretically computed energies (a. u.), zero point vibrational energies (kcal/ mol), rotational constants (GHz), entropies (cal/mol-Kelvin), dipole moment (Debye's), thermal energy(kcal/mol) and specific heat(cal/mol-Kelvin) for 2,6-Dimethyl-4-NitroPhenol.

PARAMETER	HF/6-311G(d,p)	DFT/B3LYP/6-311G(d,p)
Total Energy	-587.089097	-590.619614
Zero-Point Energy	108.89279	101.38089
Rotational Constants	1.57086	1.54898
	0.69557	0.68259
	0.48497	0.47660
Dipole Moment	5.4837	6.1307
ENTROPY		
Total	102.193	105.125

PARAMETER	HF/6-311G(d,p)	DFT/B3LYP/6-311G(d,p)
Translational	41.248	41.248
Rotational	30.785	30.834
Vibrational	30.160	33.043
ENERGY (THERMAL ENERGY)		
Total	115.687	108.595
Translational	0.889	0.889
Rotational	0.889	0.889
Vibrational	113.910	106.818
SPECIFIC HEAT C <sub>v</sub>		
Total	39.897	42.574
Translational	2.981	2.981
Rotational	2.981	2.981
Vibrational	33.936	36.613

## CONCLUSION

In the present work, an attempt has been made on the experimental and theoretical Vibrational spectral studies, NLO properties and thermodynamic properties at various temperatures of industrially important 2,3,4-CDMB. Equilibrium geometries, electronic parameters and thermodynamic parameters of 2,3,4-CDMB have been analyzed at HF using 6-311G++(d,p) basis sets. The correlations between the thermodynamic parameters and temperature show the increase in the heat capacities, entropies and enthalpies with increasing temperature owing to the rise in intensities of the molecular vibrations. Overall, the HF calculations on the molecule provided deep insight into their electronic structures and properties. In addition, the calculated vibrational results and thermodynamic functions are all in good agreement with the experimental data. The predicted NLO properties show that the title compound is a good candidate as nonlinear optical material.

## REFERENCES

- [1] J.H.S. Green, D.J. Harrison, *Spectrochimica Acta A* 27 (1971) 93.
- [2] R.K. Rai, *Proceedings of Indian Academy of Science Section A* 55 (1962) 232.
- [3] J.H.S. Green, *Spectrochimica Acta A* 18 (1962) 39.
- [4] J.C. Evans, *Spectrochimica Acta A* 16 (1960) 1382.
- [5] H.D. Bist, J.C.D. Brand, D.R. Williams, *Journal of Molecular Spectroscopy* 24 (1967) 402.
- [6] B.S. Bhal, A. Bhal, *Advanced Organic Chemistry*, fourth ed., S.Chand and company, 1995
- [7] R.J. Jakobsen, *Spectrochimica Acta A* 21 (1965) 433.
- [8] R.J. Jakobsen, *Spectrochimica Acta* 21 (1965) 433.
- [9] N.I. Davy Dova, I.A. Zhigunova, L.A. Ignateva, M.A. Kovner, *Optika i Spektroskopiya* 56 (1965) 1077.
- [10] J.H.S. Green, D.J. Harrison, W. Kynaston, *Spectrochimica Acta* 27A (1971).
- [11] J.C. Evans, *Spectrochimica Acta* 16 (1960) 1352.
- [12] A.E. Stanevich, *Optika i Spektroskopiya* 16 (1964) 781.
- [13] R.J. Jakobsen, E.J. Brewer, *Applied Spectroscopy* 17 (1962) 32.



- [14] Y. Kishore, S.N. Sharma, C.P.D. Dwivedi, *Indian Journal of Physics* 48 (1974) 412
- [15] Z. Zhengyu, Fu. Aiping, Du. Dongmei, *Journal of Quantum Chemistry* 78 (2000) 186–189
- [16] A.D. Becke, *Physics Review A* 38 (1988) 308–3101.
- [17] C. Lee, W. Yang, R.G. Parr, *Physics Review B* 37 (1988) 785–790.
- [18] J. Zhang, H.M. Xiao, *Journal of Chemical Physics* 116 (2002) 10674.
- [19] X.J. Xu, H.M. Xiao, X.H. Ju, X.D. Gong, W.H. Zhu, *Journal of Physical Chemistry A* 110 (2006) 5929.
- [20] Z.X. Chen, J.M. Xiao, H.M. Xiao, Y.N. Chiu, *Journal of Physical Chemistry A* 103 (1999) 8062.
- [21] Gaussian 09 Program, (Gaussian Inc., Wallingford CT), 2000.
- [22] M.J. Frisch, A.B. Nielsen, A.J. Holder, *Gauss View Users Manual*, Gaussian Inc., Pittsburgh, PA, 2000.
- [23] G. Socrates, *Infrared and Raman Characteristic Group Frequencies – Tables and Charts*, Third ed., Wiley, New York, 2001.
- [24] V. Krishnakumar, V. Balachandran, T. Chithambarathann, *Spectrochimica Acta part A* 62 (2005) 918–925.
- [25] W.O. George, P.S. McIntyre, *Infrared Spectroscopy*, John Wiley & Sons, London, 1987.
- [26] J. Coates, R.A. Meyers, *Interpretation of Infrared Spectra: A Practical Approach*, John Wiley and Sons Ltd, Chichester, 2000.
- [27] V. Krishnakumar, N. Prabavathi, *Spectrochimica Acta Part A* 71 (2008) 449–457.
- [28] A. Altun, K. Golcuk, M. Kumru, *Journal of Molecular Structure (Theochem)* 637 (2003) 155.
- [29] S.J. Singh, S.M. Pandey, *Indian Journal of Pure and Applied Physics* 12(1974) 300–305.
- [30] D.N. Sathyanarayana, *Vibrational Spectroscopy–Theory and Applications*, second ed., Newage International (P) Limited Publishers, New Delhi, 2004.
- [31] G. Lithivinov, *Proceedings of the 13th International Conference on Raman spectroscopy*, Weizburg, Germany, 1992
- [32] K. Furic, V. Mohacek, M. Bonifacic, I. Stefanic, *Journal of Molecular Structure* 267 (1992).
- [33] A. Altun, K. GoIcuk, M. Kumru, *Journal of Molecular Structure (Theochem)* 625 (2003) 17–23.
- [34] J.R. Durig, M.M. Bergana, H.V. Phan, *Journal of Raman Spectroscopy* 22 (1991) 141–145.
- [35] V. Krishna kumar, R. John Xavier, *Indian Journal of Pure and Applied Physics* 41 (2003) 5–99.
- [36] D.N. Sathyanarayana, *Vibrational Spectroscopy Theory and Applications*, second ed., New Age International (P) Limited Publisher, New Delhi, 2004.
- [37] P.S. Kalsi, *Spectroscopy of Organic Compounds*, Wiley Eastern Ltd., New Delhi, 1993, pp. 117
- [38] R.L. Peesole, L.D. Shield, I.C. Mcwillam, *Modern Methods of Chemical Analysis*, Wiley, New York, 1976.
- [39] A.R. Prabakaran, S. Mohan, *Indian Journal of Physics* 63B (1989) 468–473.
- [40] N. Sundaraganesan, S. Ilakiamani, H. Saleem, P.M. Wojieehowski, D. Michalska, *Spectrochimica Acta Part A* 61 (2005) 2995.
- [41] S. George, *Infrared and Raman Characteristics Group Frequencies Tables and Charts*, third edition, Wiley, Chichester, 2001.
- [42] Jag Mohan, *Organic Spectroscopy Principles and Applications*, Narosa Publishing House, New Delhi, 2000.
- [43] T. Watanabe, T. Ebata, S. Tanabe, N. Mikami, *Journal of Chemical Physics* 105 (1996) 408–412.

- [44] J. Coates, Interpretation of infrared spectra: a practical approach, in: R.A. Meyers (Ed.), Encyclopedia of Analytical Chemistry, John Wiley & Sons Ltd, Chichester, 2000.
- [45] S. Ahmad, S. Mathew, P.K. Verma, Indian Journal of Pure and Applied Physics 30 (1992) 764–770.
- [46] R. Zhang, B. Dub, G. Sun, Y. Sun, Spectrochimica Acta A 75 (2010) 1115– 1124.
- [47] Rajesh Kumar, Sarvendra Kumar, Jayant Teotia, M.K.Yadav, Journal of Advances in Physics, 8(2) (2015), 2122-2134.
- [48] Jayant Teotia, Sarvendra Kumar, Surbhi, Rajesh Kumar, M.K.Yadav, Asian Journal of Chemistry, 28(10) (2016), 2204-2210.

# Studies on Solidification Behaviour of Some Pure Components, Eutectics and Adducts

ASHOK KUMAR SINGH<sup>1</sup> AND PIYUS KUMAR PATHAK<sup>2</sup>

## Abstract

*The solidification behaviour of a material is responsible for its nature and applicability to technological and commercial applications. The solidification behaviour is governed by its mode which depends upon the nature of melt, cooling rate and its prehistoric conditions. For this purpose velocity of crystallization,  $u$  and  $n$  values for pure components Phenothiazine and Trinitroresol, eutectics and adducts have been determined. It is found that the crystallization behaviour follows Hillig – Turnbull equation. The phenomenon can be explained by Winegard mechanism.*

## INTRODUCTION

Solidification and melting are the transformations between crystallographic and non-crystallographic states of metals and alloys. These transformations are basic to single crystal growth for semi-conductors and directionally solidified composite materials<sup>1-2</sup>. Eutectics of solidification<sup>3-5</sup> comprises simultaneous deposition of two solid phases from a single liquid solution. After nucleation many eutectic grains grow more or less perpendicular to the solidification front. The front propagates at a very high speed but the liquids offer extra-ordinary resistance to the initiation of crystallization of eutectic. The rate of crystallization depends on the frequency of appearance of crystallization centers and on the rate of propagation of crystal liquid interface from these centres<sup>6</sup>. The growth laws for various known mechanisms have been reviewed by Tiller<sup>7</sup>. In pure components as well as in various organic eutectics lateral and normal growth mechanisms have been discussed<sup>8</sup>. Normal growth generally occurs on the rough interface while lateral growth is facilitated by the presence of steps and bends etc. Hillig and Turnbull<sup>9</sup> suggested relation between continuous growth rate ( $v$ ) and undercooling ( $\Delta T$ ) as  $v = u(\Delta T)^n$  where  $u$  and  $n$  are constants whose values are calculated for various organic eutectic systems. In the theories<sup>10</sup> giving insight into the solidification phenomenon,  $n$  is found close to 2. Mollard and Flemming<sup>11</sup> defined the criteria for eutectic plane- front growth in binary system containing a eutectic.

---

<sup>1</sup> Department of Chemistry, Harish Chandra P.G. College, Varanasi,  
E-mail: ashok.singh126.as@gmail.com

<sup>2</sup> United College of Engineering and Research, Greater Noida, U.P.

### Materials and Method

The experimental procedure of linear velocity of crystallization have been determined as the work done by author<sup>12</sup>. ( Page 40)

**Table 1.** Linear velocity of crystallization of pure Phenothiazine MP 182°C

<i>Under cooling(ΔT)0C</i>	<i>log ΔT</i>	<i>Velocity of crystallization (V) mm/sec</i>	<i>logV</i>
1.479	0.17	0.7413	-0.13
1.862	0.27	0.9333	-0.03
2.512	0.40	1.202	-0.08
3.162	0.50	1.479	0.17
3.081	0.60	1.820	0.26
5.012	0.70	2.239	0.35

**Table 2.** Linear velocity of crystallization of pure Trinitrocresol MP 108.5°C

<i>Under cooling(ΔT)0C</i>	<i>log ΔT</i>	<i>Velocity of crystallization (V) mm/sec</i>	<i>logV</i>
2.089	0.32	0.2884	-0.54
3.090	0.49	0.4365	-0.36
4.571	0.66	0.6918	-0.16
7.586	0.88	1.148	0.06
11.75	1.07	1.950	0.29

**Table 3.** Linear velocity of crystallization of Eutectic 1 MP 98.7°C at mole % 6.9 of Phenothiazine

<i>Under cooling(ΔT)0C</i>	<i>log ΔT</i>	<i>Velocity of crystallization (V) mm/sec</i>	<i>logV</i>
1.380	0.14	0.8128	-0.09
1.095	0.28	1.148	0.06
2.745	0.44	1.622	0.21
3.715	0.57	2.188	0.34
4.786	0.68	2.851	0.47

**Table 4.** Linear velocity of crystallization of Eutectic 2 MP 132.3°C at mole % 82.7 of Phenothiazine

<i>Under cooling(Δ T)0C</i>	<i>log ΔT</i>	<i>Velocity of crystallization (V) mm/sec</i>	<i>LogV</i>
1.445	0.16	0.5495	-0.26
2.138	0.33	0.7762	-0.11
3.631	0.56	1.175	0.07
7.586	0.88	1.738	0.24
10.0	1.0	2.638	0.43

**Table 5.** Linear velocity of crystallization of addition compound, MP 159.9°C at mole % 50 of Phenothiazine

<i>Under cooling(ΔT)0C</i>	<i>log Δ T</i>	<i>Velocity of crystallization (V) mm/sec</i>	<i>LogV</i>
2.951	0.47	0.2692	-0.57
4.786	0.68	0.4169	-0.38
8.511	0.93	0.6761	-0.17
9.333	0.97	1.047	0.02
10.47	1.02	1.549	0.19

**Table 6.** Values of u and n for pure components, eutectics and addition compounds

<i>System</i>	<i>u mm/s/0C</i>	<i>n</i>
Phenothiazine	1.0081	3.02
Trinitroresol	0.0033	1.99
E1	0.0042	2.11
E2	0.0058	1.59
1:1 Addition compound	0.0060	2.05

## RESULTS AND DISCUSSION

The log v was plotted against ΔT using Hillig- Turnbull equation  $v=u(\Delta T)^n$  where v is the linear velocity of crystallization, ΔT is undercooling, u and n are constants. On comparing value of u for the phenothiazine- trinitroresol system, it is observed that addition compound crystallizes slower than phenothiazine and faster than trinitroresol. The plot of log v against log ΔT gives straight line indicating the validity of Hillig-Turnbull equation. It has been observed that value of n for eutectics is very close to 2 indicating square relationship between growth velocity and undercooling. The deviation in value of n from 2 is due to difference between the bath temperature and temperature of growing interface. In the system taken the eutectics E<sub>1</sub> and E<sub>2</sub> are slower than phenothiazine but faster than trinitroresol. However E<sub>2</sub> solidifies faster than E<sub>1</sub>. The result may be explained on the basis of Winegard<sup>13</sup> mechanism and the solidification of the system adopts side by side nucleation.

## REFERENCES

- [1] V.Laxmanan, J.Crystal Growth 83 (1987) 391.
- [2] Elliot, R, "Eutectic solidification processing". Butter Worths , London (1983).
- [3] U.S. Rai and H. Shekhar, Cryst. Res. Techno. 29(1994) 551.
- [4] Ramalingam, A., Karunanithy, D., et al., FTIR spectral studies of Pure L-Arginine phosphate crystal, Acta Ciencia Indica Vol. XXXV C, No. 1,p. 121-124 (2009).

- [5] Soni S.V. and Soni, Mrs Sunita, Growth of pure and Na<sup>+</sup> doped T.G.S. crystals, *Acta Ciencia Indica* Vol. XXXV C, No. 1 ,p141-144 (2009).
- [6] Podolinski , V.V. and Drykin , V.G. *Krystallographiya* 35 , 1309 (1990).
- [7] Tiller , W.A. , *Treatise on materials science research* , edited by H. Harman , Academic Press , New York (1972).
- [8] Singh, N.B. and Dwivedi K.D. , *J.Sci. , Indi. Res. ,* 41 , 98 (1982).
- [9] Hillig W.B. and Turnbull D. , *J. Chem.Phys. ,* 24 , 914 (1956)
- [10] Bassi P.S. , Sharma R.P. and Khurana J.R. , *Indian J. Technol* 29(3) , 115(1991).
- [11] Molard F.R. and Flemming M.C. *Trans. Met. Soc. AIME*,239,1526(1967).
- [12] Reference thesis by Singh A.K. and Singh N.P. Purvanchal University Jaunpur ,  
“Characterization and induction of some novel character in some composite materials of organic origin” p.p. (2000).
- [13] Winegard W.C. , Majaka S.Thall , B.M. and Chalmers , B., *Can. J. Chem*, 29,320(1951).

# Futuristic Technology: Screenless Display

PRIYANKA GUPTA<sup>1</sup> AND HIMANSHI GUPTA<sup>1</sup>

## Abstract

*This paper discusses about a new developing technology i.e. Screenless Display, has become a good vision in future for wide area of applications. As the name implies it deals with the display of several things without the use of screens using projector. Using this technology we can direct project images at the human eye retina, human brain or free space. In this paper we will discuss about its concepts, working and its applications in different areas also. This technology contains three different working principles – The Visual Image, Virtual Retinal Display and Synaptic Interface. This computing technology would bring a revolution in the field of displays and monitors which are highly expensive, consume high power and it will prove as futuristic revolutionary technology.*

**Keywords:** *Visual Image, Synaptic Interface, Retinal Display, Hologram*

## INTRODUCTION

Technology always makes modifications in existing technologies and tools in order to solve problems and make life more comfortable. Screenless Display is one of the most interesting topic for researchers now-a-days. Few parts of this technology are using at present but not so advance yet. It is a revolutionary technology in the field of computer science and in coming future it will be a greatest development in display technology area.

Screenless Display is a technology which can be project image at anywhere, where the user wants to have a screen, like on a wall or in an open space etc. “Screenless video describes systems for transmitting visual information from a video source without the use of screen.”

Screenless computing system can be divided into three groups:

- (1) Visual Image
- (2) Retinal Direct Display
- (3) Synaptic Interface

## VISUAL IMAGE

Visual Image Screenless Display includes any image that eye can perceive. It is based on

---

<sup>1</sup> Department of CSE, MIET Greater Noida

E-mail: spam.always2010@gmail.com, himanshi.btech@gmail.com

the concept that light gets reflected by the intermediate object before it could reach to the retina. The intermediate object can be holograms, windows, or even LCDs. Example of this type of display is Displayers' air screen technology- The Displayers' air screen projects images onto sheets of water droplets suspended in air, giving the illusion of a hologram. Another example is google glass, which is virtual reality goggles. This technology is type of augmented reality visual image display that displays image right in front of our eye. Beside we have expanded in developing the displays for wearable contact lenses.



**Figure 1:** Visual Image

The most common example of Visual Image Screenless Display is Hologram.

## **HOLOGRAM**

A Hologram is not a image itself but it is a recording of a light field and displays a three dimensional image of the holographed subject. It displays an image that is reflected by the substance that can perceive by an eye.

This technique was mostly used in telecommunication in place of screens. Holograms could be displayed directly or could be store at many storage devices like holodiscs which can be hooked up with holoprojector and stored images can be access easily. Hologram provide high quality images and can be viewed by human eye directly and does not need any special lens or device.

## **WORKING OF HOLOGRAM**

It works on the interference of laser beam and object beam, when both of the beams get interacted then it creates a three dimensional image.



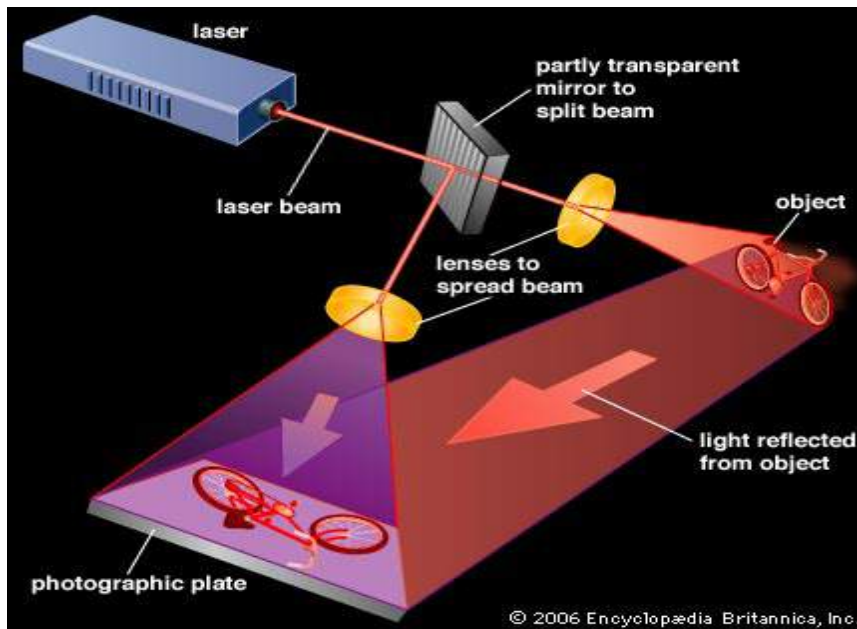

Figure 2: Working of Hologram

## RETINAL DISPLAY

Retinal Display is a category of screenless display in which images are direct projected on the retina of the human eye and this makes it different from Visual Image because in this technology light is not reflected from any intermediate object onto the retina. It can create an illusion that for viewer, like viewing an image from many feet away and clearer view of any object.

Glyph also developed a Virtual Retinal Display.

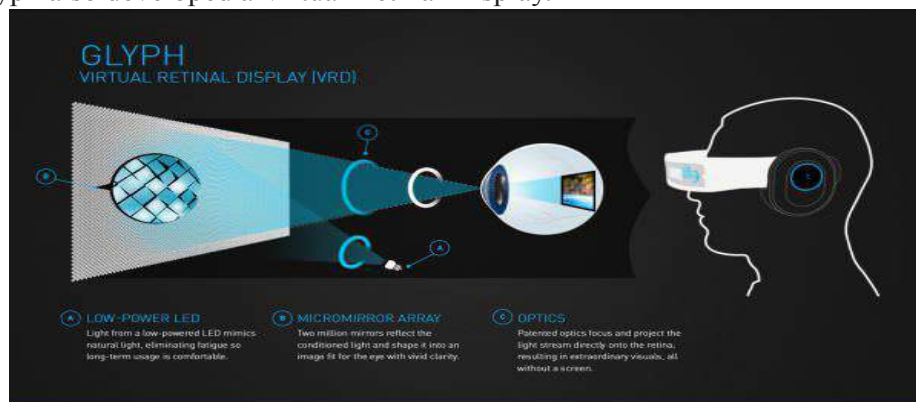

Figure 3: Retinal Display

## SYNAPTIC INTERFACE

Synaptic Interface Screenless Display displays the image onto the brain directly which makes it different from Visual Image and Retinal Display. It displays by transmitting the signals directly into the brain through the optic nerve, no lights included, only electric impulses. It does not display images on retina or in free space.

This method is tested on horseshoe crabs by the recording of their brain nerve images. Further the neural code transmitted to the brain by the optic nerve. This technology gives the possibility of providing sight for the blind people by using implanted electronics to bypass nonfunctional parts of the eye. It can give users the benefit to view images in greater coordination and complexity than the eyes capable of producing. However the method requires more research and development for further production of worldwide application can be implemented.



**Figure 4:** Synaptic Interface

## APPLICATIONS OF SCREENLESS DISPLAY

- Corporations
- Businesses
- Health-care systems
- Institutions
- Organizations

## CONCLUSION

In this paper we discussed about Screenless Displays which is one of the most revolutionary technologies. Screenless Display will give a brighter future to the computer technology area. Still this topic needs more research, plenty of knowledge for the more development. In the future the whole world may be dominated with the Screenless Display Technology.

# Current Role of Neem (*Azadirachta indica*) as per Pharmacology and Pharmaceutical Carrier: A Review

SANDEEP KUMAR<sup>1</sup>, OM KUMAR<sup>2</sup>, ABHA AHLAWAT<sup>3</sup> AND LALITA PAYAL<sup>3</sup>

## ABSTRACT

*Azadirachta indica* is an evergreen tree found mainly in India, it has been used in different medicinal systems: Ayurveda, unani, homeopathic therefore considered as cynosure of modern medicine. *Azadirachta indica* (NEEM) in world is matched with available literature. Recent years, especially of plant origin received much attention as they are well tested for their efficiency and generally believed to be safe for human use. Thorough screening of literature available on *Azadirachta indica* depicted the fact that it is a popular remedy among the various ethnic groups, **Unani, Ayurvedic** and traditional practitioners for treatment of ailments. Researchers are exploring the therapeutic potential of this plant as it has more therapeutic properties which are not known. The present paper reviews the current role of Neem as per pharmacology and pharmaceutical carrier.

**Keywords:** Therapeutic Potential, Unani, Ayurvedic

## INTRODUCTION

Neem is an attractive broad-leaved, evergreen tree which can grow up to 30m tall and 2.5m in girth. Its trunk usually straight is 30-80 cm in diameter. Its spreading branches form a rounded crown of deep-green leaves and honey-scented flowers as much as 20m across.

## MEDICINAL USE

All parts of tree have been used medicinally for centuries. It has been used in Ayurvedic medicine for more than 4000 years due to its medicinal properties. The earliest Sanskrit medical writings refer to the benefits of Neem's fruits, seeds, oil, leaves, roots and bark. Each has been used in the Indian Ayurvedic and Unani medicine and now being used in pharmaceutical and cosmetics industries.

---

<sup>1</sup> Department of Applied Science, BBDIT Ghaziabad  
E-mail: Sandeep\_chemistry@yahoo.com

<sup>2</sup> D N (PG) College, Meerut

<sup>3</sup> Department of Physics, S G (PG) College Sarurpur Khurd Meerut

## THERAPEUTIC USES

Hot water extract of the bark is taken orally by the adults females as a tonic and emmenagogue. **Anthraquinone** fraction of dried flower, fruits and leaf is taken orally for leprosy. Hot water extract of the flower and leaf is taken orally as an anti-hysterical remedy and used externally to

treat wound. The dried flower is taken orally for diabetes. Hot water of dried fruit is used for piles and externally for skin disease and ulcers. Hot water extract of the entire plant is used as anthelmintic, an insecticide and purgative. Juices of bark **Andrographis paniculata**, **Azadirachta indica**, **Tinospora cardifolia**, are taken orally as a treatment for filariasis. The hot water extract is also taken for fever, diabetes, and as a tonic refrigerant, athermintic. Leaves due to insecticidal properties are kept with woolen and other cloths for long time. Leaf juice is given in gonorrhoea and leucorrhoea. Leaves applied as poultice to relieve boils, their infusion is used as antiseptic wash to promote the healing of wound and ulcers. A paste of leaves is used to treat wounds, ring worms, eczema and ulcers. Bathing with Neem leaves is beneficial for itching and other skin disease. Leaf juice is used as nasal drop to treat worm infestation in nose. The tender twigs of the tree are used as tooth brush which is believed to keep the body system healthy, the breath and mouth clean and sweet. Seed oil is used in leprosy, syphilis, eczema, chronic ulcers.

## ANTIDIABETIC EVALUATION

The pharmacological hypoglycemic action of Neem has been examined in diabetic rats. After 24 hrs treatment, Neem 250mg/kg, reduced glucose (15%), cholesterol (15%), triglycerides (32%), Urea (13%), creatinine (23%) and lipids (15%). Multiple dose study for 15 days also reduced creatinine, urea, lipids, triglycerides and glucose. In glucose tolerance test in diabetic rats with neem extract 250mg/kg demonstrated glucose levels were significantly less compared to the control group. *Azadirachta indica* significantly reduces glucose levels at 15<sup>th</sup> day in diabetic rats.

## Antioxidant

Extracts from young flowers and leaves have strong antioxidant potential. An indicator of oxidative stress, malondialdehyde (MDA) was reduced by 46.0% and 50.6% for flower and leaf-based extracts, respectively, prompting the recommendation to use Neem as a vegetable bitter tonic to promote good health.

## Anti-HIV/AIDS

In HIV/AIDS patients, a 12-week oral administration of acetone water neem extract (IRAB) had a significant influence in vivo on CD4 cells (which HIV reduces) without any adverse effects in the patients. Of the 60 patients who completed treatment, 50 were completely laboratory-test compliant. The mean levels of CD4 cells increased by 159% in 50 patients, which is a major increase; the no. of HIV/AIDS significant increases were experienced in body weight (12%), hemoglobin concentration (24%), and lymphocyte differential count (24%).

**Antiulcer**

Neem bark extract reduced human gastric acid hypersecretion, and gastro-esophageal and gastroduodenal ulcers.

**Anti-Tumour Effect**

A study on Neem has revealed a chemo preventive capability by regressing the hepatocarcinogenesis induced by diethyl Nitrosamine (DEN) / 2 Acetylaminofluorence (AAF) carcinogens on Spraque- Dawly rats.

**Antifertility Effect**

Neem and seed extracts administered orally at the beginning of post-implantation stage resulted in pregnancy termination in rodents and primates, without permanent effect.

**Antihypertensive And Antihypercholesteremic Effect**

Administration of aqueous extract of neem along with DOCA salt prevented the development of hypertension in rats. Administration of mature leaf extract decreased serum cholesterol significantly without changing serum protein, protein urea and uric acid levels in rats.

**ROLE IN HEALTH CARE**

With the rise in healthcare costs, after effects of pharmaceuticals and synthetic products, natural and herbal products are in great demand all over the world. Neem has for long been known to have innumerable health benefits, it has traditionally been used to maintain good skin, strong teeth, keep digestive problems at bay, prevent heart diseases and diabetes. As consumer re learn the benefits of the 'universal tree', they are moving towards all natural health products with high efficacy and more safety.

- Medicines and Drugs : Curing almost all diseases in traditional medicine system and modern allopathic drugs.
- Neem Essential Oil : Used in aromatherapy for its calming and therapeutic value.
- Neem Tea : Used for its therapeutic value.
- Neem Hair Products : Hair conditioners, shampoo, hair growth lotions.
- Neem Skin Products : Creams, lotions

Benefits of Neem Health Care Products 100% natural.

**CURRENT ROLE IN COSMETIC INDUSTRY**

Last few decades have witnessed a great demand for herbal cosmetic products, away from synthetics, this so, because these herbal and natural cosmetics are safe to use and do not have any side effects. Neem tree is being extensively used in powdered form, extracts, raw form to manufacture quality products the world over.

With man relearning the benefits of natural products, neem is increasingly being used by leading herbal cosmetic manufacturers right from body lotions to face packs, from skin cleansers to fairness creams.

Herbal cosmetics are the current rage not only in Asian countries like India, but also countries like US, UK and Australia. The herbal premium cosmetic sector is growing at 15% P.A and this in turn poses good opportunity for neem manufacturers and exporters to make quality natural cosmetics to meet the ever increasing demand the world over.

There has been a metamorphosis in the cosmetic industry with natural products being more in demand than their synthetic counterparts; this has been possible because of the shift in consumer preference from synthetic cosmetics to natural ones.

Neem will be in huge demand for manufacturing a range of cosmetics in the coming time. With the increase in learning about traditional methods like Ayurveda, Unani etc, this universal tree will find a place in quite a few skin and body care products. Neem powder mixed with other powdered natural ingredients such as rose and sandalwood are being used as an effective cure for blemish and acne preventing powders, lotions and creams.

### **ROLE WITH TRADITIONAL MEDICINE INDUSTRY**

Neem has essentially been used for centuries now, in different traditional medicine systems like Ayurveda and Unani system. It is used to manufacture large variety of drugs, medicines, tonics, syrups addressing different diseases.

### **CARRIER OF NEEM IN AYURVEDA AND HERBAL INDUSTRY**

Neem is extensively used to manufacture a large number of ayurvedic medicines and syrups as they have curative properties to treat all doshas. It is a major ingredient used and referred by all ayurvedic practitioners due to its miraculous powers. It is being used to manufacture natural products like:

- Dietary Supplements
- Skin Care Products
- General health care products
- Oral Care products
- Blood Purifying and detoxifying products

Healers use the roots, bark, gum, leaves, fruit, seed kernels and seed oil for preparations that heal and prevent disease throughout the human body.

This is a lucrative opportunity for neem products manufacturers to supply quality extracts, raw neem to ayurvedic and other traditional medicines manufacturers. The main reason for the popularity of neem is the fact that not only can it be used to cure a number of defects simultaneously, but it also has no side effects.

### **FUTURE OF NEEM IN UNANI MEDICINE**

Unani system is one of the oldest system of medicine being used in the Indian Subcontinent and other countries. It is based on the Greek philosophy. Neem has been an active participle in a large number of unani medicines in the raw form or as concentrated extracts to cure skin disorders, digestive disorders, dental problems, diabetic and blood related problems. With the increase in the belief of efficacy and goodness of natural products and medicines,

neem tree has been gaining popularity as a sure shot cure for a wide number of diseases without any after effects.

### **NEEM SIDE EFFECTS**

Neem products have been used by households for personal consumption in the form of cosmetics, medicines, dental products, skin care products for a long time, they are also increasingly used in animals such as animal feeds, animal medicines etc. Many people assume that neem being natural is automatically free of side effects. But it is wise to consider that any natural product with medicinal properties is capable of causing certain side effects. Traditional Ayurvedic doctors did not advise the use of neem if the person suffers from fatigue .

### **NEEM SIDE EFFECTS**

The possible side effects of neem included:

- Kidney damage.
- Low or no urine production.
- Liver damage.
- Yellow skin (jaundice).
- Destruction of red blood cells.
- Allergic reaction like rash, itching, swelling of the throat or mouth, wheezing.
- Difficulty breathing.

### **NEEM SIDE EFFECTS IN CHILDREN**

Neem seems to be fairly toxic to children. The reported side effects of neem in children are as follows:

- Loose stools
- Vomiting
- Acidic blood
- Drowsiness
- Anemia
- Seizures
- High levels of white blood cells
- Loss of consciousness
- Brain swelling
- Coma
- Loss of life

### **NEEM LEAF SIDE EFFECTS**

No neem leaf side effects have been noticed. But yes if you want to conceive and it is applicable to both men and women. Never consume neem leaf or any neem product during fever. Also never consume neem oil. Never spray neem oil if you have pets and kids at home. Very harsh neem oil effects have been reported in case of children. Some cases of death have also been reported. So once again never consume neem oil. Also neem leaves should be taken in moderation.

### Note: Preventive Tips

Be sure to seek immediate medical attention if you think you may be having an allergic reaction to neem.

Though neem insecticides and **pesticides** do not have any side effects but use in large quantities might possibly have certain negative effects. Numerous studies of possible toxicity of neem have led to a conclusion that leaf and bark of the tree are quite low in toxicity. It has been reported that large quantities of neem seed, leaf consumption has led to certain side effects in animals. According to research conducted by USA and other countries, neem oil extracts have found to be safe, if taken in limited dosage over a period of time. Personal allergy to neem should be tested at the onset of neem use. It is not recommended to pregnant or nursing women to use neem. Avoid using neem supplements on children. as fig 1.

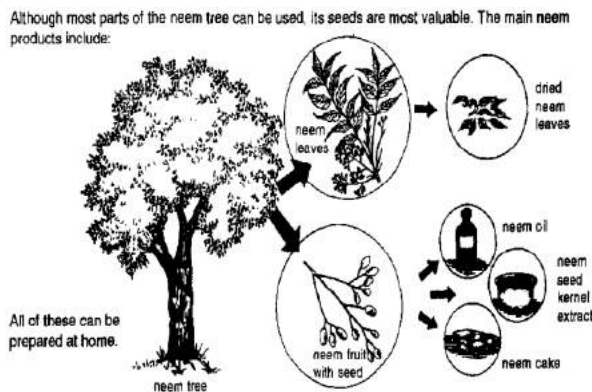

Figure 1

### CONCLUSION

The above collected regarding the use of *Azadirachta indica* (NEEM) in world is matched with available literature. Recent years, especially of plant origin received much attention as they are well tested for their efficiency and generally believed to be safe for human use. Thorough screening of literature available on *Azadirachta indica* depicted the fact that it is a popular remedy among the various ethnic groups, **Unani**, **Ayurvedic** and traditional practitioners for treatment of ailments. Researchers are exploring the therapeutic potential of this plant as it has more therapeutic properties which are not known. We cannot ignore the benefits of neem just because it has certain side effects. Neem is no doubt the wonder



tree which has been providing many medicinal benefits which cannot be ignored. It is possible that you may experience some or none of the neem side effects mentioned above.

## **BIBLIOGRAPHY**

- [1] Rao BS, Nazma and Rao JM. *Curr Sci* 1977; 46:714–716.
- [2] [36] Butterworth JH and Morgan ED. *J Chem Soc Chem Commun* 1968; 23–24.
- [3] [37] Jones I, Ley SV, Denholm AA, Lovell H, Wood A and Sinden RE. *FEMS Microbiol Lett* 1994; 120:267–273.
- [4] [38] Vander Nat JM, Vander Sluis WG, t Hart LA, Van Disk H, de Silva KTD and Labadie RP. *Planta Med* 1991; 57:65–68.
- [5] [39] Ara I, Siddiqui BS, Faizi S and Siddiqui S. *J Chem Soc Perkin Trans* 1989; I: 343–345.
- [6] [40] Pant N, Garg HS, Madhusudanan KP and Bhakuni DS. *Fitoterapia* 1986; 57:302–304.
- [7] [41] Kakai Tokkyo Koho JP. *Chem Abstr* 1984; 100:91350.
- [8] [42] Fujiwara T, Takeda T, Ogihara Y, Shimizu M, Nomura T and Tomita Y, *Chem Pharm Bull* 1982; 30:4025–4030.
- [9] [43] Fujiwara T, Sugishita E, Takeda T, Ogihara Y, Shimizu M, Nomura T and Tomita Y. *ibid* 1984; 32:1385–1391.
- [10] [44] Vander Nat JM, Kierx JPAM, Van Dijk H, De Silva KTD and Labadie RP. *J Ethnopharmacol* 1987; 19:125–131.
- [11] [45] Vander Nat JM, Hart LAT, Vander Sluis WG, Van Dijk H, Vander Berg AJJ, De Silva KTD and Labadie RP. *ibid* 1989; 27:15–24.
- [12] [46] Moursi SAH and Al-Khatib IM. *Jpn J Pharmacol* 1984; 36:527–533.
- [13] [47] Dymock. *Pharmacogr Ind* 1890; 1:324.
- [14] [17] Kraus W. In *The Neem Tree: Source of Unique Natural Products for Integrated Pest Management, Medicine, Industry and Other Purposes* (ed Schmutterer H) 1995: 35–88.
- [15] [18] Devakumar C and SukhDev. In *Neem* (eds Randhawa and Parmar, B. S.) 1996; 2: 77–110.
- [16] [19] Govindachari TR. *Curr Sci* 1992; 63:117–122.
- [17] [20] Mitra CR, Garg HS and Pandey GN. *Phytochem* 1971; 10:857–864.
- [18] [21] Bhargava KP, Gupta MB, Gupta GP and Mitra CR. *I J Med Res* 1970; 58:724–730.
- [19] [22] Pillai NR and Santhakumari G. *Planta Med* 1981; 43:59–63
- [20] [23] David SN. *Mediscope* 1969; 12:25–27.
- [21] [24] Pillai NR and Santhakumari G. *I J Med Res* 1981; 74:931–933.
- [22] [25] Pillai NR and Santhakumari G. *Planta Med* 1984; 50:143–146.
- [23] [26] Pillai NR, Seshadri DS and Santhakumari G. *I J Med Res* 1978; 68:169–175.
- [24] [27] Pillai NR and Santhakumari G. *Ancient Sci Life* 1985; 5:91–97.
- [25] [28] Sharma VN and Saksena KP. *I J Med Res* 1959; 13:1038.
- [26] [29] Sharma VN and Saksena KP. *ibid* 1959; 47:322.
- [27] [30] Murthy SP and Sirsi M. *I J Physiol Pharmacol* 1958; 2:387–396.
- [28] [31] Bhide NK, Mehta DJ and Lewis RA. *I J Med Sci* 2008; 12:141–145.
- [29] [32] Rochanakij S, Thebtaranonth Y, Yenjal CH and Yuthavong Y. *Southeast Asian J Trop Med Public Health* 2010; 16:66–72.
- [30] [33] Khalid SA, Duddect H and Gonzalez-Sierra MJ. *J Nat Prod* 2012; 52:922–927.

# On Recurrent Lightlike Hypersurfaces of Indefinite Almost Hyperbolic Hermitian Manifold With Quarter-Symmetric Metric Connection

SHIKHA TIWARI AND SUSHIL SHUKLA<sup>1</sup>

## Abstract

*The object of present paper is to study the properties of recurrent lightlike hypersurfaces of indefinite hyperbolic Hermitian manifold with Quarter-symmetric metric connection.*

*Mathematics Subject Classification: 53C15, 53C25, 53C50*

**Keywords:** *Quarter-symmetric Metric Connection, Lightlike Hypersurface, Recurrent Lightlike Hypersurfaces*

## INTRODUCTION

The notion of quarter-symmetric metric connection on a semi-Riemannian manifold was introduced by Yano-Imai [6]. A linear connection  $\bar{\nabla}$  on a semi-Riemannian manifold  $(\bar{M}, \bar{g})$  is called quarter-symmetric connection if its torsion tensor  $\bar{T}$  satisfies  $\bar{T}(\bar{X}, \bar{Y}) = \pi(\bar{Y})\bar{J}\bar{X} - \pi(\bar{X})\bar{J}\bar{Y}$ , ... (1.1)

where  $J$  is a (1, 1)-type tensor field and  $\pi$  is a 1-form associated with a unit vector field  $\zeta$ , which is called the characteristic vector field, by  $\pi(\bar{X}) = \bar{g}(\bar{X}, \zeta)$ . Let us consider a differential manifold  $M_{2n}$  of class  $C^\infty$  endowed with a tensor field of type (1, 1)  $F$  such that for an arbitrary vector field  $X$ .

$$\bar{X} = X \quad \dots (1.2)$$

where  $\bar{X} \stackrel{\text{def}}{=} F(X)$  then  $F$  is called an almost hyperbolic Hermitian structure, and the differential manifold  $M_{2n}$  is called almost hyperbolic Hermitian manifold.

On almost hyperbolic Hermitian manifold  $M_{2n}$ , if there exists a symmetric metric tensor  $g$  such that,

$$g(\bar{X}, \bar{Y}) + g(X, Y) = 0, \quad \dots (1.3)$$

Then we say that  $g$  is compatible with almost complex structure and  $\{F, g\}$  is called an almost hyperbolic Hermitian structure. The manifold  $M_{2n}$  with an almost hyperbolic Hermitian structure is said to be an almost hyperbolic Hermitian manifold .

<sup>1</sup> Department of Applied Science (Mathematics), BBDIT, Gaziabad  
E-mail: ss123a@rediffmail.com

### LIGHTLIKE HYPERSURFACES

Let  $(M, g)$  be a lightlike hypersurface of  $\bar{M}$ . The normal bundle  $TM^\perp$  of  $M$  is a subbundle of the tangent bundle  $TM$  of  $M$ , of rank 1, and coincides with the radical distribution  $\text{Rad}(TM) = TM \cap TM^\perp$ . Denote by  $F(M)$  the algebra of smooth functions on  $M$  and by  $T(E)$  the  $F(M)$  module of smooth sections of any vector bundle  $E$  over  $M$ .

A complementary vector bundle  $S(TM)$  of  $\text{Rad}(TM)$  in  $TM$  is nondegenerate distribution on  $M$ , which is called a screen distribution on  $M$ , such that

$$TM = \text{Rad}(TM) \oplus \text{orth } S(TM),$$

where  $\oplus \text{orth}$  denotes the orthogonal direct sum. For any null section  $\xi$  of  $\text{Rad}(TM)$ , there exists a unique null section  $N$  of a unique lightlike vector bundle  $\text{tr}(TM)$  in the orthogonal complement  $S(TM)^\perp$  of  $S(TM)$  satisfying

$$\bar{g}(\xi, N) = 1, \quad \bar{g}(N; N) = \bar{g}(N; X) = 0; \quad \forall X \in T(S(TM));$$

We call  $\text{tr}(TM)$  and  $N$  the transversal vector bundle and the null transversal vector field of  $M$  with respect to the screen distribution  $S(TM)$ , respectively.

The tangent bundle  $T\bar{M}$  of  $\bar{M}$  is decomposed as follow:

$$T\bar{M} = TM \oplus \text{tr}(TM) = \{\text{Rad}(TM) \oplus \text{tr}(TM)\} \oplus \text{orth } S(TM):$$

In the sequel, let  $X, Y, Z$  and  $W$  be the vector fields on  $M$ , unless otherwise specified. Let  $P$  be the projection morphism of  $TM$  on  $S(TM)$ . Then the local Gauss and Weingarten formulas of  $M$  and  $S(TM)$  are given respectively by

$$\bar{\nabla}_X Y = \nabla_X Y + B(X, Y)N. \quad \dots (2.1)$$

$$\bar{\nabla}_X N = -A_N X + \tau(X)N, \quad \dots (2.2)$$

$$\nabla_X PY = \nabla_X^* PY + C(X, PY)\xi. \quad \dots (2.3)$$

$$\nabla_X \xi = -A_\xi^* X + \sigma(X)\xi, \quad \dots (2.4)$$

where  $\nabla$  and  $\nabla^*$  are the induced linear connections on  $TM$  and  $S(TM)$  respectively,  $B$  and  $C$  are the local second fundamental forms on  $TM$  and  $S(TM)$  respectively,  $A_N$  and  $A_\xi^*$  are the shape operators on  $TM$  and  $S(TM)$  respectively, and are 1-forms on  $TM$ .

For a lightlike hypersurface  $M$  of an indefinite almost Hermitian manifold  $(\bar{M}, \bar{g})$ , it is known [3] that  $J(\text{Rad}(TM))$  and  $J(\text{tr}(TM))$  are subbundles of  $S(TM)$ , of rank 1 such that  $J(\text{Rad}(TM)) \cap J(\text{tr}(TM)) = 0$ . Thus there exist two non-degenerate almost complex distributions  $Do$  and  $D$  on  $M$  with respect to  $J$ , i.e.,  $J(Do) = Do$  and  $J(D) = D$ , such that

$$S(TM) = J(\text{Rad}(TM)) \oplus J(\text{tr}(TM)) \oplus \text{orth } Do;$$

$$D = \{\text{Rad}(TM) \oplus \text{orth } J(\text{Rad}(TM))\} \oplus \text{orth } Do;$$

$$TM = D \oplus J(\text{tr}(TM)), \quad \dots (2.5)$$

Consider two null vector fields  $U$  and  $V$ , and two 1-forms  $u$  and  $v$  such that

$$U = -JN, \quad V = J\xi, \quad u(X) = g(X, V); \quad v(X) = g(X, U), \quad \dots (2.6)$$

Denote by  $S$  the projection morphism of  $TM$  on  $D$ . Any vector field  $X$  of  $M$  is expressed as  $X = SX + u(X)U$ . Applying  $J$  to this form, we have

$$JX = FX + u(X)N, \tag{2.7}$$

where  $F$  is a tensor field of type  $(1, 1)$  globally defined on  $M$  by  $F = JoS$ . Applying  $J$  to (2.7) and using (1.2), (1.3) and (2.6), we have

$$F^2X = X - u(X)U: \tag{2.8}$$

As  $u(U) = 1$  and  $FU = 0$ , the set  $(F, u, U)$  defines an indefinite almost contact structure on  $M$  and  $F$  is called the structure tensor field of  $M$ . But it is not an indefinite almost contact metric structure on  $M$  and satisfies

$$g(FX; FY) = g(X, Y) - u(X)v(Y) - u(Y)v(X): \tag{2.9}$$

Denote by  $\bar{R}$ ,  $R$  and  $R^*$  the curvature tensor of the quarter-symmetric metric connection  $\bar{\nabla}$  on  $\bar{M}$  and the induced linear connection  $\nabla$  and  $\nabla^*$  on  $M$  and  $S(TM)$  respectively. Using the Gauss-Weingarten formulas, we obtain two Gauss-Codazzi equations for  $M$  and  $S(TM)$  such that

$$\begin{aligned} \bar{R}(X, Y)Z = & R(X, Y)Z + B(X, Z)A_N Y - B(Y, Z)A_N X \\ & + \{(\nabla_X B)(Y, Z) - (\nabla_Y B)(X, Z) + \tau(X)B(Y, Z) \\ & - \tau(Y)B(X, Z) + B(T(X, Y), Z)\}N, \end{aligned} \tag{2.10}$$

$$\begin{aligned} \bar{R}(X, Y)N = & -\nabla_X(A_N Y) + \nabla_Y(A_N X) + A_N[X, Y] + \tau(X)A_N Y - \tau(Y)A_N X \\ & + \{B(Y, A_N X) - B(X, A_N Y) + 2d\tau(X, Y)\}N, \end{aligned} \tag{2.11}$$

$$\begin{aligned} \bar{R}(X, Y)PZ = & R^*(X, Y)PZ + C(X, PZ)A_\xi^* Y - C(Y, PZ)A_\xi^* X + \{(\nabla_X C)(Y, PZ) - (\nabla_Y C)(X, PZ) \\ & + \sigma(X)C(Y, PZ) - \sigma(Y)C(X, PZ) + C(T(X, Y), PZ)\}\xi \end{aligned} \tag{2.12}$$

$$\begin{aligned} R(X, Y)\xi = & -\nabla_X^*(A_\xi^* Y) + \nabla_Y^*(A_\xi^* X) + A_\xi^*[X, Y] - \sigma(X)A_\xi^* Y + \sigma(Y)A_\xi^* X \\ & + \{C(Y, A_\xi^* X) - C(X, A_\xi^* Y) - 2d\sigma(X, Y)\}\xi. \end{aligned} \tag{2.13}$$

### QUARTER-SYMMETRIC METRIC CONNECTIONS

Let  $(\bar{M}, \bar{g}, J)$  be an indefinite almost hyperbolic Hermitian manifold with a quarter symmetric metric connection  $\bar{\nabla}$ . Using (1.1), (2.1) and (2.7), we obtain

$$(\nabla_X g)(Y, Z) = B(X, Y)\eta(Z) + B(X, Z)\eta(Y), \tag{3.1}$$

$$T(X, Y) = \pi(Y)FX + \pi(X)FY; \tag{3.2}$$

$$B(X, Y) - B(Y, X) = \pi(Y)u(X) - \pi(X)u(Y), \tag{3.3}$$

where  $T$  is the torsion tensor with respect to  $\nabla$  and  $\eta$  is a 1-form such that

$$\eta(X) = \bar{g}(X, N).$$

Let  $a = \theta(N)$  and  $b = \theta(\xi)$ . As  $B(X, Y) = \bar{g}(\bar{\nabla}_X Y, \xi)$ , so  $B$  is independent of the choice

of S(TM) and satisfies

$$B(X, \xi) = 0, \quad B(\xi, X) = -bu(X). \quad \dots (3.4)$$

Local second fundamental forms are related to their shape operators by

$$B(X, Y) = g(A_{\xi}^* X, Y), \quad \bar{g}(A_{\xi}^* X, N) = 0, \quad \dots (3.5)$$

$$C(X, PY) = g(A_N X, PY), \quad \bar{g}(A_N X, N) = 0. \quad \dots (3.6)$$

Applying  $\bar{\nabla}_X$  to  $g(N, \xi)$  and using (2.2), (2.4) and  $B(X, \xi) = 0$ , we get  $\tau = \sigma$  and

$$\bar{\nabla}_X \xi = -A_{\xi}^* X - \tau(X)\xi. \quad \dots (3.7)$$

Taking  $X = \xi$  to (3.5) and using  $B(\xi, X) = -bu(X)$  and S(TM) is non-degenerate, so

$$A_{\xi}^* \xi = bV. \quad \dots (3.8)$$

Applying  $\bar{\nabla}_X$  to (2.6) and (2.7) and using (2.1), (2.2), (2.6), (2.7), (3.1), (3.6) and (3.7), we have

$$B(X, U) = C(X, V), \quad \dots (3.9)$$

$$\nabla_X U = F(A_N X) + \tau(X)U, \quad \dots (3.10)$$

$$\nabla_X V = F(A_{\xi}^* X) - \tau(X)V, \quad \dots (3.11)$$

$$(\nabla_X F)Y = u(Y)A_N X - B(X, Y)U. \quad \dots (3.12)$$

## RECURRENT HYPERSURFACES

Structure tensor field  $F$  of  $M$  is said to be recurrent [5] if there exists a 1-form  $\omega$  on TM such that

$$(\nabla_X F)Y = \omega(X)FY. \quad \dots (4.1)$$

A lightlike hypersurface  $M$  of an indefinite almost hyperbolic Hermitian manifold  $\bar{M}$  is called recurrent if it admits a recurrent structure tensor field  $F$ .

**Theorem :** Let  $M$  be a recurrent lightlike hypersurface of an indefinite almost hyperbolic Hermitian manifold  $M$  with a quarter-symmetric metric connection. Then

- (1)  $F$  is parallel with respect to the induced connection  $\nabla$  on  $M$ ,
- (2)  $D$  and  $J(\text{tr}(TM))$  are parallel distributions on  $M$ , and
- (3)  $M$  is locally a product manifold  $C_0 \oplus M^\#$ , where  $C_0$  is curve tangent to  $J(\text{tr}(TM))$  and  $M^\#$  is a leaf of the distribution  $D$ .

**Proof:** (1) From (4.1) and (3.12), we get

$$\omega(X)FY = u(Y)A_N X - B(X, Y)U. \quad \dots (4.2)$$

Replacing  $Y$  by  $\xi$  and using  $B(X, \xi) = 0$ , and the fact that  $F\xi = -V$ , we get  $\xi(X)V = 0$ . Taking the scalar product with  $U$ , we get

$\omega = 0$ . Which follows that  $\nabla_X F = 0$ . Thus  $F$  is parallel with respect to  $\nabla$ .

- (2) Taking scalar product with  $V$  to (4.2) with  $\omega = 0$ , we have

$$B(X, Y) = u(Y)u(A_N X).$$

Replacing  $Y$  by  $V$  and  $Y$  by  $FZ$ ,  $Z \in \Gamma(D_0)$  to above by turns, we get

$$B(X, V) = 0, \quad B(X, FZ) = 0 \quad \dots (4.3)$$

By equation (2.7), (3.1), (3.5) and (3.11), we have

$$\begin{aligned} g(\nabla_X \xi, V) &= -B(X, V), \quad g(\nabla_X V, V) = 0, \\ g(\nabla_X Z, V) &= B(X, FZ), \quad \forall Z \in \Gamma(D_0) \end{aligned} \quad \dots (4.4)$$

From (4.4) and (4.3), we have

$$\nabla_X Y \in T(D), \quad \forall X \in \Gamma(TM); \quad \forall Y \in \Gamma(D).$$

Therefore  $D$  is a parallel distribution on  $M$ .

Taking  $Y = U$  to (4.2), we have

$$A_N X = B(X, U)U. \quad \dots (4.5)$$

Applying  $F$  to (4.5), we have  $F(A_N X) = 0$ . ... (4.6)

From (4, 6) and (3.10), we have

$$\nabla_X U = \tau(X)U. \quad \dots (4.7)$$

Hence  $J(\text{tr}(TM))$  is also a parallel distribution on  $M$ .

(3) As  $D$  and  $J(\text{tr}(TM))$  are parallel distributions and satisfied (2.5), by the decomposition theorem [1],  $M$  is locally a product manifold  $C_0 \oplus M^\#$ , where  $C_0$  is a null curve tangent to  $J(\text{tr}(TM))$  and  $M^\#$  is a leaf of  $D$ .

### INDEFINITE COMPLEX SPACE FORMS

An indefinite complex space form  $\bar{M}(c)$  is a connected indefinite almost hyperbolic Hermitian manifold of constant holomorphic sectional curvature  $c$  such that

$$\bar{R}(\bar{X}, \bar{Y})\bar{Z} = \frac{c}{4} \{ \bar{g}(\bar{Y}, \bar{Z})\bar{X} - \bar{g}(\bar{X}, \bar{Z})\bar{Y} + \bar{g}(\bar{J}\bar{Y}, \bar{Z})\bar{J}\bar{X} - \bar{g}(\bar{J}\bar{X}, \bar{Z})\bar{J}\bar{Y} + 2\bar{g}(\bar{X}, \bar{J}\bar{Y})\bar{J}\bar{Z} \} \quad \dots (5.1)$$

Now comparing the tangential and transversal components of the two equations (2.10) and (5.1), and using (2.7) and (3.2), we have

$$R(X, Y)Z = B(Y, Z)A_N X - B(X, Z)A_N Y \quad \dots (5.2)$$

$$\begin{aligned} &+ \frac{1}{4} \{ g(Y, Z)X - g(X, Z)Y + \bar{g}(JY, Z)FX \\ &- \bar{g}(JX, Z)FY + 2\bar{g}(X, JY)FZ \} \end{aligned}$$

$$\begin{aligned} &(\nabla_X B)(Y, Z) - (\nabla_Y B)(X, Z) + \tau(X)B(Y, Z) - \tau(Y)B(X, Z) \\ &- \pi(X)B(FY, Z) + \pi(Y)B(FX, Z)) \\ &= \frac{c}{4} \{ u(X)g(FY, Z) - u(Y)g(FX, Z) + 2u(Z)\bar{g}(X, JY) \}. \end{aligned} \quad \dots (5.3)$$

Taking the scalar product with  $N$  to (2.12) and substituting (5.2) into the resulting equation and using (2.7), (3.2) and  $\bar{g}(A_N X, N) = 0$ , we have

$$\begin{aligned} &(\nabla_X C)(Y, PZ) - (\nabla_Y C)(X, PZ) - \tau(X)C(Y, PZ) + \tau(Y)C(X, PZ) \\ &- \pi(X)C(FY, PZ) + \pi(Y)C(FX, PZ)) \\ &= \frac{c}{4} \{ \eta(X)g(Y, PZ) - \eta(Y)g(X, PZ) + \nu(X)g(FY, PZ) - \nu(Y)g(FX, PZ) \} + 2\nu(PZ) \end{aligned} \quad \dots (5.4)$$

$$\bar{g}(X, JY).$$

**Theorem :** Let  $M$  be a recurrent lightlike hypersurface of an indefinite complex space form  $M(c)$  with a quarter-symmetric metric connection. Then  $\bar{M}(c)$  is flat, i.e.,  $c = 0$ , and the 1-form  $\tau$  is closed on  $M$ , i.e.,  $d\tau = 0$ .

**Proof:** Taking the scalar product with  $U$  to (4.5) and using (3.6), we have

$$C(X, U) = 0. \quad \dots (5.5)$$

Applying  $rY$  to this equation and using (4.7), we get

$$(\nabla_X C)(Y, U) = 0. \quad \dots (5.6)$$

Replacing  $PZ$  by  $U$  to (5.4) and using (5.5) with (5.6), we have

$$\frac{c}{2} \{ \nu(Y)\eta(X) - \nu(X)\eta(Y) \} = 0. \quad \dots (5.7)$$

Replacing  $X$  by  $\xi$  and  $Y$  by  $V$  and using

$$B(\xi, X) = -bu(X), \text{ we have } c = 0.$$

Putting (4.5) into (5.2) with  $c = 0$ , we have

$$R(X, Y)U = 0. \quad \dots (5.8)$$

By (4, 7), we have  $R(X, Y)U = 2d\tau(X, Y)U$ . ... (5.9)

By (5, 8) and (5, 9), we have  $d\tau = 0$ .

## REFERENCES

- [1] G. de Rham: Sur la reductibilit d'un espace de Riemannian, *Comm. Math. Helv.*, 26 (1952), 328-344.
- [2] K.L. Duggal and A. Bejancu: *Lightlike Submanifolds of Semi-Riemannian Manifolds and Applications*, Kluwer Acad. Publishers, Dordrecht, 1996.
- [3] D.H. Jin: Screen conformal lightlike real hypersurfaces of an indefinite complex space form, *Bull. Korean Math. Soc.*, 47 (2010), no. 2, 341-353.
- [4] D.H. Jin: Lightlike hypersurfaces of an indefinite Kaehler manifold with a quarter-symmetric metric connection, *Bull. Korean Math. Soc.*, 52 (2015), no. 1, 201-213.
- [5] D.H. Jin: Special lightlike hypersurfaces of indefinite Kaehler manifolds, accepted in *Filomat*, 2014.
- [6] K. Yano and T. Imai: Quarter-symmetric metric connection and their curvature tensors, *Tensor, N.S.*, 38 (1982).
- [7] Sushil Shukla: Real hypersurfaces of an almost hyperbolic Hermitian manifold. *Tamkang Journal of Mathematics*, v. 41, n. 1, p. 71-83, mar. 2010.

# Big Data and IOT its Current Trends and Technology

YADUVIR SINGH<sup>1</sup>, SARVACHAN VERMA<sup>2</sup> AND PRADEEP

## Abstract

*The main aim of this paper is to give you an idea about the current technologies and the trends that are going in the current market scenario for the implementation of the Big data aspects and Internet of things with its relevance in the real world. Big data is used in every field is a backbone of the Information and communication technology. In this paper our focus is on the current technology that is going on the market with respect to the Big Data and IOT.*

**Keywords:** *Sensor; Biochip Transponder; Operational Technology and Petabytes*

## INTRODUCTION

Big Data is data whose scale, diversity, and complexity require new architecture, techniques, algorithms, and analytics to manage it and extract value and hidden knowledge from it.

This term consists of 3 V's Volume(Scale of data),Variety,Velocity(Analysis of Streaming data) and one more term Veracity is included that completes the Big Data.

The information in digital sensors, communications, computation, and storage has created huge collections of data, capturing information of value to business, science, government, and society. For example, different search engine companies such as , Yahoo, Google and Microsoft have created an entirely new business by capturing the information freely available on the World Wide Web and providing it to people in useful ways. These companies collect peta bytes of data every day and continually add new services such as satellite images, driving directions, and image retrieval. The societal benefits of these services are immeasurable, having transformed how people find and make use of information on a daily basis.

Internet of Things: The Internet of Things (IoT) is a system of interrelated computing devices, mechanical and digital machines, objects, animals or people that are provided with identifiers and the ability to transfer data over a network without requiring human-to-human or human-to-computer interaction. A thing, in the Internet of Things, can be a person with a heart monitor implant, a farm animal with a biochip transponder, an automobile that has built-in sensors to alert the driver when tire pressure is low -- or any other natural or man-made object that can be assigned an IP address and provided with the ability to transfer data over a network.

---

<sup>1</sup> Department of Computer Science and Engineering and Applied Science

<sup>2</sup> Mangalmay Institute of Engineering and Technology, Greater Noida



IoT has evolved from the convergence of wireless technologies, micro-electromechanical systems (MEMS), micro services and the internet. The convergence has helped tear down the silo walls between operational technologies (OT) and information technology (IT), allowing unstructured machine-generated data to be analyzed for insights that will drive improvements.

The internet is having a huge and huge amount of data almost about petabytes of data available on the internet and this huge amount is generated by human being by pressing a button or scanning a bar code. The major problem with the collection of data is that the people are having a limited accuracy and attention during data capturing.

### **Big-Data Technology: Sense, Collect, Store, and Analyze**

The rising importance of big-data computing stems from advances in many different technologies:

**Sensors:** Digital data are being generated by many different sources, including digital imagers (telescopes, video cameras, MRI machines), chemical and biological sensors (microarrays, environmental monitors), and even the millions of individuals and organizations generating web pages.

**Computer networks:** Data from the many different sources can be collected into massive data sets via localized sensor networks, as well as the Internet.

**Data storage:** Advances in magnetic disk technology have dramatically decreased the cost of storing data. For example, a one-terabyte disk drive, holding one trillion bytes of data, costs around \$100. As a reference, it is estimated that if all of the text in all of the books in the Library of Congress could be converted to digital form, it would add up to only around 20 terabytes.

**Cluster computer systems:** A new form of computer systems, consisting of thousands of “nodes,” each having several processors and disks, connected by high-speed local-area networks, has become the chosen hardware configuration for data-intensive computing systems. These clusters provide both the storage capacity for large data sets, and the computing power to organize the data, to analyze it, and to respond to queries about the data from remote users. Compared with traditional high-performance computing (e.g., supercomputers), where the focus is on maximizing the raw computing power of a system, cluster computers are designed to maximize the reliability and efficiency with which they can manage and analyze very large data sets. The “trick” is in the software algorithms – cluster computer systems are composed of huge numbers of cheap commodity hardware parts, with scalability, reliability, and programmability achieved by new software paradigms.

**Facilities of Cloud Computing:** The rise of large data centers and cluster computers has created a new business model, where businesses and individuals can *rent* storage and computing capacity, rather than making the large capital investments needed to construct and provision large-scale computer installations. For example, Amazon Web Services (AWS) provides both network-accessible storage priced by the gigabyte-month and computing cycles priced by the CPU-hour. Just as few organizations operate their own power plants, we can foresee an era where data storage and computing become utilities that are ubiquitously available.

**Data analysis algorithms:** The enormous volumes of data require automated or semi-automated analysis – techniques to detect patterns, identify anomalies, and extract knowledge. Again, the “trick” is in the software algorithms - new forms of computation, combining statistical analysis, optimization, and artificial intelligence, are able to construct statistical models from large collections of data and to infer how the system should respond to new data. For example, Netflix uses machine learning in its recommendation system, predicting the interests of a customer by comparing her movie viewing history to a statistical model generated from the collective viewing habits of millions of other customers.

### ***Technology and Application Challenges***

Much of the technology required for big-data computing is developing at a satisfactory rate due to market forces and technological evolution. For example, disk drive capacity is increasing and prices are dropping due to the ongoing progress of magnetic storage technology and the large economies of scale provided by both personal computers and large data centers. Other aspects require more focused attention, including:

**High-speed networking:** Although one terabyte can be stored on disk for just \$100, transferring that much data requires an hour or more within a cluster and roughly a day over a typical “high-speed” Internet connection. (Curiously, the most practical method for transferring bulk data from one site to another is to ship a disk drive via Federal Express.) These bandwidth limitations increase the challenge of making efficient use of the computing and storage resources in a cluster. They also limit the ability to link geographically dispersed clusters and to transfer data between a cluster and an end user. This disparity between the amount of data that is practical to store, vs. the amount that is practical to communicate will continue to increase. We need a “Moore’s Law” technology for networking, where declining costs for networking infrastructure combine with increasing bandwidth.

**Cluster computer programming:** Programming large-scale, distributed computer systems is a longstanding challenge that becomes essential to process very large data sets in reasonable amounts of time. The software must distribute the data and computation across the nodes in a cluster, and detect and remediate the inevitable hardware and software errors that occur in systems of this scale. Major innovations have been made in methods to organize and program such systems, including the MapReduce programming framework introduced by Google. Much more powerful and general techniques must be developed to fully realize the power of big-data computing across multiple domains.

**Security and privacy:** Data sets consisting of so much, possibly sensitive data, and the tools to extract and make use of this information give rise to many possibilities for unauthorized access and use. Much of our preservation of privacy in society relies on current inefficiencies. For example, people are monitored by video cameras in many locations – ATMs, convenience stores, airport security lines, and urban intersections. Once these sources are networked together, and sophisticated computing technology makes it possible to correlate and analyze these data streams, the prospect for abuse becomes significant. In addition, cloud facilities become a cost-effective platform for malicious agents, e.g.,

to launch a botnet or to apply massive parallelism to break a cryptosystem. Along with developing this technology to enable useful capabilities, we must create safeguards to prevent abuse.

### **IOT AND ITS APPLICATIONS**

IOT and its applications in analytics can help companies to understand the disposal of data with an eye towards reducing costs for the maintenance, avoiding equipment failures and in all improving the business. In spite of this IOT can be used for the home appliances and medical lifesaving devices.

### **CONCLUSION**

In this paper our focus is on the basic technology trends and fundamental aspects of IOT and Big Data. This paper gives you an idea about the approach of the IOT and BigData which can be applied in every field whichever we are think of. The future scope of this paper is not limited to the contents specified in this paper but it is beyond the expectation of the technology.

### **REFERENCES**

- [1] <https://www.sas.com> › Home › SAS Insights › Big Data Insights
- [2] <https://www.ibm.com/big-data/us/en>
- [3] <https://www.sap.com/solution/big-data.html>
- [4] <https://bigdatauniversity.com/courses>
- [5] <https://www.simplilearn.com/big-data-applications-in-industries-article>
- [6] <https://www.analyticsvidhya.com> › Big data
- [7] <https://www.sap.com/solution/internet-of-things.html>
- [8] [www.happiestminds.com/Insights/internet-of-things](http://www.happiestminds.com/Insights/internet-of-things)
- [9] [www.cisco.com/c/en\\_in/solutions/internet-of-things/overview.html](http://www.cisco.com/c/en_in/solutions/internet-of-things/overview.html)
- [10] <https://www.microsoft.com/en-in/cloud-platform/internet-of-things>
- [11] [www.sas.com](http://www.sas.com) › SAS Insights › Big Data
- [12] [www.ibmbigdatahub.com/technology/internet-of-things](http://www.ibmbigdatahub.com/technology/internet-of-things)

# Mining and Identification of Human Behavioral Patterns using Scalable Algorithms

M. CHANDRA PRABHA<sup>1</sup>

## Abstract

*In traditional data analysis, systems are usually operated in a remote system. This is due to lack of scalability originating from software and hardware restrictions on mobile or wearable devices. In this paper, a set of scalable algorithms are used to identify patterns of human daily behaviors. These patterns are collected from Multivariate Temporal Data that have to be extracted from any smart phones. From these data's, frequent behavioral patterns are identified with a temporal granularity. This paper also demonstrates an approach on two real data sets and shows that the pattern identification algorithms are scalable. One is a human centric life-logging datasets can be created using real world settings and the other is device analyzer hardware centric, largest real world dataset can be created from android phones. This dataset demonstrate the scalable algorithms versatility and in dependency from the underlying data. Also it includes multivariate time stamped data. Temporal granularity algorithm gives flexibility in temporal analysis ie, dynamic human behavior. These identified patterns are used to help the end users and third parties those who are using these information provided by these services. By analyzing these data's, privacy can be achieved and leads to network cost reduction. Moreover, converting the raw timestamps to temporal granularities increase the accuracy of the Frequent Behavioral Pattern identification and these findings assist the system in identifying the appropriate run time and sensor impact of the behavioral pattern identification.*

---

<sup>1</sup> Assistant Professor/CSE Galgotia College of Engineering and Technology



**SECTION 4**

**HRM - The Road Ahead**



# Developing a Stakeholder Communication Strategy: The Case of Indian Railways and Swachh Campaign

RANJAN KUMAR<sup>1</sup>

## Abstract

*Starting in Oct, 2014 following the launch of Swachh Bharat Abhiyan by Prime Minister Modi, Indian Railways initiated the 'Swachh Rail Swachh Bharat Mission' to achieve the vision of 'Clean India' by 2019, the 150<sup>th</sup> birth anniversary of Mahatma Gandhi. Based on inputs from a pan-India survey assessing 407 railway stations on various cleanliness metrics, 18 stations were chosen for a performance improvement pilot project. Since cleanliness at railway stations requires active collaboration and participation from diverse stakeholders – passengers, vending stall owners, hawkers, porters, railway officials and cleaning staff, taxi/auto stand drivers etc. – Indian Railways was faced with the challenge of aligning them to a shared goal and achieving lasting behavioural change.*

*This paper documents the transformational journey underway at 18 of the dirtiest railway stations across India, in planning and implementing the 'Swachh Rail Swachh Bharat Mission'. Taking a consulting case approach, the paper explores how classical persuasive communication theories were used to develop a conceptual framework to plan, design and implement a multi-pronged stakeholder communication strategy. Further, with the benefit of hindsight, given the access to post-implementation stakeholder feedback on various cleanliness parameters at these railway stations, the paper convincingly establishes the relevance and real-world applicability of this framework in persuading and aligning stakeholders and achieving behavioural change.*

**Keywords:** *Persuasive Communication, Stakeholder Communication Strategy, Environmental Sustainability, Swachh Bharat Mission, Indian Railways*

## BACKGROUND AND CONTEXT

Indian Railways is the third largest rail network globally with a 66000 km route covering more than 8000 stations. Starting in Oct, 2014 following the launch of Swachh Bharat Abhiyan by Prime Minister Modi, Indian Railways initiated its 'Swachh Rail Swachh Bharat Mission' to achieve the vision of 'Clean India' by 2019, the 150<sup>th</sup> birth anniversary of Mahatma Gandhi. Subsequently, to understand the existing situation on the ground and develop a comprehensive plan, it commissioned a pan-India survey to the market research agency, TNS India Pvt Ltd involving 407 railway stations across 16 zones. The survey was

<sup>1</sup> Indian Institute of Management, Lucknow, Noida Campus, Uttar Pradesh  
E-mail: ranjan.kumar@iiml.org



conducted through interviews with different stakeholders – passengers, porters, vendors and hawkers, and railway officials and cleaning staff-on various cleanliness indicators (refer to Appendix 1 for questionnaire), and identified the following most crucial impact areas of improvement:

- Absence of stench in the station premises
- Adequate availability of dustbins
- Garbage disposal
- Availability & condition of toilets and availability of water in toilets

Among the railway stations surveyed, 75 were categorized as ‘A1’ and 332 as ‘A’, depending on their revenue contribution, with the former generating INR 60 crore or more in earnings per annum. Surat and Rajkot, both in Gujarat, came out first and second respectively in category ‘A1’, whereas, Gandhidham (Gujarat), Vasco da Gama (Goa) and Jamnagar (Gujarat) were rated the cleanest among category ‘A’ railways stations (Business Standard, 2016). Further, among railway stations rated as ‘Fair’ (Level 3), ‘Average’ (Level 2) or ‘Below Average’ (Level 1), 18 were chosen for a pilot project, whose objective was to transform them on the cleanliness parameters within a year.

The target review deadline was set as 31<sup>st</sup> Jan, 2017.

**Table 1:** Eighteen Stations Chosen for Pilot Project

<i>Region</i>	<i>Circle</i>	<i>Station</i>	<i>Category</i>	<i>Performance Score</i>
North	Delhi	H.Nizamuddin	A1	Level 2
North	NCR	Ghaziabad	A	Level 1
North	Punjab +Himachal +J&K	Jalandharcantt	A	Level 1
North	Uttar Pradesh+ Uttaranchal	Lucknow jn	A1	Level 4
North	Haryana + Rajasthan	Jaipur	A1	Level 3
Central	Maharashtra + Chhattisgarh	Nagpur	A1	Level 2
Central	Madhya Pradesh	Ratlam	A	Level 1
East	Rest of Bengal+ North East	Guwahati	A1	Level 2
East	Bihar + Jharkhand+ Orissa + Vizag	Patna Jn	A1	Level 3
East	Kolkata	Howrah	A1	Level 2
South	Karnataka	Mangalore	A	Level 3
South	Chennai	Chennai Central	A1	Level 3
South	Tamil Nadu + Kerala	Ernakulum town	A	Level 2
South	Andhra Pradesh	Vijayawada	A1	Level 3
West	Pune	Pune	A1	Level 1
West	Mumbai + Navi Mumbai+ Thane	CST Mumbai	A1	Level 3
West	Gujarat + West Rajasthan	Ahmedabad	A1	Level 3
West	Rest of Maharashtra + Goa	Kolhapur	A	Level 2

The most crucial aspect of achieving this challenging goal was to design and implement an effective communication strategy targeting diverse stakeholders - passengers, porters, vendors and hawkers, and railway officials.

## **LITERATURE REVIEW**

Persuasion can be defined as “human communication that is designed to influence others by modifying their beliefs, values, or attitudes (Simons, 1976).” In their endeavour to understand and explain the underlying dynamics of persuasive communication, scholars and researchers have come up with various theories. Five of these- the Elaboration Likelihood Model (ELM), Social Judgment Theory (SJT), Symbolic Convergence Theory (SCT), Cognitive Dissonance Theory (CDT), and Narrative Paradigm (NP)- form the bedrock of classical theories on persuasion.

### **Elaboration Likelihood Model (ELM)**

Developed by Cacioppo and Petty (1986), ELM provides a general theory of attitude formation and change. Despite a plethora of theories and vast quantity of data that had emerged by the late 1970s in the field of persuasion, the quest for a consistent explanation of how the four key communication variables- source, message, recipient, and channel- led to attitude change still continued.

In this backdrop, the ELM sought to establish itself as a conceptual umbrella integrating the various theoretical orientations. Broadly, the theory is built on two key premises. Firstly, it concludes that there are two distinct routes to persuasion- Central or high elaboration and Peripheral or low elaboration; the former resulting from a careful and considered evaluation of information presented in support of the argument, and the latter from a simple cue that obviates any careful scrutiny of what was being advocated. The second premise is that two variables, Motivation and Ability, of the recipient to evaluate the information presented, determine the extent to which the person would indulge in “issue-relevant” thinking. The elaboration likelihood would be high in case of higher motivation and ability, leading to information processing by the Central route, whereas, in the converse scenario, Peripheral route would be chosen.

### **Social Judgment Theory (SJT)**

Introduced in 1961 by Sherif and Hovland, the Social Judgment Theory was an attempt by the two researchers to explain and understand the apparent contradictions in attitude change research. Specifically, these contradictions pertain to two areas: how different individuals can react differently to the same communication; and how perceptual process errors of assimilation and contrast can defeat the goal of persuasion. The theory illustrated how individuals tend to form their personal positions (stance) on specific issues by contrasting it with their existing attitude (anchors).

Further, SJT proposed to measure one’s attitude towards others’ views as an amalgam of three latitudes (ranges):

- Latitude of Acceptance: comprising ideas and opinions that a person considers reasonable and is willing to accept

- Latitude of Rejection: those that are objectionable in one's opinions and therefore, not acceptable
- Latitude of Non-commitment: comprising positions that are neither objectionable nor acceptable

### **Symbolic Convergence Theory (SCT)**

Developed by Bormann (1972), the Symbolic Convergence Theory emerged from a project that had started as a method of rhetorical criticism, to study communication that takes place in small groups. The theory is founded on what Bormann called Fantasy Theme Analysis, defined as "the creative and imaginative interpretation of events that fulfills a psychological or rhetorical need." He drew upon this to establish a cause-and-effect hypothesis, maintaining that "the sharing of group fantasies creates symbolic convergence."

Key concepts underlying the Fantasy Theme Analysis include:

- Fantasy theme: a shared symbolic meaning that represents a common experience and shapes it into knowledge
- Symbolic cue: a word, phrase, slogan, or gesture that acts as a trigger to remind the group of an already shared fantasy theme
- Fantasy type: a fantasy theme that is understood across a wide variety of rhetorical contexts to draw meaning from a future phenomena
- Saga: a well-known and often repeated story around a community or organization

The structural component of a fantasy theme is contained in a rhetorical vision, which is composed of five elements- dramatis personae or actors, plot line, scene or location, a sanctioning agent or legitimizing authority, and a master analogue within which the rhetorical vision resides. The SCT contends that by exercising the fantasy theme artistry skillfully through a shared rhetorical vision amongst the target group, persuasive communication approaches can be made more successful.

### **Cognitive Dissonance Theory (CDT)**

The cognitive dissonance theory, distilled from a set of studies conducted by Leon Festinger (1957), traces its roots to social psychology. There are three key propositions underlying the theory:

1. Cognitive dissonance arises because of inconsistencies between actions and beliefs. For instance, if someone indulges in drunken driving but believes that it is dangerous, this could lead to cognitive dissonance.
2. Once created, cognitive dissonance is psychologically uncomfortable enough to motivate people to seek consonance or consistency. Therefore, it has the potential to alter their attitude and behaviour.
3. In a state of dissonance, people are likely to respond in one of the three ways to achieve consonance. One, they may change their belief to be consistent with the dissonant message. Two, they may alter their behaviour to and align it with the dissonant message, thus removing dissonance. The third approach is to avoid information and situations that increase the dissonance. If at all exposure to such information is unavoidable, e.g. 'Smoking causes cancer' messages on a cigarette

pack, they may use dissonance-reduction strategies to regain equilibrium, by acquiring new information that challenges the dissonant message or reduces its importance, particularly so if the dissonance affects their self-esteem.

### **Narrative Paradigm (NP)**

Rooted into what can be considered the oldest form of communication, story-telling, Narrative Paradigm was developed as a persuasion theory by Walter Fisher (1984), who famously stated that “We are persuaded more by a good story than a good argument.” As compared to the rational world paradigm, the narrative paradigm is based on the following assumptions:

- People are essentially story tellers, instead of rational beings.
- Human beings make decisions on the basis of good reason, instead of on arguments alone.
- History, biography, culture, and character determine what we consider good reasons.
- Narrative rationality is determined by the coherence and fidelity of our stories, instead of by how much we know and how well we argue.
- We experience the world as filled with stories and we must choose among them.

Referring to his theory as a “metaparadigm”, Fisher stated that the narrative paradigm combined both the macroforms- philosophy, rhetoric, poetic etc.- and the microforms- myths, metaphors, arguments etc.- of discourse. In one of his later works, Fisher (1985) explained this lucidly through textual analysis by citing the exchange between Socrates and Callicles in Plato’s *Gorgias*.

A comprehensive analytical framework comprising six criteria (Littlejohn, 2003) can be applied to evaluate these communication theories:

- *Theoretical scope*: relying on the Principle of Generality, this refers to the premise that any explanation provided by a theory must be sufficiently general to cover a range of events beyond a single observation. Two types of generality exist- the first is in terms of coverage of a broad domain i.e. explaining a range of communication-related behaviours, and the second deals with a narrow range of events or phenomena, but is applicable to a large number of situations within those. Commenting on this, Stanley Deetz (1992) states that “Few theories are failures in regard to specific situations, and all theories ultimately fail if applied far enough outside of the specific conditions for which they were developed. Theories thus differ more in the size of their domains and the realistic nature of their parameters than in their correctness.”
- *Appropriateness*: this is reflected in a logical consistency between the underlying assumptions of a theory and the theory itself. For instance, if a communication theory is based on the assumption that human beings are purposeful and in charge of their individual actions, the theory itself then can’t lead to the claim of a predictable, uniform behaviour.
- *Heuristic value*: this attends to the question whether a theory is capable of generating new ideas for further research and additional theories? Theories which can do so are can be considered to have a high heuristic value.

- *Validity*: generally, this is understood as the truth value of a theory. More specifically, there are three inherent meanings (Brinberg et al, 1985) - Value or worth, Correspondence or fit i.e. concepts or relations identified by the theory can actually be observed or not, and Generalizability.
- *Parsimony or Occam's Razor*: this equates with logical simplicity, meaning amongst two theories which are equally valid, the one with the simpler logical explanation where a few core assumptions and premises lead to logical conclusions, is more parsimonious.
- *Openness*: acknowledging an inherent limitation of any theory, that it is situational instead of reproducing reality or the absolute truth, this criterion assesses if a theory allows for dialogue and is open to new possibilities.

Our assessment of the five classical theories in persuasive communication, based on six parameters (refer to Table 1) offers rich insights into their relative strengths and weaknesses, both from a theoretical and practical standpoint.

**Table 2:** Comparative Ratings\* on Evaluation Parameters

	<i>CDT</i>	<i>SJT</i>	<i>SCT</i>	<i>ELM</i>	<i>NP</i>
Theoretical Scope	H	M	H	H	H
Appropriateness	H	M	H	H	H
Heuristic Value	H	H	H	M	H
Validity	H	L	M	M	L
Parsimony	H	L	H	M	L
Openness	H	H	H	H	H

\*H High, M-Medium, L- Low

While, Cognitive Dissonance Theory emerges to be the most robust theory overall, based on the framework chosen for this analysis, at the other end of the spectrum, the Narrative Paradigm is positioned as the least compatible with the scientific enquiry methodology. This is not surprising, considering that Narrative Paradigm was conceptualized as an alternative to the scientific and rational paradigm, and to that extent, has made a unique contribution in understanding human communication and human nature. SJT, SCT, and ELM make strong propositions, backed by experiments and have been well researched and dissected over the years.

## RESEARCH OBJECTIVES AND APPROACH

The specific research objective is to assess the impact of implementing a multi-pronged stakeholder communication strategy, derived from five classical persuasive communication theories- the Elaboration Likelihood Model (ELM), Social Judgment Theory (SJT), Symbolic Convergence Theory (SCT), Cognitive Dissonance Theory (CDT), and Narrative Paradigm (NP) – by the Indian Railways in achieving Swachh Mission goals at the 18 railway stations chosen for the pilot project. The broader research objective is to develop a conceptual framework for stakeholder communication strategy formulation and

implementation in environmental and social sustainability contexts, which require aligning stakeholders from highly diverse backgrounds and agendas with a shared goal.

To address these research objectives, the paper has taken a case study - based approach comprising three key steps:

- Conducting literature review of classical persuasive communication theories, to identify key conceptual attributes of each, instrumental in developing a stakeholder communication framework
- Designing a stakeholder communication framework, by linking conceptual elements of various persuasive communication theories with action items to be implemented
- Measuring and reporting on the impact and outcomes of implementing the stakeholder communication framework designed earlier

**DEVELOPING THE STAKEHOLDER COMMUNICATION FRAMEWORK**

The five classical persuasive communication theories discussed in the earlier section were utilized to create a conceptual framework for designing and implementing a comprehensive stakeholder communication strategy for Indian Railways.

The aim of this communication strategy was to achieve perceptual and behavioural change in each stakeholder segment, thus ensuring they were participating in and contributing to the Swachh Mission, instead of just being passive observers or worse, being unintentionally complicit in making railway stations unhygienic and dirty.

**Table 3:** Conceptual Framework and Strategic Action Item

Conceptual Basis	Underlying Persuasion Theory	Stakeholder Communication Action Item
High elaboration processing route	Elaboration Likelihood Model (ELM)	Education and sensitization drives with porters, hawkers, passengers
Low elaboration processing route	Elaboration Likelihood Model (ELM)	Creating aesthetic wall murals and installing signages
Dissonance-reduction and removal	Cognitive Dissonance Theory (CDT)	<ul style="list-style-type: none"> <li>• Installation of bio-toilets</li> <li>• Installation of dustbins</li> <li>• Beautification of station premises</li> </ul>
Narrative rationality, combining macroforms and microforms of discourse	Narrative Paradigm (NP)	<ul style="list-style-type: none"> <li>• Street Plays (‘NukkadNataks) and cultural programs</li> <li>• Wall paintings and banner creation with Swachhta messages</li> <li>• Focused group discussion</li> <li>• Audio-visual aid based storytelling</li> </ul>
Fantasy theme to achieve group convergence	Symbolic Convergence Theory (SCT)	Cause-effect documentation in the form of case studies, booklets, audio video clips, to motivate specific stakeholder segments e.g. porters, hawkers, vending stall owners

Developing and pushing the stakeholders' Latitude of Acceptance to enable adoption of new beliefs and attitudes	Social Judgment Theory (SJT)	<ul style="list-style-type: none"> <li>• Periodic cleaning drives, involving stakeholders and cleaning staff, to provide visible evidence as a convincing mechanism for achieving behavioural shift</li> <li>• Incentivizing stakeholders like porters, vendors through Contests/prizes/ rewards/recognitions</li> </ul>
---	------------------------------	--

### IMPACT AND OUTCOME

Indian Railways implemented the recommended stakeholder communication strategy at the eighteen railway stations chosen for pilot project. All the stations reported improvement in overall feedback on cleanliness parameters, with ten out of eighteen moving two levels or higher in performance score within a year. Further, in an impressive turnaround, among the four railway stations, Ghaziabad, Jalandhar, Pune and Ratlam that were in Red zone, i.e. Level 1 in Jan 2016, two (Ghaziabad and Pune) had transformed into Green zone within a year, while the other two also showed improvement. (refer to Table 4).

**Table 4:** Post-Implementation Status at 18 Railway Stations

<i>Scale of 1-5, where 1 is 'Below Average', 2 is 'Average', 3 is 'Fair', 4 is 'Good' and 5 is 'Very Good'</i>	<i>Performance Score (Jan 2016)</i>	<i>Performance Score (Jan 2017)</i>
Ahmedabad	Level 3	Level 4
Chennai Central	Level 3	Level 4
CST Mumbai	Level 3	Level 4
Ernakulam Town	Level 2	Level 4
Ghaziabad	Level 1	Level 5
Guwahati	Level 2	Level 4
H. Nizamuddin	Level 2	Level 4
Howrah	Level 2	Level 4
Jaipur	Level 3	Level 4
JalandharCantt.	Level 1	Level 3
Kolhapur	Level 2	Level 4
Lucknow	Level 4	Level 5
Mangalore	Level 3	Level 4
Nagpur	Level 2	Level 4
Patna	Level 3	Level 4
Pune	Level 1	Level 4
Ratlam	Level 1	Level 3
Vijaywada	Level 3	Level 4

The overall positive trend is reinforced in feedback scores of the four most crucial cleanliness impact areas – availability of dustbins, condition of toilets, absence of stench, and garbage disposal- with most stations scoring 4 or higher on these (refer to Figure 1-6 below).

**Availability of Dustbins**

While the overall feedback score on this parameter was 4.1 (‘Good’ – ‘Very Good’ range), Ghaziabad and Lucknow scored 5, while Jalandhar Cantonment and Mangalore were the least performing stations, with a feedback score of 2.5 and 3.1, respectively but still higher than last year.

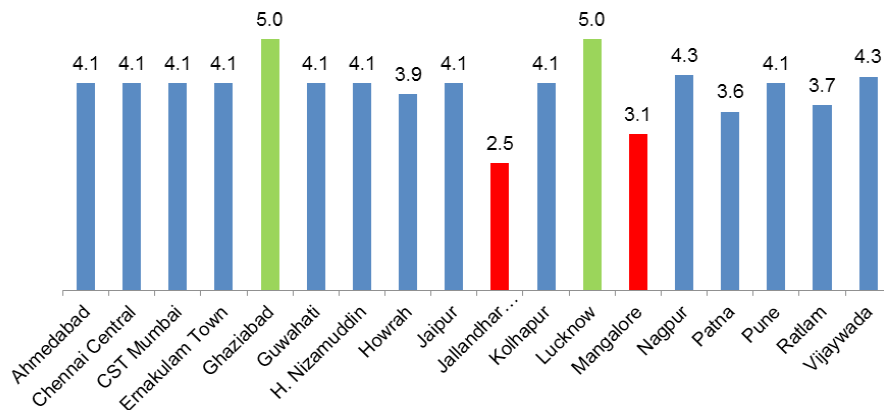

Figure 1: Adequate Availability of Dustbins

**Condition of Toilets**

Ghaziabad and Lucknow, with a score of 4.9/5, were rated as the two best stations on condition of toilets in general, while Jalandhar Cantonment, Mangalore, Nagpur and Patna were the least performing stations with score in the range of 1.4 – 2.5. The overall average was a satisfactory 3.75.

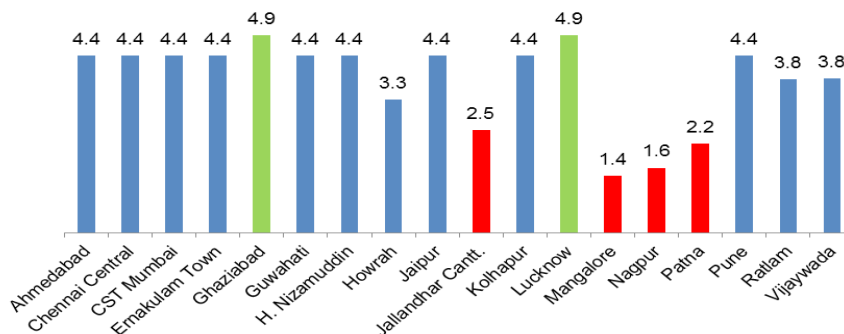

Figure 2: Condition of Toilets



### Absence of Stench

Ghaziabad and Lucknow, with a score of 4.9/5, were rated as the two best stations on this parameter, while Jalandhar Cantonment, Ratlam and Patna were the three least performing stations. The overall average was 3.7, although satisfactory but relatively lower compared to scores in most other parameters.

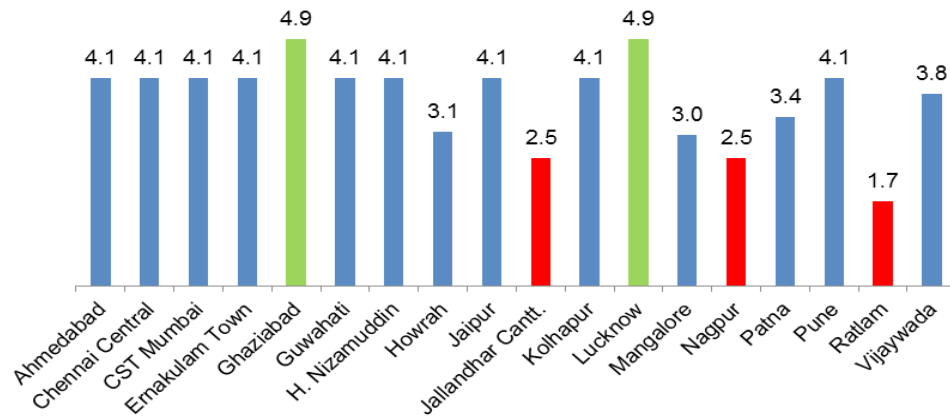

Figure 3: Absence of Stench

### Garbage Disposal

Ghaziabad and Lucknow, with a score of 4.7/5, were rated as the two best stations on this parameter, while Jalandhar Cantonment, Ratlam and Patna were the three least performing stations. The overall average was 3.8, relatively lower compared to scores in most other parameters and, H. Nizamuddin secured a feedback score of 4.1.

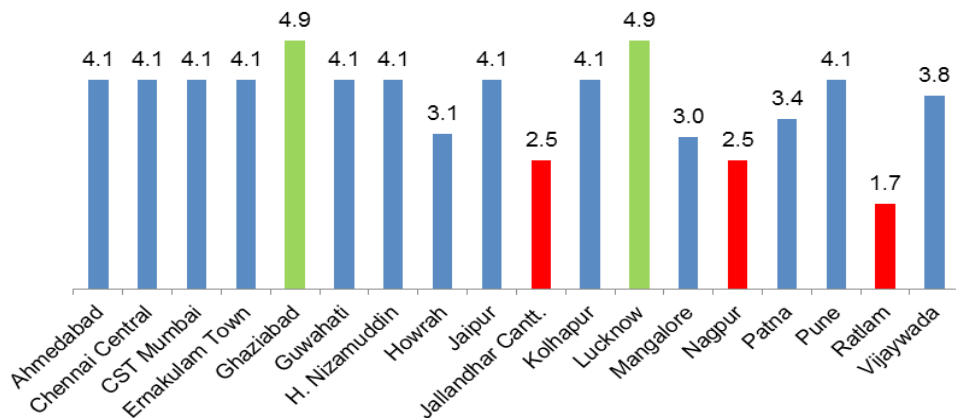

Figure 4: Garbage Disposal

**REFERENCES**

- [1] Bormann, E.G.,(1972), ‘Fantasy and rhetorical vision: The rhetorical criticism of social reality’, *Quarterly Journal of Speech*, Vol. 58, pp. 396-407.
- [2] Brinberg, David., McGrath, Joseph E., (1985), *Validity and the Research Process*, Sage Publications.
- [3] Business Standard, (2016), Published 18th March, Available at [http://www.business-standard.com/article/current-affairs/surat-rajkot-cleanest-railway-stations-in-india-survey-116031701011\\_1.html](http://www.business-standard.com/article/current-affairs/surat-rajkot-cleanest-railway-stations-in-india-survey-116031701011_1.html).
- [4] Cacioppo, John T., Petty, Richard E., (1986), The Elaboration Likelihood Model of Persuasion, *Advances in Experimental Social Psychology*, Vol. 19, pp. 123-161.
- [5] Deetz, Stanley A., (1992), *Democracy in an age of corporate colonization: Developments in communication and the politics of everyday life*, State University of New York Press.
- [6] Festinger, Leon, (1957). *A theory of cognitive dissonance*.Stanford University Press.
- [7] Fisher, Walter R., (1985), The Narrative Paradigm: An Elaboration, *Communication Monographs*, Vol. 52.
- [8] Fisher, Walter R. (1984). Narration as Human Communication Paradigm: The Case of Public Moral Argument, *Communication Monographs* Vol. 51, pp. 1–22.
- [9] Hovland, Carl I.; Sherif, Muzafer, (1961), *Social Judgment: Assimilation and contrast effects in communication and attitude change*. Yale University Press.
- [10] Littlejohn, Stephen W., (2003), *Theories of human communication*, Thomson Learning.
- [11] Simons, Herbert W., (1976), *Persuasion: Understanding, Practice, and Analysis*, Addison Wesley Publishing.

**APPENDIX 1**

Cleanliness Survey Questionnaire

- Q1** Tick on the applicable respondent type
  - 1. Passenger
  - 2. Indian Railway official
  - 3. Coolies/Licensed Porters
  - 4. Vendor (On platform)
- Q2.** How many times have you visited the station during last 1 year?
  - 1. 1 (Interview not to be conducted)
  - 2. 2 to 5
  - 3. 6 to 10
  - 4. More than 10
- Q3.** Name (For all Respondents)
- Q4.** Gender (Male/Female) (For all Respondents)
- Q5.** Address (For all Respondents)
- Q6.** E-Mail ID (For all Respondents)
- Q7.** Phone No. (For all Respondents)
- Q8.** PNR No./UTS

**Q9.** In which class are you travelling?

1. AC First Class
2. AC - 2 Tier
3. AC - 3 Tier
4. First Class
5. AC Chair Car
6. Sleeper
7. Second Sitting (general)

**Q10.** Please tell me your present age

1. 18-30 Years
2. 31-45 Years
3. 46-60 Years
4. 61 or more

**Q11.** What is your primary purpose of travel?

1. Business/Official/Conference
2. Sight seeing
3. Religious
4. Social Purpose (Wedding/Function/Meeting Family, Friends etc.)
5. Other

**Q12.** Please rate the following infrastructure and enabling provisions for proper upkeep/cleaning/sanitation on a scale of 1 to 5 where 5 is 'Very Good', 4 is 'Good', 3 is 'Fair', 2 is 'Average' and 1 is 'Below Average'.

1. Adequate availability of dustbins 1 2 3 4 5
2. Adequate availability of toilet in General 1 2 3 4 5
3. Adequate availability of toilets in pay and use 1 2 3 4 5
4. Adequate availability of toilets in Waiting rooms 1 2 3 4 5
5. Adequate availability of toilets in Circulating area 1 2 3 4 5
6. Condition of toilets in General 1 2 3 4 5
7. Condition of toilets in pay and use 1 2 3 4 5
8. Condition of toilets in Waiting rooms 1 2 3 4 5
9. Condition of toilets in circulating area 1 2 3 4 5
10. Availability of water in toilets and in other places for cleaning 1 2 3 4 5
11. Condition of flooring surface at platforms 1 2 3 4 5
12. Condition of flooring surface at waiting rooms 1 2 3 4 5
13. Condition of flooring surface at concourse 1 2 3 4 5
14. Condition of roof of platform shelter and storm water down pipelines to avoid leakage/flooding during rains 1 2 3 4 5
15. Condition of water booths and water coolers 1 2 3 4 5
16. Condition in circulating area including pavement, kerb walls, etc. 1 2 3 4 5
17. Adequate availability of signage boards prompting cleanliness/anti littering 1 2 3 4 5
18. Condition of vending stalls including arrangements for waste disposal 1 2 3 4 5
19. Proper system for collection and disposal of solid waste from trains 1 2 3 4 5
20. Proper system for collection and disposal of solid waste from stations 1 2 3 4 5

21. Proper dressing of Electric cables 1 2 3 4 5
22. Proper dressing of Telecom cables 1 2 3 4 5
- Q13.** Did you observe the use of appropriate uniform & personal protective equipment by cleaning staff? YES|NO
- Q14.** Did you observe the enforcement of anti-littering rules? YES|NO
- Q15.** Considering all factors how would you rate your overall satisfaction with the upkeep and cleaning on a scale of 1 to 5, where 5 is 'Very Good', 4 is 'Good', 3 is 'Fair', 2 is 'Average' and 1 is 'Below Average'.  
1 2 3 4 5
- Q16.** How would you rate your experience of visiting the railway station on following criteria on a scale of 1 to 5 where 5 is 'Very Good', 4 is 'Good', 3 is 'Fair', 2 is 'Average' and 1 is 'Below Average'.
  1. Absence of stench in the station premises 1 2 3 4 5
  2. Control of pest and rodent 1 2 3 4 5
  3. Control of flies and mosquitoes 1 2 3 4 5
  4. Functioning of cross and longitudinal waste water drains 1 2 3 4 5
  5. Stagnation of water in movement areas and non-movement areas 1 2 3 4 5
  6. Disposal/accumulation of garbage in dustbins and bulk disposal points 1 2 3 4 5
  7. Prompt disbursement of parcel/luggage from passenger movement areas 1 2 3 4 5
  8. Promptness in removal and disbursement of garbage 1 2 3 4 5
  9. Cleanliness and hygiene around vending stalls 1 2 3 4 5
  10. Cleanliness of platform areas 1 2 3 4 5
  11. Promptness in cleaning of extremes of dirtiness like nightsoil/vomit 1 2 3 4 5
  12. Presence/clearance of unwanted posters/notices 1 2 3 4 5
  13. Cleanliness of advertisement hoardings/signages 1 2 3 4 5
  14. Storage of scrap items & their prompt disposal 1 2 3 4 5
  15. Cleanliness of tracks between platforms 1 2 3 4 5
  16. Cleanliness of concourse and circulating area 1 2 3 4 5
  17. Cleanliness of foot over bridges 1 2 3 4 5
  18. Cleanliness of track area up to home signal beyond platform 1 2 3 4 5

# Strategies to Enhance Employability of Graduates from Technical Institutions

PRACHI AGARWAL<sup>1</sup> AND MINI AMIT ARRAWATIA<sup>2</sup>

## Abstract

*India is a relative very young country with majority of its work force falling in the category age limit of 20-40 yrs. Keeping in mind this age factor, it is easy to point out that this young crowd belongs to the Under Graduate/ Post Graduate and the working class. The Under Graduate students belong to a wide array of Technical and Non Technical courses. The charm for the Technical courses has been spreading like a jungle fire and the success rate of these needs to be questioned now. There are estimated 3,345 colleges in India offering various Technical courses and this number has increased manifold in the last decade. The adoption of Technical courses by the young crowd in India needs to be evaluated in the context of its success. There are about 1.5 million Technical Graduates passing out every year in India with only 3% having the skills to be employed in Software fields and 7% to be employed in the core engineering jobs. The numbers which are not eligible to be employed is indeed alarming and needs major consideration on. It's a collective effort from the Government, Technical heads and the Technical fraternity to ponder on this situation and take steps to increase the rate of employability.*

**Keywords:** *Employability, Higher Education Institutes, Technical Courses, Technical Graduates*

## INTRODUCTION

Employability refers to the possession of all the requisite skills, knowledge, attitude, and aptitude in a Graduate to make him/her Industry ready. It also refers to making him ready for the live jobs as soon as he/she hits the floor for working after department in the concerned department. The probation period for the industry which was earlier 6 months is now shrinking to 3 months and the day is not far that this will indeed be 0 months.

The world economy is changing at a very dynamic pace. With the buzz words of Globalization, International Relations etc. it is very apt to say that we are living a Global Village. Technology has bridged the gap between people. Everything is available at a click of mouse and all the available apps on the smart phones are becoming smarter. This increased competition is witnessed by all the Industry sectors and Academics is not untouched with this. Higher education institutes are under immense pressure from the students, government, and parentetic to raise the level of Education to be able to sustain them in the market. It is indeed logical to say that the absorption of a Graduate in the

---

<sup>1</sup> Research Scholar, Jayothi Vidyapeeth Women's University  
E-mail: knagar2010@yahoo.com

<sup>2</sup> Associate Professfor, Jayothi Vidyapeeth Women's University  
E-mail: miniamitarrawatia05@gmail.com

Industry depends on many factors like Market Economy, available jobs, preference of getting into a paid job rather than being an entrepreneur and being a job creator. But vast research shows that various hard skills and soft skills are important determinant to be able to term as employable. These include the Technical expertise of the information about the job, the various KRAs', interpersonal skills, self motivation, Flexibility, creativity, adaptability, self-initiator etc.

With the raising of standards of various accreditation bodies like NBA, NAAC etc. the college deliverables are increasing manifolds. As pointed before the Globalization and Liberalization of the world economy has raised a desperate need to produce Quality and Quantity of Engineers. The young Engineers must be constantly taught to learn, unlearn and relearn the things in accordance with the changing circumstances of the Technical world. These Engineers must be taught to work in National as well as International TEAMS and deliver the requisite performance as demanded by the Industry.

## **THE KEY FINDINGS**

### **Strategies to Improve Technical Education**

The mammoth task lying in front of the Technical Institutions is to raise the yard stick and the quality of the young passing out Technocrats. The question is how to do that? The increasing number of Technical Institutes has raised an alarming number and India being one of the largest suppliers of Engineers, if the quality of them is not improved, we would soon be entering in an era of Unemployment Explosion and desolation from the International Industries. The Duckweed effect will soon leave us with plethora of things to ponder upon about unemployment. Much research and penetrance is going on this fact now and some of the suggested strategies are as follows. We divide these suggestions/strategies in 2 divisions namely Hard Skills and Soft or Generic Skills.

### ***HARD SKILLS***

These are the skills required to do a job. They can also be termed as Technical Skills. Some of the key strategies to improve this are as follows:

- **Early start of the Technical Projects:** All the Technical Institutions need to implement an early start of the projects so that the students gain knowledge from it. The more they do from their own hands, the more they will learn.[1]
- **Correct Career Advice:** The students must be counselled properly so that their inclination towards the Technology be specified and their efforts are inclined towards their likings.
- **Research driven curriculum-** The students must be given lot of DIY (Do it yourself) things. The more they will research upon the topic, the more they will feel inquisitive and learn things themselves.
- **Internships:** The industry exposure in the mid of their course is recommended. This will broaden their horizons of learning and they will understand that there is a lot of difference between the curriculum and the industry. This will help them increasing their own knowledge.

- **Part Time Employment:** The students must be encouraged to do part time work so that they develop hard working capabilities from the student life itself.[2]
- **International student exchange program:** Communication with International student's community through face to face interactions or social media is very important. While we strive to make our Engineers ready to face Global technocrats, it is very vital to make them equipt with the work style of International clientele.[2]
- **Community Service:** The students must be taught to give back to the society whatever they can. This will not only help them become better citizens but also better TEAM players.
- **Industry specific curriculum:** The Institution/University curriculum needs to be made very industry specific so that the students are been taught the latest course needed by the Industry experts. This will not only help the students get better employed but also help the industry to make them ready for live projects.[3]
- **Initiatives by the Government:** the Government must run specific course related programs so that the students might benefit from the same. They can be proctored keeping in mind Entrepreneurship Development, Campus Placement or Government Jobs.
- **Industry Academia Interaction:** It is very pertinent that the people from the Industry must come forward and take the academics in the new stage of development and boon.[4]

### ***SOFT SKILLS***

These are generic skills that might not deter a person to do a job but definitely helps a him/her to do it better. Vast researches says that these skills pertinent to do be successful now a days.

- **Communication and Interpersonal skills:** It is of vital importance that the passing out graduates are very comfortable in their communication. It is of prime importance that they must deliver their thoughts very clearly in any language they are comfortable in.
- **Initiators and Problem Solving attitude:** The Industry need people who have the capacity to take initiatives with the accepted risk of being failing at times. They must be taught to have go getter attitude. **Learn, Unlearn and Re learn-** With technology replacing the latest technology after every 6 months, it is of prime importance that the young engineers understand this. They must be flexible and adaptable to changes happening in their professional and personal surroundings.
- **Cultural Acceptance:** The youth must be taught to be patient and take acceptance of the other's culture very positively.
- **Analytical Skills:** They must be taught to analyze the situations and gain insight from every day cues.
- **Integrity, Honesty and Ethics:** The youth must today be taught to have these qualities. The Industry need people who are passionate, loyal and honest.

### Implementation of The Suggested Strategies

It is prevalent that any strategy/suggestion always comes to a dead end if the implementation is not a success. Same holds true for all the suggestions above. It is very important for the Institutes to design a curriculum which is purely focused on learning teaching learning process. The teaching pedagogy must be designed in order to make the students technically sound and clear their fundamentals. The tutorials, assignments, marking scheme, tests etc must be tactfully designed. The weightage given to experiments, labs, Industrial Trainings and other practical work must be progressed in a way that the students feel inclined in doing these tasks. The pedagogy must be such that the student must follow the teacher and not vice versa as against today's Academic era.

Weightage must be given to even the smallest detail. Be it naming the apparatus in the experiment, noting the readings, correct mathematical units etc. Co-curricular and Extra Curricular activities must be periodic to break the monotony of the students and bring in their leadership, TEAM building and problem solving techniques.

### CONCLUSION

The declining employability has been a grave issue with most of the world economies. Studies states that leading countries like Australia, Zimbabwe including India is facing this concern. Technical Institutes are set up with a vision to provide world level education. With the technology taking the giant steps it is very pertinent that the employability issue is addressed by the collective efforts of Institutes, Academicians, Government and students so that we do not enter in the era of Unemployment explosion.

### REFERENCES

- [1] S. R. Ganorkar, Anjana Tiwari, "Enhancing the Employability of Students' Passing from Technical Institutions", *Issues and Ideas in Education*, Vol. 1, No. 2 September 2013.
- [2] Shelley Kinash, "8 ways to enhance your students' graduate employability", report prepared for the office for Learning & Teaching Australian Government, <http://graduateemployability.com>, Jan 26, 2015.
- [3] Evelyn Chiyevu Garwe, "Holistic initiatives for enhancing graduate employability in Zimbabwe", *Research in Higher Education Journal*:
- [4] A. McKnight, "Labour market returns to undergraduate sandwich course programmes", *London School of Economics*, 2002.
- [5] Nunan, T., George, R. and McCausland, H. (2000), Implementing graduate skills at an Australian university.
- [6] Fallows, S. and Steven, C. (Eds), *Integrating Key Skills in Higher Education: Employability, Transferable Skills and Learning for Life*, Kogan Page, London, pp. 57-66.
- [7] AggarwalV., "Aspiring Minds National Employability Report-Engineers 2016", <http://www.aspiringminds.com/research-reports>, 2016.



# Differential Cross Sections Parameters of Alkali Atoms

RAVI SHANKER<sup>1</sup>, R.S UPADHYAY<sup>2</sup>, V.K. GOYAL<sup>3</sup> AND SACHIN SAXENA<sup>1</sup>

## Abstract

*We have carried out distorted wave (DW) calculations for electron impact  $3\ ^2S - 3\ ^2P$ ,  $4\ ^2S - 4\ ^2P$  and  $5\ ^2S - 5\ ^2P$  resonance excitation of sodium, potassium and rubidium atom at incident electron energies in the range 100-210 eV. Detailed results for different collision parameters are reported which include unresolved fine-structure differential cross sections for these transitions. Good agreement is found on comparison with the theoretical calculations at 100eV, 150eV, 200eV and 210eV incidence energies. And our calculation at 105eV, 155eV & 205eV incidence energies show good result.*

## INTRODUCTION

Electron excitation of alkali atoms have been extensively studied both theoretically and experimentally in various collision parameters [1,2]. From this point of view, the electron impact excitation of alkali atoms are considerable attention [2,3]. The study of relativistic effects of alkali atom at different transition would be most interesting.

For the differential cross sections (DCS) of electron excitation of the alkali atoms have been reported by Vuskovic et al [4] while Chen and Gallagher [5] and Zapesochnyi et al [6] and others review [7,8,9,10]. Much later [11,12] performed relativistic distorted wave (RDW) calculations and DWBA calculation for the DCS for the resonance transitions of many alkali atoms and compared their results with the experiment and each other. In this paper we take DWA method to study the electron excitation of alkali atoms for three different transition (for sodium  $3\ ^2S - 3\ ^2P$ , potassium  $4\ ^2S - 4\ ^2P$  and rubidium  $5\ ^2S - 5\ ^2P$ ) resonance transitions and report our extensive results for differential cross sections. However, presently we will show our results at 105eV, 155eV & 205 eV incidence energies and behavior of the curve show a good result for the same incident energies. We therefore, consider these excitations also in the present paper show good calculation for the DCS.

---

<sup>1</sup> Asst. Professor, Department of Physics, H.R Institute of Technology, Ghaziabad (UP)  
E-mail: ravi01shanker@gmail.com: sachinsania@yahoo.co.in

<sup>2</sup> Reader, Department of Physics, D.A.V .P.G Bulandshahar (UP)

<sup>3</sup> Reader, Department of Physics, Anoopshahar D.P.B.S.P.G Collage (UP)

### THEORETICAL CONSIDERATIONS

#### Distorted Wave Approximation (DWA) Theory

T-matrix can be written from an initial state ‘i’ to any final state ‘f’ (with magnetic sub state M) for electron impact excitation of an N-electron atom

$$T_f(M) = \langle \chi_f^- | V - U_f(\mathbf{r}_{N+1}) | \chi_i^+ \rangle \quad \dots(1)$$

where

$$\chi_{i(f)}^{+(-)} = A \phi_f(\mathbf{r}_1, \mathbf{r}_2, \dots, \mathbf{r}_N) F^{+(-)}(\mathbf{k}_{i(f)}, \mathbf{r}_{N+1}) S_{i(f)}(1, 2, \dots, N; N+1) \quad \dots (2)$$

$$V = -\frac{Z}{r_{N+1}} + \sum_{j=1}^N \frac{1}{|\mathbf{r}_j - \mathbf{r}_{N+1}|} \quad \dots (3)$$

A is antisymmetrization operator. Z is the nuclear charge of the target atom.  $S_{i(f)}(1, 2, \dots, N, N+1)$  is the initial (final) state spin function for the composite projectile electron and target atom system.  $\phi_{i(f)}$  is the bound state initial (final) wave function of the target atom.  $F^{+(-)}(\mathbf{k}_{i(f)}, \mathbf{r})$  is the projectile distorted wave in the initial (final) channel with wave vector  $\mathbf{k}_i(\mathbf{k}_f)$  and satisfies following equation

$$[\nabla_{N+1}^2 + k_{i(f)}^2 - \mathcal{U}_{i(f)}(\mathbf{r}_{N+1})] F^{+(-)}(\mathbf{k}_{i(f)}, \mathbf{r}_{N+1}) = 0 \quad \dots (4)$$

The distortion potential  $U_{i(f)}$  in the initial (final) channel is given by

$$U_{i(f)} = V_a^{\text{stat}} + V_{i(f)}^{\text{exch}} \quad (\text{with } a = i \text{ or } f) \quad \dots (5)$$

Here  $V_a^{\text{stat}} = \langle \phi_a | V | \phi_a \rangle$  is static potential. The exchange potential  $V_a^{\text{ex}}$  is taken to be the widely used form[13].

We expand the distorted waves  $F^+$  and  $F^-$  using the following general form of partial wave expansion

$$F^{+(-)}(\mathbf{k}, \mathbf{r}) = \frac{1}{\sqrt{k}} \sum_{\ell=0}^{\infty} (2\ell + 1) i^\ell e^{\pm i\delta_\ell} k^2 \frac{u_\ell^\pm(k, r)}{r} P_\ell(\hat{\mathbf{k}} \cdot \hat{\mathbf{r}}) \quad \dots (6)$$

Where  $\delta_\ell$  is the phase shift of the  $\ell$ th partial wave,  $P_\ell$  is the Legendre polynomial of order  $\ell$  and  $u_\ell^\pm(k, r)$  is radial part of the distorted wave. On substituting  $F^\pm$  as given above from equation (6) we get

$$\left[ \frac{d^2}{dr^2} + k^2 - \frac{\ell(\ell + 1)}{r^2} + 2U(r) \right] u_\ell(k, r) = 0 \quad \dots (7)$$

which is solved numerically subject to the following usual boundary conditions.

$$u_\ell(k, r) = 0 \quad \text{as } r \rightarrow 0 \quad \dots (8)$$

and

$$u_\ell(k, r) \underset{r \rightarrow \infty}{=} \frac{1}{\sqrt{k}} \sin\left[\mathbf{k} \cdot \mathbf{r} - \frac{1}{2} \ell \pi + \delta_\ell(k^2)\right] \quad \dots (9)$$

From eq.(1) the direct and exchange T-matrices are evaluated for the excitation of each magnetic state M of the final excited state. We obtain the T-matrices for the singlet (s) and triplet (t) modes separately. Further, the scattering amplitude for each magnetic sub state M of the final excited state is related to the T-matrix by

$$a_M^{s(t)} = -\frac{1}{2\pi} T_f^{s(t)}(M) \quad \dots (10)$$

The differential cross section (DCS) in the singlet (triplet) mode can therefore be expressed in terms of the scattering amplitude as

$$\sigma_M^{s(t)} = \frac{k_f}{k_i} \left| a_M^{s(t)} \right|^2 \quad \dots (11)$$

and the spin-averaged DCS as

$$\sigma_M = \frac{1}{4} \sigma_M^s + \frac{3}{4} \sigma_M^t \quad \dots (12)$$

Finally, the DCS summed over the different values of M is

$$\sigma = \sum_M \sigma_M \quad \dots (13)$$

In addition, the integrated cross sections after integrating over all scattering angles for different values of M are obtained in terms of the spin-averaged DCS by

$$Q_M = \int \sigma_M \, d\Omega \quad \dots (14)$$

## RESULTS AND DISCUSSION

Using the DWA method we calculate the DCS for sodium  $3^2S - 3^2P$ , potassium  $4^2S - 4^2P$  and rubidium  $5^2S - 5^2P$  excitations. Atomic target wave functions for the ground  $n^2S$  and the excited  $n^2P$  ( $n=3,4,5$ ) are obtained from the Hartree-Fock atomic structure code of Fischer [14]. These are also used to obtain the distortion potential for obtaining the distorted waves in eq.(4). The calculations are performed in the incident electron energy range from 100 to 210eV.

In figure 1 & 2, we present our DWA results of differential cross-sections for the individual  $3^2P$  &  $4^2P$  excitation of Na & K atoms respectively at 105eV, 155eV & 205 eV incident electron energies. These result show good behavior as results on slightly higher incident energies at 100eV, 150eV, 200eV & 210eV for DWA & RDW calculations [10].

In figure 3, we present our DWA results of differential cross-sections for the individual  $5^2P$  excitation of Rb atom. The result at 105eV, 155eV & 205 eV incident electron energies show good result. The comparison of DCS at different incident energies for DWA & RDW are behave good at 100eV, 150eV, 200eV & 210eV calculations [10,11].

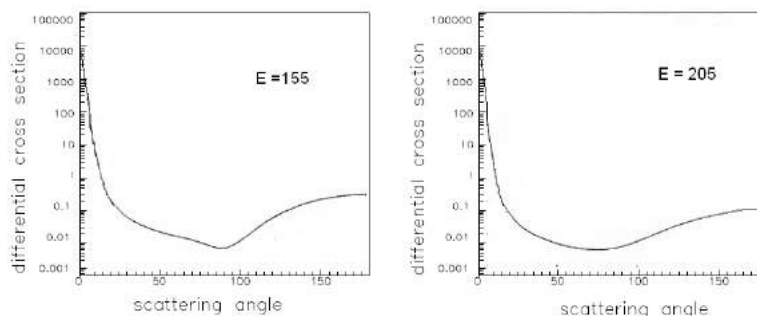

Figure 1. Differential cross sections in atomic units for the excitation of the  $3\ ^2P$ , state of Na by electron impact at 155 and 205 eV. — present DWA

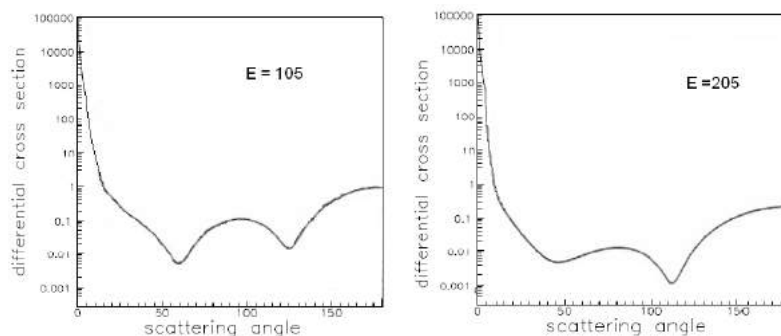

Figure 2. Differential cross sections in atomic units for the excitation of the  $4\ ^2P$ , state of K by electron impact at 105 and 205 eV. — present DWA

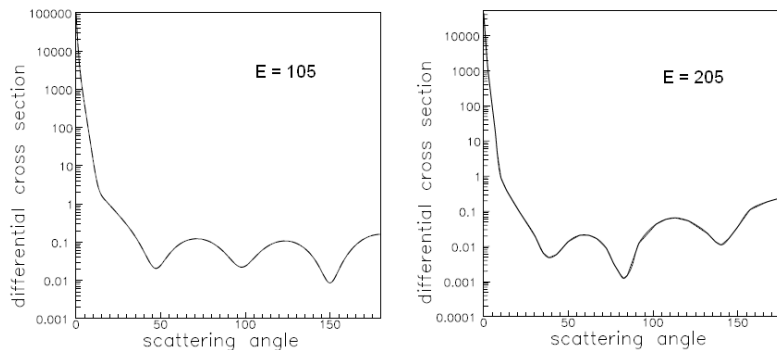

Figure 3. Differential cross sections in atomic units for the excitation of the  $5\ ^2P$ , state of Rb by electron impact at 105 and 205 eV. — present DWA

## CONCLUSIONS

In this paper we have presented our DWA calculations of the DCS parameter in detailed manner for the alkali atoms at different transitions atom. The nature of the curve show good behavior at different incident energies. The result of above and below of our incident energies show close agreement of the DWA and RDW calculations for the DCS and various

sensitive parameters suggest that the relativistic effect may not be very important here. Thus we feel confidence that our other results for DCS parameter reported here would be quite reliable and useful for the future comparison purposes.

## REFERENCES

- [1] N. Andersen, J.W. Gallagher, I.V. Hertel, Phys. Rep. 165, 1 (1988).
- [2] N. Andersen, K. Bartschat, J.T. Broad, I.V. Hertel, Phys. Rep. 279, 251 (1997).
- [3] N. Andersen, K. Bartschat, J. Phys. B 35, 4507 (2002)
- [4] L. Vuskovic, L. Maleki, S. Trajmar, J. Phys. B 17, 2519 (1984).
- [5] S.T. Chen, A.C. Gallagher, Phys. Rev. A 17, 551 (1978).
- [6] I.P. Zapesochnyi, E.N. Postoi, I.S. Aleksakhin, Sov. Phys. -JETP 41, 865(1976).
- [7] B.V. Hall, A.J. Murray, W.R. MacGillivray, M.C. Standage, I. Bray, Proc. Abstr. XXI ICPEAC (1999) p.190-SA050.
- [8] M.R. Went, M.L. Daniell, W.E. Guinea, K. Bartschat, B. Lohmann, W.R. MacGillivray, Proc. Abstr. XXIII ICPEAC (2000) Fr050
- [9] Bransden, B.H. and McDowell, M.R.C., Phys. Rep., 30C, 207 (1997).
- [10] Bray, I., Fursa, D. V. and McCarthy, I. E., Phys. Rev. A, 49, 2667 (1994).
- [11] V. Zeman, R.P. McEachran, A.D. Stauffer, Eur. Phys. J. D. 1, 129 (1998)
- [12] S. Saxena and R. Srivastava, Eur. Phys. J. D 30, 23 (2004).
- [13] J.B. Furness, I.E. McCarthy, J. Phys. B 6, 2280 (1973)
- [14] C. F. Fischer, Comput. Phys. Commun. 1, 151 (1969)

# Body Language in Business Negotiations

APEKSHA MISHRA<sup>1</sup>

## Abstract

*Human beings communicate through a variety of channels. Language is not the sole means by which humans exchange information. In conversation, we express our ideas and feelings not only with words but also through facial expressions, voice tones, and gestures. These non-verbal languages are called “Body Language”. It is just like our verbal language, is also a part of our culture. In business negotiations, body language plays a significant role in the communication. It is necessary to master the skills of using and reading body language. This article mainly discusses the art of body language in negotiation. It states its functions and importance in business negotiations, then explores how to use and understand body language in negotiations. Different people have different ways of making nonverbal communication. It shows the importance of knowing the specific signals that go together with a language. It finally emphasizes the necessity and importance of learning body language in non-verbal communication and business negotiations.*

**Keywords:** *Body Language, Negotiation, Different Culture, Different Ways*

## INTRODUCTION

Some studies show that up to 90 percent of communication is nonverbal. Though you might say one thing, your body movements may indicate something entirely different. All types of language that take place without words are defined as nonverbal language. Language that doesn't use words takes place all the time. When we converse with others we communicate by much more than words. By our expressions, gestures, eye movements and other body movements, we send messages to those around us. A smile and an outstretched hand show welcome; a frown is a sign of displeasure, nodding one's head means agreement—“Yes”, waving an outstretched hand with open palm is the gesture for “Goodbye”, leaning back in one's seat and yawning at a talk or lecture shows lack of interest, boredom. These are some of the expressions through which we can show the usage of nonverbal communication.

Many people may think that to have a successful negotiation, the negotiators must master the language skills of negotiation and bargaining, to some extent, they are right. But that is far more enough. In fact, many negotiators are not aware that they communicate nonverbally. Most nonverbal messages are involuntarily. Verbal language really play important role in negotiations, but it is not the only means by which negotiators exchange information. In negotiation, for example, negotiators express their ideas and feelings not

---

<sup>1</sup> Assistant Professor, Acropolis Institute of Technology & Research, Indore (M. P.)  
E-mail: lapekshamishra23@gmail.com

only with words, but also through facial expressions, eye contact, voice tones and gestures. Even clothing and grooming may send message of one kind or another to others. Some experts say only 30 percent of communication comes from talking. Your gestures and other nonverbal actions matter too. An old saying goes: “actions speak louder than words.” That’s true according to communication experts.

### **THE DEFINITION OF BODY LANGUAGE AND THE NECESSITY AND IMPORTANCE OF LEARNING BODY LANGUAGE IN NEGOTIATION**

We all instinctively give gestures and facial expressions which reveal our inner thoughts. It’s hardwired into our brains and stretches back to our earliest days in the cave when facial expressions and gestures were all we had to communicate with. Like music tracks on a CD these communication tools have been burned into our brains. Our body language becomes part of our conversation. It sends signals to another person about us. We should present ourselves with confidence and authority and practice good posture. Stand with our back straight, shoulders back, and our chin up. Our voice does not sound clear when our chin is dropped toward our chest. Keep our arms relaxed at our side and avoid clasping our hands behind our back or hugging our arms in front, portray calmness, avoid nervous gestures such as tapping our foot or jingling coins in our pocket or playing with a pen. Keep our hands off our face and never make unnecessary hand gestures. The way we walk and the way we talk all tell something about our social status. These gestures have come to be accepted in general as having the meanings mentioned. These gestures have come to be accepted in general as having the meanings mentioned, at least to Chinese and Americans.

#### **The Definition of Body Language**

As we mentioned earlier, it is impossible for us to stop communicating non-verbally. We all lean, point and look away. We move our hands to emphasize in our talk and technically it is called Haptics. We frown, smile, fold our arms, and move toward objects or people, then move away. How we stand, walk, eat, and gesture reveals much about our personality. It is called “body language”. It is an important media through which people communicate with each other. It refers to the patterns of facial expressions and gestures that people use to express their feelings in communication. “Body language” also defined as the nonverbal communication or the communicative functions of body, it is also called kinesics. It is part of the way in which we communicate. This “body language”, like our verbal language, is also a part of our culture. There are different ways through which we can do non-verbal communication like Oculistics, Chonemics, Proxemics, Appearance and accessories etc.

#### **The Necessity and Importance of Learning Body Language in Negotiation**

It is an extremely powerful tool which can improve our life in many ways. With patience, persistence, and practice we can use nonverbal behavioral patterns to more easily detect truth and lies, project a more confident, powerful presence, persuade, influence, and sell better, put people at ease, create a sense of trust, make friends. It is especially important in business negotiations. If you are only aware of a negotiator’s verbal message, you will

likely miss the major portion of the overall communication. Being aware of both nonverbal and verbal messages will give you an important edge. A negotiator must aware of the synchronization between verbal and Non-verbal communication.

Communication is more than verbal. Good negotiators must first be good communicators. Unfortunately, many negotiators think of communication only as oral or written verbal exchanges. But verbal exchanges account for only a fraction of the messages people send and receive. Research has shown that between 70 and 90 percent of the entire communication spectrum is nonverbal. Consequently, you should be aware of the different forms of nonverbal communication that you are likely to encounter during negotiation conferences.

## **THE CONCRETE TYPES AND APPLICATION OF THE BODY LANGUAGE IN NEGOTIATION**

### **Types of Body Language**

Body language or kinesics can be understood by recognizing the following six important aspects.

#### ***Distance between people conversing***

Watch an Arab and an Englishman in negotiation. The Arab, showing friendliness in the manner of his people, will stand close to the Englishman. The latter will move back, watching to the Englishman. The Arab will then move forward to be closer; the Englishman will keep moving backward. By the end of the negotiation, the two may be quite a distance from the negotiation; the two may be quite a distance from the place where they were originally standing!

Here, distance between the two is the key factor. Different people have different ideas about the proper distance between people conversing. According to studies, it seems there are four main distances in American social and business relations: intimate, personal, social, and public. Intimate distance ranges from direct physical contact to a distance of about 45 centimeters; this is for people's most private relations and activities, between man and wife, for example. Personal distance is about 45—80 centimeters and is most common when friends, acquaintances and relatives converse. Social distance may be anywhere from about 1.30 meters to 3 meters; people who work together, or people doing business, as well as most of those in conversation at social gatherings tend to keep a distance is farther than any of the above and is generally for speakers in public and for teachers in classrooms.

The important thing to keep in mind is that most English-speaking people do not like people to be too close. In negotiations being too far apart, of course, may be awkward, but being too close makes people uncomfortable, unless there is a reason, such as showing affection or encouraging intimacy. But that is another matter.

#### ***Physical appearance and physical contact***

Physical appearance conveys messages. It plays a very important role in creating first impression. You need to be aware of the effect that your physical appearance may have on



nonverbal communication. Awareness may permit you to build on your natural advantages. However, awareness of any natural disadvantage may be even more important.

Research has found that:

*Physical attractiveness affects the way you perceive yourself and the way other perceive you.*

Personal Dress: The importance of how we dress is highlighted by the cliché, “Dress for success.” Clothing has been found to affect perceptions of credibility, likeability, attractiveness, and dominance, but researchers agree that clothing has the most potent affect on credibility. Reason being the way we dress, we represent our company, our mentality, our culture and system. While dressing one more thing need to be kept in mind and i.e. accessories, most of the times it happens that people accessorize themselves to much which distracts the attention of the listeners and audiences.

Unfortunately, many otherwise good negotiators ignore the importance of personal dress during negotiations, and that ignorance negatively affects their ability to attain mutually satisfactory negotiation results.

In English-speaking countries, physical contact is generally avoided in conversation among ordinary friends or acquaintances. Merely touching someone may cause an unpleasant reaction. If one touches another person accidentally, he/she usually utters an apology such as “Sorry, Oh, I’m sorry, Excuse me.”

The matter of physical contact between members of the same sex in English-speaking countries is a delicate one. Once past childhood, the holding of hands, or walking with an arm around another’s shoulder is not considered proper. The implication is homosexuality, and homosexuality generally arouses strong social disapproval in these countries.

### ***Eye contact***

Eye contact is an important aspect of body language. One could draw up quite a list of “rules” about eye contact or technically known as Oculesics: to look or not to look; when to look and how long to look; who and who not to look at.

There are different formulas for the exchange of glances depending on where the meeting takes place. If you pass someone in the street you may eye the oncoming person till you are about eight feet apart, then you must look away as you pass. Before the eight-foot distance is reached, each will signal in which direction he will pass. This is done with a brief look in that direction. Each will veer slightly, and the passing is done smoothly.”

In conversations with people who know each other, however, American custom demands that there should be eye contact. This applies to both the speaker and the listener. For either one not to look at the other person could imply a number of things, among which are fear, contempt, uneasiness, guilt, indifference, even in public speaking there should be plenty of eye contact. For a speaker to “burry his nose in his manuscript”, to read a speech instead of looking at and talking to his audience, as some Chinese speakers are in the habit of doing, would be regarded as inconsiderate and disrespectful.

In conversation, a person shows that he is listening by looking at the other person’s eyes or face. If the other person is speaking at some length, the listener will occasionally

make sounds like “Hmm”, “Ummm”, or nod his head to indicate his attention. If he agrees with the speaker, he may nod or smile. If he disagrees or has some reservations, he may slant his head to one side, raise an eyebrow, and have a quizzical look.

Staring at people or holding a glance too long is considered improper in English-speaking countries. Even when the look may be one of appreciation—as of beauty—it may make people uneasy and embarrassed. Many Americans traveling abroad find the stares of the local people irritating. They become extremely self-conscious and often end up quite indignant about the “rudeness” of the people there, not realizing that the practice may be quite common in the country and may be nothing more than curiosity. Many English-speaking people in China have heard to complain about this.

The difference in interpreting a simple eye gesture was a lesson in cultural diversity that we would not easily forget. For example, Chinese avoid long direct eye contact to show politeness, or respect, or obedience, while North Americans see eye contact as a sign of honesty and a lack of eye contact or shift eyes as a sign of untruthfulness. Though speaking the same language, the British, unlike the Americans, believe that looking someone directly on the eye to be a mark of rudeness until a more familiar relationship is established. An American businesswoman told a story that they (Americans) felt as if the British were hiding something because none of them would look them in the eye throughout the presentation. The failure of the British to look her in the eye almost “ruined the relationship and suck the deal,” she said. “I understand it now, but I still don’t like it”.

The amount of eye contact varies greatly among cultures. For example, in business meetings, the French will demand at least some direct eye contact. To refuse to meet someone’s eyes an unfriendly gesture. Compare this to the attitude of Japanese, who believe that the less eye contact, the higher the level of esteem. To divert eyes from a business colleague is a sign of respect and reverence. Rules about eye-language are numerous and complex. What has been mentioned gives a good idea of this; we shall not go further into detail.

### ***Facial expression***

As the most expressive part of the body, the face is probably the single most important source of non-verbal communication. It is capable of conveying several emotions simultaneously. The face not only can communicate a great deal, but also seemed to be the type of non-verbal behavior that people are best able to control. However, facial expressions should be interpreted in cultural context and with caution. Take for example smiles and laughter.

Smiles and laughter usually convey friendliness, approval, satisfaction, pleasure, joy and merriment. This is generally true in China as well as the English-speaking countries. However, there are situations when some Chinese will laugh that will cause negative reactions by westerners.

Other facial expressions also vary from culture to culture. For instance in some US businesses, it is considered acceptable to frown, swear, and yell, but not to cry. But for the Japanese in situations of strong emotion it is considered acceptable to smile or laugh, but not to frown or cry.

### ***Gestures***

Gesture is the expressive movement of a part of the body, especially the hand and the head. People talk with their hands, but what they mean depends on their culture. As with verbal language, non-verbal codes are not universal. Same gestures have different meanings in different cultures.

The forefinger near lips with the sound “shah”, which is a sign for silence in UK and America, means disapproval, hissing in China.

In different cultures different gestures are used for the same meaning. For coming here, Chinese gesture is a hand extended toward the person, open palm, fingers crooked in a beckoning motion; the American is a hand extended toward person, close hand, palm up, with forefinger only moving back and forth. For Americans, the Chinese coming-here gesture is like good-bye gesture. Many Chinese would see American coming-here gesture as offensive.

The same is true with some commonly used gestures. The OK sign (the circle formed with the thumb and first finger), which has the similar meaning in most of Western Europe, is a vulgar insult in Greece, an obscene gesture in Brazil, Mediterranean countries and Southern Italy, a sign for the sex act in some Latin American nations and can mean “you’re worth nothing” in France and Belgium .

Like hand movements, head movements differ from one culture to another. In Bulgaria, for example, people may nod their heads to signify no and shake their heads to signify yes. So gestures can be very confusing inter-culturally. But there are some gestures that have widely understood meanings. For example, foot-shaking, finger-tapping and fidgeting with a tie or hair usually signify nervousness or boredom; a clenched fist typically indicates hostility or aggression.

### ***Posture***

The way people carry themselves communicates volumes. People from different cultures learn to sit, to walk and to stand differently. The impact of culture on non-verbal communication is so strong that even people with great experience in cross-culture communication might be unaware of how meaning of a non-verbal act varies from culture to culture. The wife of a former president of the United States was said to have shocked her Arab hosts by crossing her legs during a public meeting, which is an indecent posture in Arab culture.

Posture offers insight into a culture’s deep structure. For instance, in the United States where being casual and friendly is valued; people often fall into chairs and slouch when they stand. In many European countries, such as Germany, where lifestyle tends to be more formal, a slouching posture is considered a sign of rudeness and poor manners. Similarly, in Japan, the formality is important and the Japanese value the ability to sit quietly. They might see the Americans fidget and shift as an indication of lack of mental or spiritual balance.

But there are similarities. For instance, even in North America, swinging a foot in interview makes negative impression. Also, people respond unfavorably to standing with

weight back on heels and hands in pockets at work place or sitting with feet up on the desk in office. And slouching or leaning on the lectern in business presentation may make the audience feel that the speaker's ideas are as careless as his or her posture.

Generally, standing erect, shoulders back, head held high display confidence, energy, and self-assurance, which gains more attention from the audience. And a relaxed posture, a comfortable seating position, uncrossed arms, and lack of stiffness indicate openness with no communication obstacles. On the other hand, abrupt movements, shifting seating positions, crossed arms or legs may signal defiance, disinterest or an unwillingness to listen.

### **Application of the Body Language in Negotiation**

Good negotiators know how to use body language to their advantage. They also know how to read other people's body language to gain the upper hand. Crossed arms, raised eyebrows, wandering eyes - they all mean something. Pay attention and you'll be surprised what you might learn about what is really going on in the negotiation regardless of what is being said with words.

#### ***Body language affects negotiation***

Body Language and Attitudes: Body language research has catalogued 135 distinct gestures and expressions of the face, head, and body. Eighty of these expressions were face and head gestures, including nine different ways of smiling. These gestures and expressions provide insight into the attitude of the originator. Simultaneous physical signals often reinforce each other and reduce the ambiguity surrounding the message. For example, eagerness is often exhibited with the simultaneous physical displays of excessive smiling along with frequent nodding of the head.

Common attitudes communicated nonverbally during negotiations can be grouped into two broad classifications—positive attitudes and negative attitudes.

Positive Attitudes: Positive attitudes indicated by body language may signal a sincere effort to achieve win/win results. Key indicators of positive attitudes are listed below.

Gestures: Be particularly careful when you are interpreting or using gestures. A gesture that means one thing in one society can mean something completely different in another. There is a good chance that you will encounter differing interpretations whenever you are negotiating with someone from another part of the world. Even if the other party is from the United States, some of these differing interpretations may remain as part of the person's heritage.

## **HOW TO USE AND UNDERSTAND BODY LANGUAGE IN NEGOTIATION**

### **How to use Body Language in Negotiation**

Using nonverbal communication can manage yourself and others. In negotiations, once you become aware of your counterpart's body language, you can change your own nonverbal communication. By putting your notepad on the table, sliding forward in your seat, and uncrossing your legs, you can change your position to a much more receptive

one. Once you begin to manage your nonverbal behavior and that of your counterpart, you will start reaping the benefits of “speaking the language.” Body language reflects people’s true feelings. The better you understand that language, the more you will be able to use it to your advantage.

In contract negotiation, you can use the knowledge of body language in several ways:

As you prepare for the negotiation conference, you should briefly review key elements of body language with members of the Government team.

The most important observation you can make about a room full of people is the personal space each person commands. Human nature dictates that people considered more powerful are typically awarded greater personal space by the other people in the room.

Control over the dominant chair (usually the head of the table) may be the most obvious sign of power. Once the spatial relationships are established, they are not easy to change. Take a moment before your next meeting and think about what relationship you want to establish with the other attendees. Arrange the seating accordingly.

### **Making First Contact**

Begin every meeting with great body language. Let your enthusiasm and energy show. Meet the other person’s eyes and give a good, firm handshake. Let the flesh between your thumb and forefinger meet the other person’s flesh between the thumb and forefinger. Press—do not squeeze—the hand. One pump accompanied by eye contact is plenty. One or two more may express great enthusiasm; any more than that can make the person uncomfortable.

Handshaking is far from uniform around the world. Germans are a nation of one-pump people. The French often shake one hand while putting the other on the opposing shoulder. The Japanese may forego the handshake for a bow.

### **Gauging Reception**

If you pay attention to body language early in a negotiation, you can spot signals of how receptive your counterpart is.

Legs and feet Sitting: Legs together, or on in front of the other slightly (as if at the starting line of a race). Standing: Weight evenly distributed, body tilted toward the speaker. Standing: Crossed legs, pointing away from the speaker. Sitting or standing: Legs and feet pointing toward.

Receptive people look relaxed with open hands, displaying the palms, indicating openness to discussion. They lean forward, whether they are sitting or standing. Receptive negotiators unbutton their coats. By contrast, people who aren’t willing to listen may lean back in the chair or protectively fold their arms across their chest. Having one leg up on the arm of the chair appears to be an open posture, but more often, this position signals a lack of consideration.

### **Seeing a Change of Heart**

Observing how someone is sitting or standing is the first step in reading body language—

but people aren't frozen like statues. Their positions and gestures change with their attitudes and emotions. Notice these shifts.

Looking out the window, holding the head up with one hand, doodling in a way that seems to absorb the doodler's complete attention, drumming fingers on the table all indicate that the listener is no longer paying attention.

One more thing to keep in mind: Body language works both ways. If your opponent is an experienced negotiator, chances are good that he or she will be observing your posture, gestures, breathing patterns, etc. Be aware of this and try to use it to your advantage. By using your body to transmit the appropriate message to your negotiating opponent, you can enhance the chances of securing the right deal and, just as importantly, keeping the negotiation amicable.

### **How to Understand Body Language in Negotiation**

Learning the language of nonverbal communications is almost as difficult as acquiring fluency in a foreign language. Reading body language is perhaps the most powerful form of human communication! And armed with the right information about reading body language, you can almost read people's minds. In addition to studying your own gestures and the meaning you are conveying, you must also become aware of what your counterpart is conveying.

#### ***Gesture Clusters***

Many skeptics argue that it is difficult to tell what someone is thinking by singling out one gesture—and they are right. A single gesture is like a single word; its true meaning is difficult to understand out of context. However, when gestures come in clusters, their meaning becomes clearer. For example, while a person's fidgeting may not mean much by itself, if that person is avoiding eye contact, holding his hands around his mouth, touching his face and fidgeting, there's a good chance he is not being totally honest.

Involuntary hand movements can be particularly telling. People often touch their nose, chin, ear, arm or clothing when they are nervous or lack confidence in what they are saying.

Legs: When asked why they cross their legs, most people say they do so for comfort. Although they are being truthful, they are only partially correct. If you have ever crossed your legs for a long period of time, you know that this position can become painfully uncomfortable.

Studying what you and your counterpart in the negotiation process are not saying is critical to achieving a win/win outcome.

### **CONCLUSION**

The study of body language should be complementary to the study of language in communications. The understanding of one should be helpful in the further understanding of the other. Some authorities feel that the two are dependent on each other. This is certainly true in most situations. But it is also true that in certain situations body action contradicts what is being said, just as the spoken words may mean something quite different from what

body language communicates. When this occurs, one must try to get further information, or guess the meaning from the context of the situation. In a sense, all body language should be interpreted within a given context; to ignore the overall situation could be misleading.

When one negotiates in a certain language, it is generally advisable to use the nonverbal behavior that goes with that particular language. Observation shows that a truly bilingual person switches his body language at the same time he switches languages. This makes negotiation easier and better.

A powerful piece of body language which you can have control over is the closeness between you and the buyer. To conclude a negotiation there needs to be a feeling of connection. If the buyer is well away from his desk or leaning back, place some brochures on the table but sufficiently far away that he has to come closer to you. You should then mirror his action and move closer as well. The end result is that you will be in a better position to strike a deal.

Trying to spot the body language, listen to what is being said and deciding what your next action takes practice and patience.

## REFERENCES

- [1] Fast Julius. (1971). *Body Language. Pocket Books*. N.Y.: Random House Value Publishing, Inc.
- [2] Jamesw .H ALL . (1994). *Body Language*. Chicago: The University of Chicago Press.
- [3] J o Toole. (1992). *The Process of Drano: Negotiation Art and Meaning*. London: Folcroft Library Editions.
- [4] Liu, Yongfa & Liu, Xuan'en. (1997). *The Practical Body Language*. BeiJing: Hua Wen Press.
- [5] RE Axtell. (1991). *The Do's and Taboo's of Body Language*. Boston: James Munroe.
- [6] Robinett, Betty W. (1978). *Teaching English to speakers of other Language: Substance and Technique*. N.Y.: McGraw-hill.
- [7] Samovar L. A. (1981). *Understanding Intercultural Communication*. London: Wadsworth Publishing Company.
- [8] Shen Minxian. (1999). *The Use of the Body Language in Elementary School*. Shanghai: Shanghai Education Vol.
- [9] Stern H. H. (1983). *Fundamental Concepts of Language Teaching*. London: Oxford University press.
- [10] T Morrison, WA Conaway & GA Borden. (1994). *How to Do Business in Sixty Countries*. Oxford: Oxford University Press.

# Teaching Communication as an Outcome Means

DR. APEKSHA MISHRA<sup>1</sup>

## Abstract

*using oral, written and interpersonal communication to inform, motivate and effect change is one of the eight Graduate Learning Outcomes. It is important for the graduates to have mastered the generic skill of communication in order to attain employment, be successful in their future careers and engage in professional written, oral and interpersonal communication with colleagues, clients and the general public. It is important that units and courses teach and assess communication skills in order to provide students with the opportunity to develop what are important employability skills. The following information is set out to assist, to explore, create and re-imagine what teaching and assessing communication as an outcome means.*

**Keywords:** Oral, Written, Communication, Assess

## WHAT IS COMMUNICATION?

Communication has traditionally been seen as verbal or non-verbal (Iksan et al. 2012). However, our understandings of communication are based on a rapidly evolving field that incorporates many different domains. These domains are not necessarily mutually exclusive and can transcend a traditional perception. These domains include face-to-face interactions, **digital literacy** including, email and texting, social media and virtual environments for instance, e-Portfolios, Facebook, Twitter, and Instagram. The protocols of communicating within each domain are different in regards to the length of message, the texts used for specific communicative purposes, intended audience, acceptable norms, nomenclature, spelling/grammar conventions, etc.

There are many elements to communicating effectively that individuals need to consider when entering into some kind of communicative interaction. Some of these elements include, the aim of the communication, level of formality (usually based on relationships of power and purpose for the communication), consideration of audiences' prior knowledge, cultural aspects etc. Some elements specific to oral, written and interpersonal communication are listed below:

### Oral Communication

- Empathy

---

<sup>1</sup> Assistant Professor, Acropolis Institute of Technology & Research, Indore (MP)  
E-mail: apekshamishra23@gmail.com



- Use of visual aids in a presentation
- Amount of information/detail in visual aides
- Provision of handouts
- Feedback from audience
- Engagement with audience
- Responding to questions from the audience
- Voice modulation
- Tone of voice
- Eye contact
- Presenter's positioning within the room

**Written Communication**

- Text type (e.g. report, case study, essay, reflective piece, annotated bibliography etc.)
- Appropriate length of document
- Structuring of the argument (usually presented as one main idea with supporting evidence for each idea)
- Appropriate level of detail within document (e.g. presentation of supporting evidence, referencing system)
- Ratio of white : black space (i.e., avoid long chunks of dense text)
- Font style/size
- Adherence to reference conventions (Harvard, APA, Vancouver etc.)

**Interpersonal communication**

- Emotional intelligence
- Body language
- Posture
- Sensitivity to the audience demonstrated through appropriate behavior
- Active listening

**WHY IS TEACHING COMMUNICATION AS AN OUTCOME IMPORTANT FOR ACADEMICS?**

The teaching of communication as an outcome, along with expert content, is important as it prepares students to better communicate through their assessment, enter into dialogue with peers and academics, formulate questions to further their learning etc. It is also integral to preparing for various professional environments and develops skills that are important as graduates, and sought after by employers.

**WHY ARE COMMUNICATION SKILLS IMPORTANT FOR STUDENTS?**

Effective communication skills are essential for University graduates to gain entry to and

be successful in, their future professions. Learning and developing effective written, oral and interpersonal communication skills will develop students' emotional intelligence and empathy through an understanding of their audience; these skills contribute significantly toward positioning graduates as **global citizens**.

In the workplace and professions, graduates will be required to communicate with multiple individuals – these may include:

- Colleagues
- Employers and managers
- Clients
- The media
- The general public

This communication could take multiple forms, for example:

### **1. Written Communication Applications**

- Proposals
- Applications for promotion
- Letters
- Memos
- E-mails
- Purchase orders
- Publications
- Reports
- Media releases

### **2. Oral Communication Oral Presentations**

- Meetings
- Client interviews

### **3. Effective Communication Skills will be Needed by Graduates for tasks such as:**

- Providing instructions
- Resolving conflicts
- Negotiating
- Sharing ideas

## **ASPECTS OF COMMUNICATION TO CONSIDER**

### **Culture**

Different cultures have different cultural norms in regards to communicating. In other words, what is acceptable within one culture may not necessarily be appropriate, meaningful

or even acceptable within another culture. Academics should be cognizant of some of the following cultural norms:

- In some cultures it is not appropriate for students to ask the lecturer questions in what can be deemed such a blunt way by some of our overseas students, nor to critique or question published work as this may be regarded as disrespectful. Thus, what can seem to the lecturer as passivity by students in the classroom can be misleading? In order to assist students engage more actively in the class activities it may be beneficial to explain to students in what ways questioning is regarded as appropriate, also to encourage questioning by eliciting student engagement right at the very beginning (e.g. today we are discussing (topic). What questions do you have about this topic before we start?)
- In some countries it is unacceptable to address academics by their first name. Thus ensure that you explicitly inform your students how you would prefer to be called to avoid any awkwardness.
- Students can also be uncertain about whether it is appropriate to contact their lecturer outside of class time. Thus it is worthwhile informing students how best to contact you (e.g. via email, phone, in person at a designated consultation time) when you meet them for the first time and in what time frame you intend to respond (if they email you).

### **English as a Second Language (ESL)**

Some 2 students within your class may be English as Additional Language (EAL) students. You may wish to draw students' attention to the services offered by experts and students can improve their communication skills as well as presentation skills. For upgrading their performances, students can use English as a Second Language.

### **Students Needing Assistance with their Communication Skills**

Despite being native speakers, students will always be challenged by their studies to develop their communication skills repertoire in different ways. However, should some students require specific assistance or support ensure they are direct to study skills and assessment support programs.

### **Students with Learning Difficulties**

Academics need to be aware that some students may have learning difficulties (such as an Autism spectrum disorder or dyslexia) and/ or impairments (such as visual, auditory and physical disabilities). To respond to these learning difficulties and/or disabilities inclusive teaching strategies or reasonable adjustments to complete assessment tasks may be drawn upon to ensure more satisfying teaching and learning experiences. For further information, please contact the **Disability Resource Centre**.

### **Inclusive Learning Strategies and Communication**

Adjusting to university can be especially difficult for some students. Some may have

difficulty expressing themselves due to language problems, social barriers or under-developed communication skills and may need assistance at various stages of their university experience.

There are a range of inclusive teaching strategies that can assist all students to develop good communication skills, and manage their study independently. For example, there are a variety of opportunities and models for building fluency in oral communication. First year students may commence with an audio recording, and then move onto a video recording of an oral presentation to demonstrate the same learning outcome. Performing in pairs can also build self-confidence. Students can then graduate to presenting their own oral with assurance and self-determination.

There are a number of resources in a variety of media to support the implementation of **Universal Design for Learning**.

### **Emotional Intelligence**

There is no one universally accepted definition for emotional intelligence, however, generally, but in general these definitions all relate to being able to understand one's own emotions, being able to regulate them and use emotions to guide our behavior (Seema 2012). Furthermore, emotional intelligence is about being able to understand other people's emotions and being able to respond to them in a culturally appropriate fashion (Seema 2012). Those who have an awareness of their own emotions and those of others and can integrate this information to guide their actions are said to have a high level of emotional intelligence (Seema 2012).

Emotional intelligence can be a useful tool for individual or team oral presentations or general teamwork interactions (also refer to **teamwork resource**). For example, generally, when giving an oral presentation the speaker can perceive the emotions of their audience and use this information to guide their talk. In this instance if the audience conveys the message of confusion via their facial expressions then the speaker will need to stop and clarify any misconceptions the audience may have had prior to progressing further. It is still uncertain as to whether emotional intelligence can be taught (Zeidner et al. 2002).

### **Body Language**

Communication is not just about verbal language but it is also about how our bodies are positioned within space. For example, in some cultures, individuals using up a lot of space via spreading their limbs and holding their head up are portrayed as being powerful whereas the contrast is true for those curled up with their arms crossed and their head down. Students can learn to be more powerful and assertive in presentations/ job interviews by controlling their posture and use of space. That is not to say that students should sit with their upper limbs in the air but they should not have their arms crossed and be hunched over looking downwards.

## **TEACHING COMMUNICATION SKILLS**

The substantial breadth and depth of what is meant by 'communication skills' means that

teaching these skills requires various techniques, tools and resources. These in turn, need to be modified depending on the experience of the student (e.g., a first year Bachelor student compared to a Masters level student). It is also important to remember that communication skills should be modeled and taught through different locations and mediums, for instance:

- Work integrated learning (Deveugele et al. 2005) – e.g., work and/or site placements
- Role-playing (Deveugele et al. 2005) e.g., scenarios of simulated learning
- Watching videos (Deveugele et al. 2005)
- Practicing in a virtual environment (Hussainy et al. 2012; Stevens et al. 2006).

Some general points to remember when teaching communication skills in teams:

- Teaching and assessing communication skills in teams and for individuals requires different techniques.
- The dynamics of the team also need to be considered when team communication presentations are being undertaken
- Team communication tasks will enable greater utilization of interpersonal communication as the team members will need to communicate with each other as well as the audience.
- Although a number of students will be nervous about communicating in a team, others may be overly assertive and this may need to be addressed during the process so that all students are able to develop communication skills.

### **Oral Communication**

Oral communication and public speaking can be one of the most confronting tasks for students and any stress may be increased when the presentation is being assessed.

- The following points give some guidance on how to teach oral communication:
- Place an appropriate weighting on the assessment – this should be high enough to recognize the importance placed on communication, but not so high that the assessment causes undue stress
- Clearly identify what is being assessed (e.g. content, structure, eye contact). This can be done by using a rubric such as those in ‘**Assessing communication skills and rubrics**’.
- Identify what will not affect the mark (e.g. hands shaking or voice tremors)
- Be aware of added complexity for students from diverse backgrounds
- Provide a safe environment for the students to present in
- Acknowledge to the class that there will be significant variation in presentations due to student’s previous experience in oral communication outside the specific course and the university (e.g. sporting club participation or part-time job). Provide opportunities for students who require more assistance.
- Model good oral communication in your lectures and tutorials
- Student preparation is very important
- Consider providing class time for ‘trial runs’. This can also provide opportunities for students to highlight concerns and be used for academics and peers to provide formative feedback.

Wilder (1999) outlines the Five fears of public speaking; understanding what these fears are can enable the academic to address them (Table 1).

**Table 1:** Wilder’s Five Fears of Public Speaking

<b>Career Terror</b>	Job-related functions – promotions, presentation to a ‘hostile’ boss, using new technology such as video conferencing, insufficient time to prepare, talking about unfamiliar topics
<b>Perfectionism</b>	Bright, clever, successful people with high standards and high achievement. When they have to speak they expect perfection and forget that it is about communication, not perfection.
<b>Panic</b>	Negative self-thoughts about forgetting words, shaking hands, etc. Your head becomes full of your fear, not your talk.
<b>Avoidance</b>	Self-sabotage – putting off deadlines and preparation. Can be rooted in perfectionism. The truth is – you put it off because of fear of failure – but when it’s done you almost always succeed.
<b>Trauma</b>	Memory of a specific incident or continuing experience. Being told you can’t do it – that you’re not capable.

Tips and suggestions that can ease student anxiety associated with public speaking are presented in Table 2. Although these specifically focus on public speaking, they could also be applied to decreasing anxiety with any form of oral communication.

**Table 2:** How to Manage Student Presentation Anxiety

<b>Convincing students of need</b>	When students understand the importance of oral communication in their studies and future professional role, they will actively participate in class activities.
<b>Model behavior from week one</b>	Establish a routine of dialogue in the first class session to set the pattern for subsequent weeks.
<b>Icebreakers</b>	Involve whole class in speaking in safe, interesting, fun ways.
<b>Be forthcoming</b>	Provide information about yourself, your interests and background.
<b>First meeting tasks</b>	Try to include some two-person tasks in first class. Then pyramid into a four-person group, which pools ideas and reports outcomes to class.
<b>Provide opportunities</b>	Include regular opportunities in class for oral expression, building from small tasks to larger tasks.
<b>Provide feedback</b>	Use peers to provide feedback – this allows for both sides to benefit from the experience.
<b>Self-assessment</b>	For formative and summative assessment – ask students to evaluate their own oral performance on pre-set criteria.

<b>Classroom arrangement</b>	Use seating patterns which allow eye contact between students, not just between students and teacher.
<b>Modular furniture</b>	Use tables and chairs that aren't fixed, if possible, as this allows moving from large group to sub-groups.

### Written communication

The three main components of written communication are:

1. Structure
2. Style
3. Content

Table 3 summarizes points that can guide students in reviewing their written communication in light of each of these components. These points can also be used to structure a lecture or tutorial to teach written communication.

**Table 3:** Questions for structure, style and content of written communication

Structure	<ul style="list-style-type: none"> <li>• discipline specific guidelines e.g., Psychology normally has strict constraints regarding the how to write Psychology reports</li> <li>• are the use of headings appropriate?</li> <li>• is there a logical introduction and conclusion?</li> </ul>
Style	<ul style="list-style-type: none"> <li>• is it concise?</li> <li>• check for clarity, brevity, simplicity, and humanity</li> <li>• length of sentences and paragraphs</li> <li>• avoidance of jargon</li> <li>• suitable for the audience (e.g. final year students, general public)</li> <li>• avoidance of repetition</li> </ul>
Content	<ul style="list-style-type: none"> <li>• check spelling and grammar</li> <li>• is there a logical argument?</li> <li>• are references relevant and contemporary?</li> </ul>

Other points to consider:

- Types of writing
- academic
- reflective
- creative
- scientific
- business/professional
- Students should understand that the easiest way to understand the conventions of the particular style of writing they are trying to undertake is to read multiple examples of that style. Academics may need to guide students in this process should that the examples that they are reading are of an appropriate level.

## REFERENCES

- [1] Bruner, JS 1960, *The process of education*, Harvard University, Cambridge, Massachusetts.
- [2] Deveugele, M, Derese, A, De Maesschalck, S, Willems, S, Van Driel, M & De Maeseneer, J 2005, 'Teaching communication skills to medical students, a challenge in the curriculum?', *Patient Education and Counseling*, vol. 58, no. 3, September, pp. 265–70, retrieved 3 June 2013.
- [3] Griffith Institute for Higher Education 2004, Griffith University, Nathan campus, Brisbane, Australia.
- [4] Hussainy, SY, Styles, K & Duncan, G 2012, 'A virtual practice environment to develop communication skills in pharmacy students', *American Journal of Pharmaceutical Education*, vol. 76, no. 10, December, p. 202, retrieved 3 June 2013.
- [5] Iksan, ZH, Zakaria, E, Meerah, TSM, Osman, K, Lian, DKC, Mahmud, SND & Krish, P 2012, 'Communication skills among university students', *Procedia: Social and Behavioral Sciences*, vol. 59, pp. 71–6, retrieved 3 June 2013.
- [6] University of Kent, *Communication skills: writing*, The University of Kent, Canterbury, Kent, retrieved 30 May 2013. Seema, G 2012, 'Emotional intelligence in classroom', *Advances in Management*, vol. 5, no. 10, October, pp. 16–23, retrieved 3 June 2013.
- [7] Stevens, A, Hernandez, J, Johnsen, K, Dickerson, R, Raj, A, Harrison, C, DiPietro, M, Allen, B, Ferdig, R, Foti, S, Jackson, J, Shin, M, Cendan, J, Watson, R, Duerson, M, Lok, B, Cohen, M, Wagner, P & Lind, DS 2006, 'The use of virtual patients to teach medical students history taking and communication skills', *The American Journal of Surgery*, vol. 191, pp. 806–11, retrieved 3 June 2013.
- [8] Wilder, L 1999, *7 steps to fearless speaking*, John Wiley & Sons, New York.
- [9] Zeidner, M, Roberts, RD & Matthews, G 2002, 'Can emotional intelligence be schooled? A critical review', *Educational Psychologist*, vol. 37, no. 4, pp. 215–31, retrieved 3 June 2013.
- [10] Zinsser, W 2010, *Writing places*, HarperCollins, Australia.



# Digital Innovation Strategy: A Framework for Diagnosing and Improving Digital Product and Service

ASHIMA RATHEE<sup>1</sup> AND MEENAKSHI BHASKAR<sup>2</sup>

## Abstract

*Digital technology is increasingly important in achieving business goals, and its pervasive effects have resulted in the radical restructuring of entire industries. Consequently, managers' extensive interest in handling digital innovation is not surprising. Recent research has illustrated how digital technologies give rise to a vast potential for product and service innovation that is difficult to control and predict. Therefore, firms need dynamic tools to support themselves in managing the new types of digital innovation processes that emerge. The nature of these processes forces firms to challenge prior assumptions about their product and service portfolio, their digital environment, and ways of organizing innovation work. In this article, we present a managerial framework that supports firms in this undertaking. The framework, geared at supporting ongoing improvements in digital innovation management, covers five key areas: user experience, value proposition, digital evolution scanning, skills, and improvisation. We also present a diagnostic tool that can be utilized as firms begin the process of implementing the framework. Finally, we conclude with our thoughts on the managerial implications of the framework when going forward in a rapidly changing digital innovation landscape.*

## INTRODUCTION

### Digital: Opportunity or Threat?

Leading business schools offer digital business strategy training that allows you to identify digital technology opportunities, as well as threats. By understanding such concepts as digital disruption you can better prepare your company to deal with emerging competition that threatens your value proposition and market position.

Such management training will also familiarize you with such digital innovations as the Internet of Things, big data, social media and cloud computing. You will learn how your company can use these innovations to boost performance. You will discover how the latest digital trends can help you create exceptional value for your customers.

---

<sup>1</sup> Associate Professor, Mangalmai Institute of Management and Technology, Greater Noida  
E-mail: ashima82@gmail.com

<sup>2</sup> Assistant Professor, Mangalmai Institute of Management and Technology, Greater Noida  
E-mail: bhaskarmeenakshi1986@gmail.com

**Digital Innovation Strategy**

Digital technology has become a very important part in defining the success and downfall of firms. As it is giving rise to many different technologies every day, firms do not have a certainty of surviving this ever changing market. In order to be successful as well as remain a competitor, firms need dynamic tools to support themselves in managing the new types of digital innovation processes that emerge. The nature of these processes forces firms to challenge prior assumptions about their product and service portfolio, their digital environment, and ways of organizing innovation work. Under the notion of customer-driven digitization, organizations across all industries need to heavily invest in transforming and innovating their business (processes) to become digitally literate and have a framework for supporting ongoing improvements in digital innovation management. The framework, geared at supporting ongoing improvements in digital technology management process, covers five key areas: user experience, value proposition, digital evolution scanning, skills, and improvisation.

**Digital Transformation: A Framework for Radical Innovation**

What to make of the abundance of management literature touting innovation as a remedy for all that ails an organization? First and foremost, all roads to innovation are not equal: incremental innovation, which is very similar to ongoing improvement, cannot provide miracles. The best results are obtained with breakthrough or radical innovation, making it possible to achieve technological and operating excellence. These two focal points are the result of innovation and organizational transformation, but are also crucial in underpinning the two key objectives for a digital business that differs from the rest:

Improve the client experience, for example using a centralized client file that provides a comprehensive picture for each client's history and characteristics and that suggests the next steps to take or recommended goods and services.

Improve the effectiveness and level of commitment of employees and partners. Modern day companies no longer operate in isolation. They must differentiate themselves by pooling their resources and know-how. Finally, the importance of employee commitment has already been established.

Recent researches indicate the rising innovation in the industries that even has become unpredictable. Thus, firms need more innovative tools to manage this rapid digital innovation process that are emerging. Such extensive forces required the firms to modify their prior strategies about their product and service portfolio, their digital advancement, and ways of organizing innovation work.

A managerial framework is being presented in this article that supports the firms in this. The framework helps to support the ongoing improvements in digital innovation and cover all these five areas including user experience, value proposition, digital evolution scanning, skills, and improvisation.

While implementing the framework a diagnostic tool, present in the article, could also be utilized. In the end, it concludes with opinions on the managerial implications of the framework while moving ahead in a rapidly changing digital innovation environment.

Few key areas to be measured and evaluated in seeking to manage digital product and service innovation:

### **User Experience**

One of the key areas of digital management process is user experience. While using a website, a Smartphone or any digital platform the user experience needs to be excellent. Web navigation has to be smooth while based on filtering functionalities that allow users to easily navigate and reach at the desired product in a few clicks. The firms should not only consider the browsing and usability experience rather they should also focus on customer's experience of interacting with these web- sites. They must focus on the aesthetic properties of digital products and services as users are affected by beauty and appearance also. Creating an integrated user experience that evokes engagement is most important when moving beyond websites and desktop applications which can be done through obtaining a composite measure of the levels of usability, aesthetics, and engagement in firm's digital products and services.

### **Value Proposition**

Value proposition is the processes of value creation involving the value network around the firm, including suppliers, customers, and third parties. The value proposition of digital products and services is evaluated through assessing three elements, beginning with customer segmentation. This involves analyzing the customer base in order to make strategic decisions about how to reach different groups of customers with the products and services in the firm's digital portfolio.

Firms need to decide how the products and services in their digital portfolio can be differentiated and bundled. They need to balance premium and free and the role of advertising in each of the firm's digital products and services, as well as defining boundaries between them while defining units in each of them. Firms engaging in digital innovation need to deal with commissions of channel owners so they need to know how to negotiate the commission of channel owners. To this end, iTunes challenged the music industry's established bundling model by pricing tracks instead of albums.

### **Digital Evolution Scanning**

Digital evolution scanning involves identifying new opportunities for innovation. As digital innovation emerges in these acts of recombination, firms need to continuously consider how they can be active participants. Digital technology evolves itself by first starting with a simple hardware and software combination and later over the time into more and more sophisticated

**DRIVERS OF THE FOUR KEY THEMES OF DIGITAL BUSINESS STRATEGYZ**

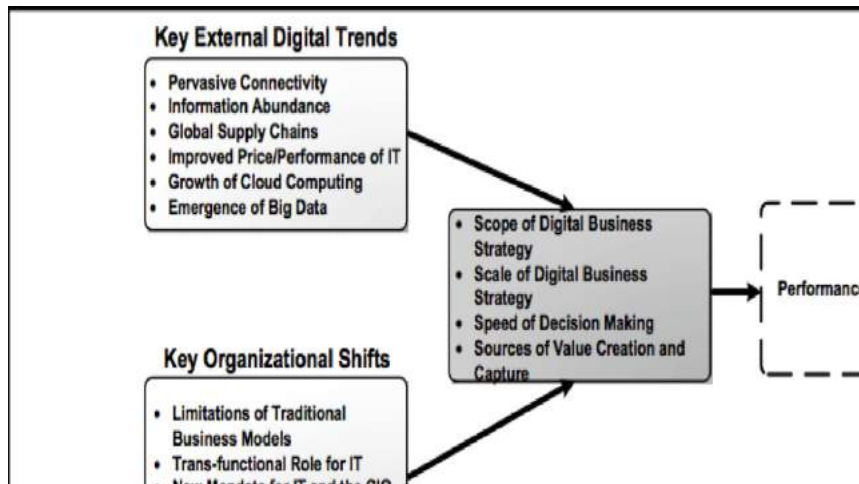

**Digital transformation framework**

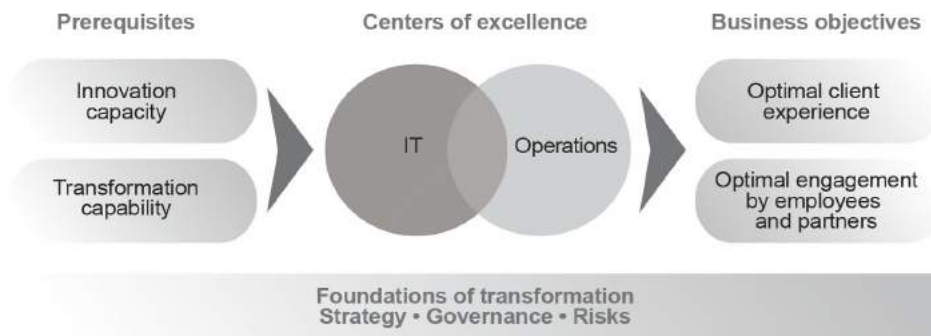

**Innovation capacity and transformation capability: Two essential elements that go hand in hand**

Only 71 of the companies listed on the Fortune 500 in 1955 still exist today. Why? In my view, this is due to two key factors: a company’s innovative capacity and its capability to be transformed while capitalizing on innovation.

**Transformation capability** refers to organizational agility and the courage to invest in practices that foster innovation (the tools, methods and type of organizational climate that provide fertile ground for innovation will be discussed in more detail in an upcoming article). Transformation capability is not a standalone process: to achieve this optimum result, oversight in the form of various governance mechanisms that transcend company silos is required. The goal has more to do with broader innovation management as compared to sporadic or occasional innovation. Once again, I am opposed to incremental innovation, which is often necessary albeit clearly inadequate.

**Innovation capacity** refers to an organization's ability to put in place all the necessary elements that are conducive to innovation, namely market intelligence, openness to clients, time-to market, and development of the proposed goods and services at optimal prices. Today, all companies are able to acquire equivalent means and infrastructures (technology, know-how, services), for about the same price, which includes patents. In other words, there are no more excuses. Combining innovation capacity and putting in place these resources provides the real added value in a digital business strategy—one that will allow the company to set itself apart and become a leader in its field. Just like the method of establishing the business strategy, which must be both innovative and customized, the method of innovation and the objective being sought must be innovative in their own right to guarantee the success of any differentiation strategy.

However, there is no magic formula. To provide results, the strategies used must be interconnected and carried out on a simultaneous and ongoing basis—somewhat like having a business operate during renovations. It is also important to remember that innovation in itself is no guarantee for a company's success. Although it may be necessary—even crucial—for a company's survival (always remember Kodak), it is also important to use this lever to transform business practices as well as the business strategy. For optimal results, innovation and strategy must go hand in glove.

### **Aligning Strategy and Innovativeness: The First Step Towards Excellence**

According to a Harvard Business School study, 75% of companies examined have a tendency to make ongoing improvements in the same way, with few real benefits, rather than examining new products, services or markets. This failure to innovate stems mainly from the lack of an ongoing innovation process, an obsession with daily operations management to the detriment of the business models of tomorrow, a limited understanding of stated and unstated client needs and, finally, a lack of collaboration both within the organization and with external partners. The emergence of new business models, which is encouraged, is a testament to this crucial alignment between the company's strategy and innovativeness: the sharing of assets (car, tools, accommodations, etc.), the sharing of production capacity, the return of barter transactions, the sharing of insurance and finance risks, community fund-raising... there are many ways to use innovation in order to transform an organization's business strategy.

The following are some tips to plan and put in place the business models of tomorrow immediately:

- Involve all business lines in the strategic planning process;
- Incorporate innovation to stimulate strategic planning;
- Gather and analyze the appropriate data, e.g., by way of benchmarking, to provide the necessary information for strategic planning;
- Put in place a value management framework to measure the benefits of the new strategy;
- Never under-estimate the necessary balance that must be achieved between the transformation strategy and operations management.

What if the greatest risk is not just missing out on digital transformation and not having the courage to invest in innovation and modernization? What if the pitfall were failing to harmonize innovation and management practices? Today's strategy requires another strategy, just like innovation requires new innovative approaches. In upcoming articles, I will discuss in more detail how to put in place innovative business strategies as well as governance mechanisms making it possible to support these strategies and how to mitigate some of the related risks.

## REFERENCES

- [1] Amit, R., and Schoemaker, P. 1993. "Strategic Assets and Organizational Rent," *Strategic Management Journal* (14:1), pp. 33-46.
- [2] *Information Systems Journal*, 19 (4) (2009), pp. 345–367
- [3] [https://en.wikipedia.org/wiki/Digital\\_India](https://en.wikipedia.org/wiki/Digital_India)
- [4] [http://www.worldwidejournals.com/indian-journal-of-applied-research \(IJAR\)/file.php?val=Octer\\_2015\\_1444211851\\_\\_223.pdf](http://www.worldwidejournals.com/indian-journal-of-applied-research-(IJAR)/file.php?val=Octer_2015_1444211851__223.pdf)
- [5] [http://www.csiindia.org/communications/CSIC\\_April\\_2015.pdf](http://www.csiindia.org/communications/CSIC_April_2015.pdf)
- [6] <http://digitalindiainsight.com/what-is-digital-india-campaign>
- [7] <http://www.mapsofindia.com/my-india/government/modis-digital-india-plan-faces-real-worldchallenges>
- [8] [www.richter.ca/en/News-and-Media/News-and-Insights/Digital-innovation-at-the-heart-of-a-business-strategy](http://www.richter.ca/en/News-and-Media/News-and-Insights/Digital-innovation-at-the-heart-of-a-business-strategy)

# Data Security Approaches: Data Warehouse Components

NIRMAL SHARMA<sup>1</sup> AND SUSHIL K MAURYA<sup>2</sup>

## Abstract

*Data warehouse holds huge volume of ancient figures from dissimilar active resources and runs multidimensional assessments, to giving delicate and serious statistics which support to decision-makers, recover the society's commercial procedures. Organizations that have a strong security used to effective processor surroundings are additional as to pay attention to security issue for data warehouse on different domain. At present is accessible data security approaches, concentrating on exact situation and necessities use in data warehouse applications. In this paper has argument to contents and prospects for upcoming study. It assistance in considerate the several security features associated to Data warehouse. Data warehouse components are used for security purpose its extraction, transformation and cleaning data in organization.*

**Keywords:** *Data Argument, Data Security, Data Warehouse Component Integrity*

## INTRODUCTION

Additional security structures move the presentation of the data warehouse; consequently it is vital to control the security requirements quick probable. It is problematic to enhance security structures subsequently the data warehouse has disappeared in organization. If security processes are followed by user access, data load, request and movement. It requests to mainorganize the data and then organize the users on the source of the data they can access.

Application development security moves the complete application development and it also moves the strategy of the vital components of the data warehouse such as extraction, transformation and cleaning data. The supervisor may involve inspection encryption to clean highest and residence them in dissimilar positions [1].

It produced and sustained additional interpretations, the warehouse supervisor may need additional encryptions to implement security. Additional instructions may have to be implied into the data warehouse to avoid it from being misled into affecting data into a position where it should not be accessible. The query supervisor needs the alterations to handle any access limitations. The query supervisor will essential to be conscious of all additional interpretations and combinations [2].

---

<sup>1</sup> Research Scholar, Computer Science, Teerthanker Mahaveer University Moradabad, (UP)  
E-mail: nirmal1709@rediffmail.com

<sup>2</sup> Associate Professor, MIMT, Greater Noida (UP)

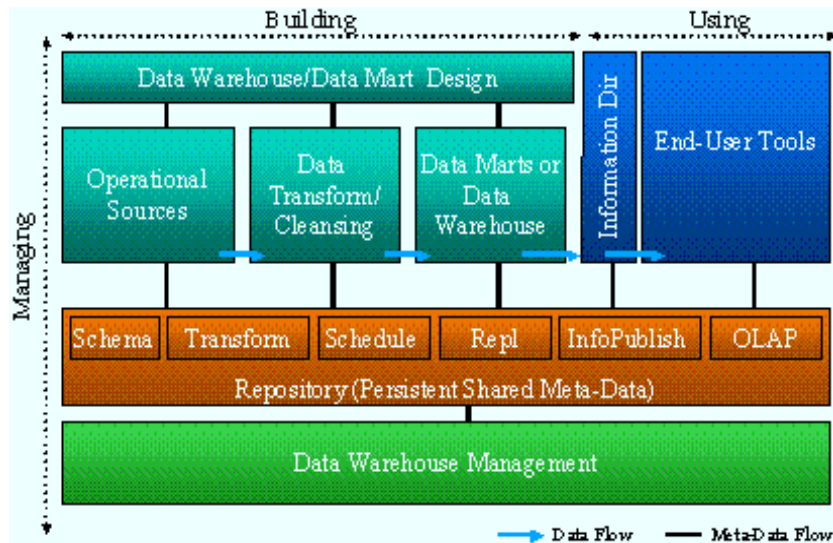

**Figure 1:** Data Warehouse Components

The data warehouse builds to require a set of components for recitation the logical and physical strategy of the data sources and their destinations in the initiative data warehouse.

To adapt to explanation srested out throughout the strategy period, functioning data must permitover a cleansing and transformation period before being positioned in the initiative data warehouse. Above figure shows to process can be numerous stages deep, particularly with initiative data warehousing architectures simplified [3].

User tools are including desktop efficiency products, dedicatedstudy products, and routine programs to improvement access to data in the data warehouse.

User access is over a manualability that allows user searches for proper and applicable data to determination queries between the users and the data warehouse systems.

Avariation of components can originate into show for the organization of the data warehousing location and repeating tasks.

The Data warehousing structure describe the associations between the numerous components used in the process of constructing and managing it.

OLE DB runs for consistent, high-performance access to a extensive selection of data and permits for incorporation of numerous data categories.

Repository runs an incorporated data repository that is shared by the numerous components used in the data warehousing process [4].

## DATA WAREHOUSE SECURITY REQUIREMENTS

These requirements suggest numerous security issues to confirm that it is just legal users who assistance from applicable data and that no illegal sources are accessed. Under numerous authorities it is illegal to combine individual data except secrecy can be confirmed by organization. There are main necessities and influences on the collection of suitable



security data warehouse situation. This security should sustainancestructures and controller access to separate data items, selective encryption and original security procedures. They comprehend security information as access instructions, organizations of security objects or permissions of security focuses [5].

Basic requirements are used for security purpose. The application must avoid illegal users from retrieving or altering data, the applications and original data must not be vulnerable to data-theft by hackers, the data must be accessible to the correct users at the accurate period, and the system must retain a record of events achieved by its users. These necessities are possibly uniform.

A data warehouse holds data consolidated and vital information from numerous sources, and thus from the outlook of a mean individual annoying to steal information a data warehouse can be one of the most profitable goals in an initiative.

### **Current Scenarios of Clients are Included for Data Warehouse Security**

- A corporation is handling an initiative data warehouse that will be extensively applied by numerous separations and firms. That corporation requirements a security setup that confirms that the staffs of each partition to only be capable to interpretation only the data that is applicable to their own partition, though also permitting for staffs in its commercial workplaces to interpretation the complete depiction.
- Every organization stores whole information of employee. The observance to these confidentialityrules must be realized in the data warehouse.
- An organization retails statistics from a data warehouse to its customers. Those customers may only interpretation the statistics to which they have acquired or pledged. They are competitors [6].

### **Data Warehouse Security Components**

*Mitigated security risk:* It is mitigated security risk is to deliver numerous coatings of security tools, so that disappointment of a solitarytool does not outcome in cooperation of acutematerial. Oracle Databases can also performance security and scalability purposes by allowingmerging and layering database-enforced security that cannot be avoided.

*Supervisory Access:* must be confirmed and delicate data. Whenever, database users arecreating the data warehouse to connect administrator. They frequently must edge a specific user's access to the equal of distinct records in a database table.

*Front-end applications:* Above figure shows data warehouse to connect to Sales and focus group it is collection the information and reduced the information of each group. Organizations structure is implemented to firm, rough access control by construction request code in each of the front-end applications. Preserving this type of compound access control code is not only expensive, but also risk-prone. For these major details, administrations that comprehend this hard-to-solve difficult figure safety as a whole, and access control.

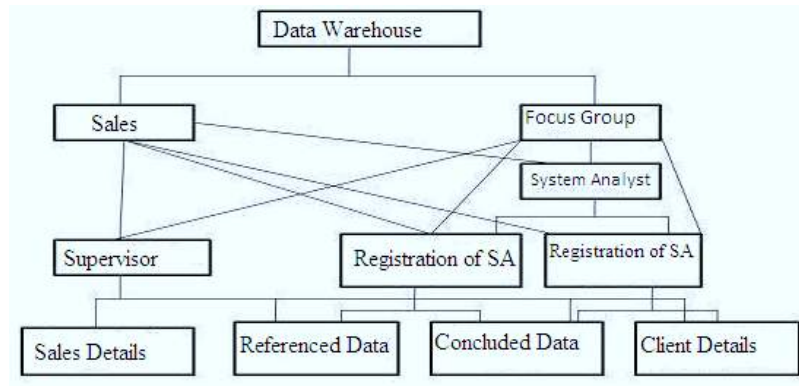

**Figure 2:** Role Access Hierarchy Data Warehouse

*Load and Transferring:* Earlier the data can be loaded into the data warehouse; it must first be transformed into a combined and reliable arrangement. A transformation is a order of technical processes that is functional to the material in a data source before it can be stored in the state dendpoint.

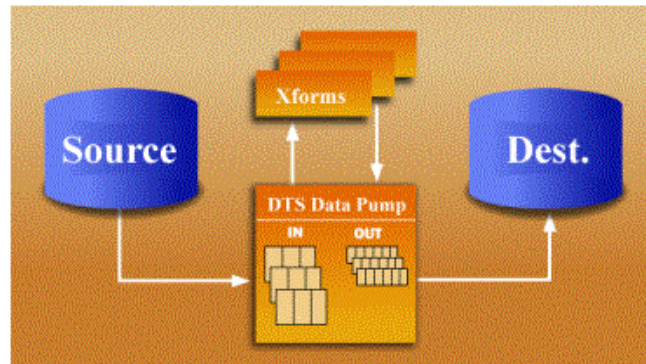

**Figure 3:** Data Transformation Services

*Data Transformation Services (DTS):* is a originalability in Microsoft SQL Server 7.0 that chains many categories of alterations, like modest pillar mappings, control of original standards from one or more cause fields, decay of a solitary field into numerous endpoint pillars. Above figure shows what is the basic aim of DTS are:

- To offer improved introducing, spreading, and alteration of heterogeneous data.
- To offer an extensible architecture available in database, clients, and advisors.
- To share rich piece of information around the sources, destinations, alterations, and ancestry over addition with data warehouse.

## DATA WAREHOUSE CASE STUDY

This case study shows how to improvement and secure the government sector' data warehouse. A local government formed a data warehouse to examine crucial metrics likes

economic and outlay statistics. Meanwhile respectively section should only be able to interpretation the economic statistics for their personal section, the data warehouse Security implemented in Virtual Private Database. During this approach, individually of the 28 government sections has its individual 'virtual data mart'; from the viewpoint of the end-users inside a government section, the organization looks to be a data mart covering only their sections' data. Moreover, the government's interior reviewing section can apply this identical data warehouse to recover combined economicstatistic scross ways all sections. This government has used a data-mart appear and touch to respectively of its 28 sections, though profiting from the cost-savings of applying a solitary scheme and achievement the capability to organize combined study [7].

### **Extra Protection with Encryption**

Number of database has lot of security techniques but every system has individual technique of security. Oracle supports encryption of network circulation, by way of it has since Oracle7. Industry-standard algorithms, like Data Encryption Standard (DES), Triple-DES and AES, defend Oracle network circulation, together among workstations and servers and among database servers. Between other database security actions, Oracle also defends data stored in warehouses through encryption inside the database. While encryption should never be used as extra for actual access control, one can attain an extra degree of security by selectively encrypting delicate statistics, like credit card numbers, earlier it is deposited in the database. The Oracle Database offers a PL/SQL package that encrypts and decrypts deposited data [8, 9]. It also offers an arbitrary number producer, because arbitrary numbers are mandatory to produce secure encryption keys are:

- Backup encrypted or decrypted varieties?
- Temporary data to be held
- Create data such as observable

### **CONCLUSION**

Data warehouse is permitting the users to abstract statistics around the commercial as entire data. Then we recognize the security boundaries used on the statistics that can be problem for retrieving the figures. The data from each expert can be concise and approved on to organization anywhere the dissimilar reviews can be combined.

Security facets should previously be measured in the enterprise stage of the data warehouse to improve competition the security requests and to escape advanced central, cost-intensive variations. DTS allocates one interpretation of concentrated data warehouse to the every solitary user group. Users of this user group can easily direct over the condensed statistics of the data warehouse. Data warehouse components are used and identified for security purpose its extraction, transformation and cleaning data in organization that particular component is secure the data for encryption. Organization trusts clients capitalizing in data warehouse technology created on the particular platform are producing applications through the greatest probable financial thoughts, although preserving the occupied scalability and consistency of their structures.

## **REFERENCES**

- [1] N. Katic, et.al, "A Prototype Model for Data Warehouse Security Based on Metadata" Institute of Software Technology (E188) Vienna University of Technology.
- [2] Pernul, Günther Pernul, "Database Security Advances in Computers", Vol. 38, p. 1-72, 1994.
- [3] Slemo Warigon, "Data Warehouse Control and Security Association of College and University Auditors LEDGER", Vol. 41, No. 2, pp. 3-7 April 1997.
- [4] [msdn.microsoft.com/en-us/library/aa226163\(v=sql.70\).aspx](http://msdn.microsoft.com/en-us/library/aa226163(v=sql.70).aspx)
- [5] Sam Anahory, Dennis Murray, "Data Warehouse", AddisonWesley, 1997.
- [6] Kristy Browder Edwards, George Lumpkin, "Security and the Data Warehouse" Oracle Corporation World Headquarters 500 Oracle Parkway Redwood Shores, CA 94065 U.S. A. April 2005.
- [7] [www.tutorialspoint.com/dwh/dwh\\_security.htm](http://www.tutorialspoint.com/dwh/dwh_security.htm).
- [8] Alex Berson, Stephen j. Smith, Data Warehousing, Data Mining & OLAP, McGraw-Hill Series on Data Warehousing and Data Management, 1997.
- [9] R. Kimball, "The Data Warehouse Toolkit - Practical Techniques For Building Dimension Data Warehouse", John Wiley & Sons 2001.

# Human Resource Management: Issues, Challenges, Functions and Model

KIRAN TIWARI<sup>1</sup> AND D N TIWARI<sup>2</sup>

## INTRODUCTION

Human Resource Management is the strategic and coherent approach to the management of an organization's most valued assets - the people working there who individually and collectively contribute to the achievement of the objectives of the business. HRM means employing people, developing their capacities, utilizing, maintaining and compensating their services in tune with the job and organizational requirement. The role of the Human Resource Manager is evolving with the change in competitive market environment and the realization that Human Resource Management must play a more strategic role in the success of an organization. Organizations that do not put their emphasis on attracting and retaining talents may find themselves in dire consequences, as their competitors may be outplaying them in the strategic employment of their human resources. With the increase in competition, locally or globally, organizations must become more adaptable, resilient, agile, and customer-focused to succeed. And within this change in environment, the HR professional has to evolve to become a strategic partner, an employee sponsor or advocate, and a change mentor within the organization.

## HRM FUNCTIONS

Human Resource Management is concerned with the "people" dimensions in management. Since every organization is made up of people, acquiring their services developing their skills, motivating them to high levels of performance, and ensuring that they continue to maintain their commitment to the organization are essential to achieving organizational goals. To look HRM more specifically we suggest that it is a process consisting of four functions:-

- Acquisition Function
- Development Function
- Management Function
- Motivation Function

In recent years, more emphasis was given on manpower because of the change in the society, attitude of an individual etc. etc. In a study ASID i.e. the American Society for Training and Development Recognized Nine Arms of Hrm.

---

<sup>1</sup> Assistant Professor, Dhoracharya PG College, Dankaur, GB Nagar

<sup>2</sup> Associate Professor, IIMT Group of Institutions, Greater Noida

- Training and Development
- Organization and Development
- Organization/Job Design
- Human Resource Planning
- Selection and Staffing
- Personnel Research and Information Systems
- Compensation/Benefits
- Employee Assistance
- Union/Labour Relations

**Human Resource Management Model**

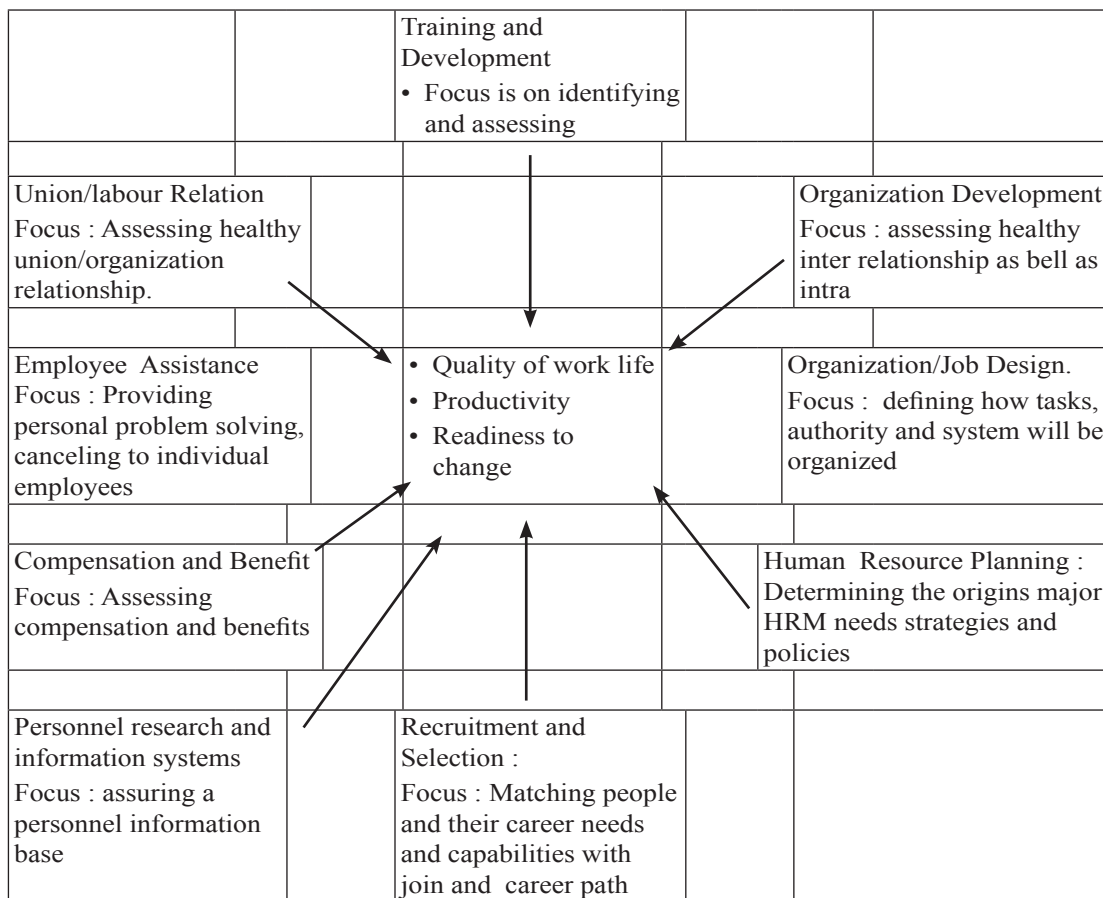

**ISSUES AND CHALLENGES**

<b>Executive Management</b>	Coaching and mentoring for individuals or groups Executive development Strategic business expansion planning and downsizing Employee retention Diversity plan design
Employee Relations	Sexual harassment Employee conflict resolution Affirmative action planning Performance management and disciplinary action Workplace violence Work life issues Email abuse and electronic monitoring Contingent workforce issues
Organizational Development	Leadership and team building Change management Succession planning and organizational design Merger/acquisition integration and implementation
<b>Compensation and Benefits</b>	Severance plan drafting and interpretation Disability claims management Evaluation of employee assistance programs Strategizing solutions for Fair Labor Standards Act (FLSA) and pay equity issues Implementing compensation structures

**CONCLUSION**

The respect for the field of human resources is increasing as HR workers are being trained in operations, marketing, finance and other important areas. Although challenges are still present, collaborative efforts to meet those challenges are stronger.

**REFERENCES**

- [1] The Challenges of Human Resource Management by: Dr Alvin Chan
- [2] October 12th, 2009 Gireesh Sharma Posted in Compensation Planning, Economy, Employee Appraisals, Employee Rewards, Performance Management
- [3] Grimme's Top Ten Tips to Attract, Retain and Motivate Employees by Don Grimme
- [4] McLean G. N. National Human Resource Development: A Focused Study in Transitioning Societies in the Developing World. In *Advances in Developing Human Resources*; 8; 3, 2006.
- [5] Lawrence J.E.S. Literacy & Human Resources Development: an Integrated Approach. Reprinted in Special Edition of *Annals of the American Academy of Political and Social Science*. World Literacy 2000. Daniel Wagner (Ed.). 2000, Volume 520

**SECTION 5**

**Emerging Business Models**





# A Paradigm Shift Towards Pro-People and Pro-Active Better Governance Initiatives of India

DEEPTI SHARMA<sup>1</sup> AND VIKAS MISRA<sup>2</sup>

## Abstract

*This paper starts with the fundamental prerequisites for quality governance of India prevailing since ancient times. This paper has been analyzed from the perspective of the recent major initiatives taken up by the Government of India towards better governance and also to assess the impact and bottlenecks in the implementation of better governance initiatives. The aim of the study is to understand the various functioning of the Indian Governance system and to measure the major yardsticks in the effectiveness and efficiency of recent major initiatives of Government of India mainly Make in India and Start ups. Notably there is a growing interest to the concept of good governance which has come to center stage in 1990's. In the present scenario, the guiding philosophy of the Government of India is to do a better job of delivering on governance. The main purpose is to raise public awareness amongst the citizens and also to develop a holistic approach in contributing the better governance initiatives. This would contribute significantly in bringing the citizen more closer to the government and will become an active participants in the governance process.*

**Keywords:** *Good Governance Initiatives, Make in India, Start ups*

## INTRODUCTION

India is a vast country with diverse terrain, culture, different languages, socio-economic groups and varied standard of living. The Indian states have different levels of social, political and economic development. India's economic development largely depends upon the Government policies and their implementation. Moreover, Indian Government is viewed as a strategic organization and for the development and progress of a progressive country like India, there is a need to better understand the various functioning of the Indian governance system. The term governance refers to the formulation of policies and continuous monitoring of their effective implementation, identifying bottlenecks and subsequently initiating corrective action by the members of the governing body of an organization. It includes the mechanism required to balance the powers of the members

---

<sup>1</sup> Assistant Professor, Manyawar Kanshiram Institute of Tourism Management, Lucknow  
E-mail: [deepti.sharma.sama@gmail.com](mailto:deepti.sharma.sama@gmail.com)

<sup>2</sup> Professor Allenhouse Institute of Technology, Kanpur  
E-mail: [vikas.rml@gmail.com](mailto:vikas.rml@gmail.com)

and the primary duty of enhancing the prosperity and viability of the organization. The term Good Governance is relatively not a new term to the Indian society rather the principles of Good Governance were followed by the rulers of ancient India. Even in the great epics of Mahabharat and Ramayana, the rulers abide by the principles of Good Governance which are more often cited in many occasion. Chanakya was also a pioneer in evolving principles of economics, rajdharama and the social warfare in particular and efficient administration of the state in general.

Various system evolved in those days can be seen even today. As a matter of fact, in the present scenario, the focus is more on the concept of “Better, Speedy and Transparent Governance” rather than “Good Governance”. The vision and the proposed roadmap of development of country as given by Shri Narendra Modi and his guiding philosophy appears to be that the respective states will continue to play a major role, and his government will create the path of formation of policies & its effective implementation by smooth, speedy and transparent governance. Recently, the Indian government has taken initiatives to make India towards better governance. In this regard, this paper attempts to understand the evaluation on good governance initiatives.

Governance is “the process of decision making and the process by which decision are implemented (or not implemented). The term governance can apply to corporate, international, national, local government or to the interactions between other sectors of society. According to the United Nation Development Program(UNDP), “governance can be seen as the exercise of economic, political, and administrative authority to manage a country’s affairs at all levels. It comprises the mechanism, processes and institutions, through which citizens and group articulate their interest, exercise their legal rights, meet their obligations and mediate their differences”.

Studies of the World Development Report 1997 has also underlined the effectiveness of the state as an essential prerequisites for economic growth, eradication of poverty and hunger and sustainable development. Its central idea of good governance encompasses the participatory, transparency and accountability. It is also effective and equitable and it promotes the rule of law. According to Surendra Munshi, good governance “signifies a participative manner of governing that functions in a responsible, accountable and transparent manner based on the principles of efficiency, legitimacy and consensus for the purpose of promoting the rights of individual citizens and the public interest, thus indicating the exercise of political will for ensuring the material welfare of society and sustainable development with social justice”.

The approaches of good governance for India have been based upon the principles of Mahatma Gandhiji’s concept of ‘Ram Rajya’ and ‘Swaraj’. Mahatma Gandhi was a believer in the importance of self-government and believed every village must be empowered to deal with local issues. For effective functioning of good governance, every citizen must be empowered and has right to be informed, express their views which must be heard and considered, participate in various decision-making processes of governance and contribute in meaningful ways.

## **Major Initiatives**

Recently several major initiatives have been taken up in India for empowering common man and for effective functioning of governance. This is evident from few dynamic initiatives taken up by Government which include Jan Dhan Yojna, Swachh Bharat Mission, Make in India, Startup India, e-governance in particular. This paper mainly outlines the two recent major initiatives of Government of India which includes Make in India and Start ups. An attempt has also been made to analyze the impact and bottlenecks in the implementation of good governance initiative.

### **1. Make in India**

By Inviting global companies to India, Prime Minister Shri. Narendra Modi launched the campaign 'Make in India' on September 25, 2014. Mr. Modi first mentioned the words 'Make in India' during his maiden speech as PM on Independence Day. The initiative has been taken to boost the economy of the country by inviting global companies to invest in the Indian market. Economics did find a mention in that Prime Minister Shri Narendra Modi outlined a vision of India manufacturing rather than importing the goods it needs. The "Make in India" campaign aims to make India a leader in manufacturing by 2020 by creating exports worth \$990 billion. The major objective behind the initiative is to focus on 25 sectors of the economy for job creation and skill enhancement. It also aims at high quality standards and minimising the impact on the environment. The initiative hopes to attract capital and technological investment in India. Make in India is an initiative of Government of India, to encourage companies to manufacture their products in India.

### **2. Start ups**

Prime Minister Narendra Modi has kicked off the ambitious Startup India Movement. The government programme aims to fill gaps in the economy for the growth and development of startups and will aim to boost digital entrepreneurship at the grassroots. The government is expected to earmark around Rs 2,000 crore for the initiative. "The much awaited unveiling of #StartupIndia by Prime Minister of India has brought lots of positivity among the entrepreneurs in India. We are elated by the fact that India has the third largest number of start-ups globally. IESA (Indian Electronics and Semiconductor Association) applauds the government on being a facilitator to build the startup nation. With the Government's support, a startup can be built in a day which will definitely motivate many young entrepreneurs to turn ideas into action thereby increasing the jobs in India as well," says **M N Vidyashankar, President, IESA.**

## **CURRENT CHALLENGES INHERENT IN THE INITIATIVES**

There are large numbers of potential barriers in the implementation of the recent Government of India's initiative. Some hindrance in the path of implementation like fragmented policy and policy implementation, poor infrastructure and risk aversion among entrepreneur. The key challenges associated with the above two major government initiative of Make in India and Start ups are listed below:

### **The Big Picture –Challenges for ‘Make in India’**

The government launched “Make In India” initiative which aims at promoting India as an investment destination and to establish India as a global hub for manufacturing, design and innovation. The initiative aims to provide favorable environment to the business community so that they can devote their resources, efforts and energy in productive work. A number of steps have been taken by the government to improve the ease of doing business in the country. Rules and procedures have been simplified and a number of products have been taken off licensing requirements.

Under this initiative, the Government intends to provide a robust infrastructure to business through development of various facilities and institutions. Government also aims at developing industrial corridors and smart cities to provide a conducive working environment with state-of-the-art technology. Efforts are being made to provide skilled manpower through a national skill development programme. Innovation is encouraged through better management of patent and trademarks registration.

Government has opened up a number of sectors for FDI. The Policy in defence sector has been liberalized and FDI cap has been raised from 26% to 49%. 100% FDI has been allowed in defence sector for modern & state of the art technology on case to case basis. 100% FDI under automatic route has been permitted in construction, operation and maintenance in Rail Infrastructure projects. Further, liberalization norms for Insurance and Medical Devices has been done. ‘Make in India’ program represents an attitudinal shift in how India relates to investors; not as a permit-issuing authority, but as a true business partner. An Investor Facilitation Cell has been created in ‘Invest India’. A dedicated team of the Investor Facilitation Cell is there to guide and assist first-time investors.

It is time for India to focus on building competitive advantage on global scale in sectors where we have a large domestic market and certain inherent capabilities. Strategy is all about making choices. The top five priority industries are- Defence, electronics hardware, construction, health care and agro-industries. However, for India to become a manufacturing nation, it has to quickly move beyond rhetoric to create a clear strategy and favourable policy environment for manufacturing to take off. The government has chosen to quietly dismantle the sclerotic National Manufacturing Competitiveness Council (NMCC) but it needs to foster a more vibrant think tank in its place. A close dialogue and partnership between government and the private sector, both domestic and foreign, is critical. Indian companies along with Chinese, Japanese, German, American and Swedish companies are all vital partners and we must create an environment that is open and welcoming.

In many of the Indian industries, people insist for manual skill because they apprehend that adoption of advanced technology will result in redundancy of human resource, which is abundantly available in India. As such they resist the change and introduction of new technology. However, technology driven processes with minimum human intervention will guarantee manufacturing excellence. From technological point of view India is lagging behind the western world, as far as manufacturing is concerned. Experts say, India is still about a decade behind advanced countries, when it comes to usage of technology and manufacturing excellence. But this situation can be turned to our advantage. The country

can learn from the mistakes of the western world and try to adopt the best ever technology in the years to come.

Make in India necessarily involves the drive to boost the manufacturing sector. However, the investors are wary of prevalent labor laws and bureaucratic hassles in India and as such, unless conducive atmosphere is created on these fronts the investments will not come as expected and Make in India drive will not accomplish desired results. In order to make this initiative a great success, we need to be at par with the advanced world as far as usage of modern technology is concerned and we need to have more clarity, maturity and intensity on quality aspects of our products.

Creating healthy business environment will be possible only when the administrative machinery is efficient. India has been very stringent when it comes to procedural and regulatory clearances. A business-friendly environment will only be created if India can signal easier approval of projects and set up hassle-free clearance mechanism. India should also be ready to tackle elements that adversely affect competitiveness of manufacturing. To make the country a manufacturing hub the unfavorable factors must be removed. India should also be ready to give tax concessions to companies who come and set up unit in the country. India's small and medium-sized industries can play a big role in making the country take the next big leap in manufacturing. India should be more focused towards novelty and innovation for these sectors. The government has to chart out plans to give special sops and privileges to these sectors.

India must also encourage high-tech imports, research and development (R&D) to upgrade 'Make in India' give edge-to-edge competition to the Chinese counterpart's campaign. To do so, India has to be better prepared and motivated to do world class R&D. The government must ensure that it provides platform for such research and development.

India is ranked 132nd out of 185 economies in Doing Business 2013 by the World Bank. India's restrictions on foreign equity ownership are greater than the average of the countries covered by the Investing Across Sectors indicators in the South Asia region and of the BRIC (Brazil, Russian Federation, India, and China) countries. India imposes restrictions on foreign equity ownership in many sectors, and in particular in the service industries. Sectors such as railway freight transportation and forestry are dominated by public monopolies and are closed to foreign equity participation. With the exception of certain activities specified by law, foreign ownership in the agriculture sector is also not allowed. These restrictions need to be eased for making India better place for doing business.

Infrastructure tops the list of most surveys on doing business in India. In particular, chronic deficiencies in transportation and power impose prohibitive costs and lower business competitiveness. Multiple enterprise surveys have identified electricity as the biggest constraint. Further, India lags behind on every measure of transport connectivity. Though there have been considerable recent successes spurred by private participation, much needs to be done. However, introduction of UDAY scheme is a good step in this regard.

Sound macroeconomic policies are necessary to create a low-inflation, low-interest rate and high-growth environment that is essential for the country's global manufacturing

competitiveness. Given the huge size and vast diversity of the country, a diagnostic for each state may be a more prudent strategy. In any case, instead of big-bang reforms, sustained efforts in multiple directions, which cumulatively generate large effects, are required to relax these constraints so that we can realise the goal of making in India.

#### The Big Picture –Challenges for ‘Start ups’

Indian startups face its own set of challenges and some stellar opportunities. The challenges can be classified as:

**Culture**—Entrepreneurship and startups are only a recent phenomenon in the country. It is only in the last decade and half that people in the country have moved from being job seekers to job creators. Doing a startup is tough and every country sees more failures than success. More often than not an entrepreneur needs to be prepared to face failures and unprecedented hardship. However, culturally we are not groomed to fail and failure is frowned upon. Entrepreneurship thrives on celebrations and a society that fails to appreciate business failures stifles innovation and creativity even before it can start. A startup failing has to be OK as failures often teach an entrepreneur, what to do and what not to do.

**Mentoring**—Doing a startup is perilous and often a lonely journey. You may have co-founders, but you may not necessarily possess the business acumen to succeed. Having a brilliant idea is different from making that idea a business success. For a startup, it is very important to have mentors who have been through a similar process of starting or have business experience. A great mentor is often what separates success from failure by providing valuable inputs. However, there is no formal mechanism to mentor startups in the country. Every mentoring that happens is on an ad-hoc basis. A startup that has raised funds can count the investors for some form of mentoring, but honest, unbiased, good business mentors are far and few in between. For startups finding a good mentor is often an uphill task.

**Policies**—Government is the single largest enabler for the entrepreneurial ecosystem. Government’s role in ease of doing business and helping companies start is vital to ensuring success. The latest World Bank Ease of Doing Business (out of 189 economies) ranks India at an abysmal 142 where starting a business rank for the country is even lower at 158. It is uncannily difficult to start a business in India and myriad laws and regulations means it takes about 30 days to comply compared to just 9 days in OECD countries. The government’s role has so far been limited to giving out grants and loans, but without an effective, enabling environment, implementation is far off the target. In this regard it will be interesting to see the contours of the recently announced Startup Fund in this year’s budget. For startups to thrive and succeed, the government has a lot to do and understand the importance of entrepreneurship in economic development.

**Hiring**—The economy has been in a flux and along with the world economy the heady days of high growth are long gone. In an uncertain economy where one is not sure about demand, for a startup, it is particularly difficult to make correct estimates on the number of employees needed. This, however, is the minor problem where the biggest issue is about finding skilled manpower. India’s skilling need is so huge that National Skill Development Corporation (NSDC) has been mandated to skill 150 million Indians by 2022. For a startup, it is particularly difficult to attract and hire talent and skilled workers. A startup

often cannot match the salaries drawn at larger companies nor is a job at a startup seen as a steady one. This means startups face severe hiring challenges and at times have to settle for the next best option.

**Funding** – Capital and access to capital has been a perennial problem for startups. While, of late angel investors, venture capital and private equity have brought succor to some extent, a large number of startups still grapple to raise funds from institutional setup. Funding challenge is not merely limited to seed rounds, but also for vital Series A and B rounds. For a startup looking to scale, it is still very hard to raise rounds to scale as the number of investors that write larger cheques in India are very limited in number.

## **CONCLUSION**

Generally, for the effective functioning of better governance, public involvement is the prime concern. It includes three pillars such as public access to information, public participation in decision-making processes and public access to judicial and administrative redress often termed as ‘access to justice’. Good governance is putting people at the centre of development process. The citizens are ready to pay the price for good services offered by the state, but what is required is transparent, accountable and intelligible governance system absolutely free from bias and prejudices. In the present era when India is progressively moving towards development and prosperity, there is a need to reformulate our national strategy to accord primacy to the Gandhian principle of ‘Antodaya’ to restore good governance in the country. In such circumstance, when the nation/state machineries become more efficient and accountable, the citizens can enjoy higher per capita income, wide spread literacy, adequate health facilities with longer average life.

After all, the good governance in the country can be succeeded when the government understand view points of citizens and gather feedback, get people’s ideas and their contribution through the tasks and implement the best ideas and practices in achieving the goal of ‘better Governance’.

## **REFERENCES**

- [1] Munshi, Surendra, “*Concern for Good Governance in Comparative Perspective*”, in Munshi, Surendra and Biju Paul Abraham (eds.), *Good Governance, Democratic Societies and Globalization*, New Delhi, Sage Publications, 2004.
- [2] United Nations Development Programme, *Governance for sustainable human development*, UNDP policy document, New York, 1997.
- [3] WORLD BANK (1997). World Development Report, 1997: *The State in a Changing World*, Washington, D.C., World Bank.  
<http://indianexpress.com/article/technology/tech-news-technology/start-up-india-what-india-inc-has-to-say-about-modis-pet-scheme/>  
<https://tejas.iimb.ac.in/articles/MAKE%20IN%20INDIA.pdf>



# Will Automation and Artificial Intelligence Disrupt the Future Workplace?

JAYANTA CHAKRABORTI<sup>1</sup> AND SUSHIL MAURYA<sup>2</sup>

## Abstract

*The Workplace has gone through a transformation over the last century from a manual driven process to a mechanized process to an automated process. Today the buzzword in Industrial Workplace is Automation and Artificial Intelligence. Companies are deploying robots, chat bots and humanoids to get tasks accomplished that were hitherto being done by human beings. TV Mohandas Pai, Chairman of Manipal Global and ex-CFO of Infosys, has predicted that 2,25,000 jobs will be lost in next one decade due to automation.*

*Companies are currently using Cognitive Computing, Machine Learning and Deep Learning to maximize their output and return-on-investment (ROI) from the Workplace. Cognitive Computing is being used to handle complex, ambiguous situations and enable more “human-like” interactions with software. Here, human thought processes are simulated through data mining, intelligence, automation and natural language processing. Machine learning is used to automate the building of systems by learning from data. It identifies patterns and predicts future results with minimal human intervention. Deep Learning is where Machine Learning meets Big Data and Analytics. Deep Learning uses Neural Networks to structure a computer like the human brain — complete with neuron-like nodes connected together.*

*Will Automation and Artificial Intelligence disrupt the Future Workplace? How will the Workplace of Future look like? What are the skill-sets that employees of tomorrow need to acquire to face the challenges of tomorrow? How will Industrial Robots and Human Workers complement each other? This research paper will seek to understand how Artificial Intelligence and Business Analytics will reshape Future Workplace.*

**Keywords:** Automation, Artificial Intelligence, Cognitive Computing, Machine Learning, Deep Learning

## THE PROBLEM STATEMENT

The quest for creating a great workplace that boosts productivity has been a challenge for social scientists and corporate leaders for the last hundred years. The experts have tried several approaches like creating a conducive work environment in earlier days and the

<sup>1</sup> HOD, School of Management Studies, ICFAI University Agartala  
E-mail: jayantachakraborty@iutripura.edu.in

<sup>2</sup> Associate Professor, School of Management Studies, Mangalmai Institute of Management & Technology, Greater Noida (UP)  
E-mail: maurya.k.sushil@gmail.com

use of AI (Artificial Intelligence) and IoT (Internet of Things) in recent times to create the perfect workplace.

The objective of this research paper is to understand whether Automation and Artificial Intelligence (AI) will disrupt the future workplace and what would be the positive and negative outcomes of the same.

## **RESEARCH METHODOLOGY**

We have done a descriptive research using secondary data. A sample study was done on 50 International Companies and 50 Indian Companies to understand the trends, patterns and insights on what role Automation and AI (Artificial Intelligence) is playing to create the perfect workplace. The Hypothesis Testing was validated using Factor Analysis. The information used is secondary data collected from journals, magazines, newspaper articles and authentic research papers.

## **INTRODUCTION**

In the late 1920 and early 1930, a group of Scientists at Western Electric's factory at Hawthorne, USA, did a study to understand what factors influenced productivity at workplace. The experiments were conducted under the supervision of Elton Mayo, who eventually became a Professor at Harvard University. The experiments comprised of making workers work in two groups. In one group, the lighting was improved dramatically while the other group's lighting was kept unchanged. The researchers were surprised to find that the productivity of the more highly illuminated workers increased much more than that of the control group.

The Scientists did further tests by changing the other parameters like working hours, rest breaks and so on, and in all cases their productivity improved when a change was made. Indeed, their productivity even improved when the lights were dimmed again. By the time everything had been returned to the way it was before the changes had begun, productivity at the factory was at its highest level. Absenteeism had plummeted.

After thoroughly investigating and analyzing the findings, the Scientists concluded that it was not the changes in physical conditions that were affecting the workers' productivity. Rather, it was the fact that someone was actually concerned about their workplace, which gave the impetus to perform better.

Since then, numerous interventions have been done to design a workplace that will provide enhanced productivity. Infosys created a college campus like environment replete with cafeteria, gym, swimming pool, movie theatres, ATM and shopping malls. Google has created a workplace that features Lego stations, Ping-Pong tables, and a secret ladder that runs between floors. A key characteristic of the Google Campus that makes it so special is its playfulness and overall fun feeling. Employees at Googleplex are also treated to free healthy snacks like dried fruit, energy bars, and coconut water.

However, despite all these interventions, the challenges of productivity, attrition and loyalty to the organization has increased by the day. The attrition rate of Infosys went up to 21% in 2016. TCS has an attrition rate of 16%, Wipro has 16.5% and HCL has 18.6%. The companies have offered ESOP (Employee Stock Option Plan), Flexible Working Hours

and several key benefits for better work life balance but the results have been far from being encouraging.

In sheer exasperation, the corporates have now moved towards automation and artificial intelligence to reduce dependency on human workforce. We already have ATM (Automated Teller Machines) that dispense cash, robots that work in assembly line manufacturing and chat bots that answer queries to perform customer relationship management (CRM). HDFC Life, one of India’s leading private life insurance companies, announced the launch of India’s first life insurance chatbot in collaboration with Haptik, India’s largest chatbot platform. The chatbot will act as a financial guide to help users choose the most suitable life insurance plans and solutions.

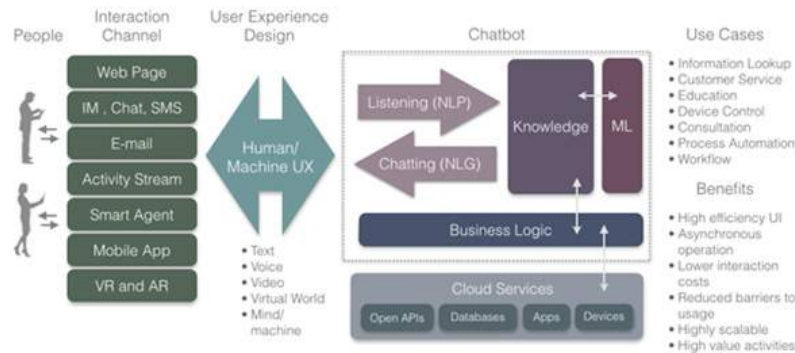

Figure 1: How Chat Bots are Adding Value to the Workplace

The Chinese Mobile Phone manufacturing company, Foxconn, who is mainly a third party manufacturer of Apples i-Phones and Samsung, has gone for automation to replace human workers. In Foxconn’s Zhengzhou factory, its largest and most capable plant that produces 500,000 i-Phones a day, it has reduced the size of workforce from 1,10,000 to 50,000. The company has reduced 60,000 factory workers with robots.

Cognitive Analytics, Deep Learning and Machine Learning

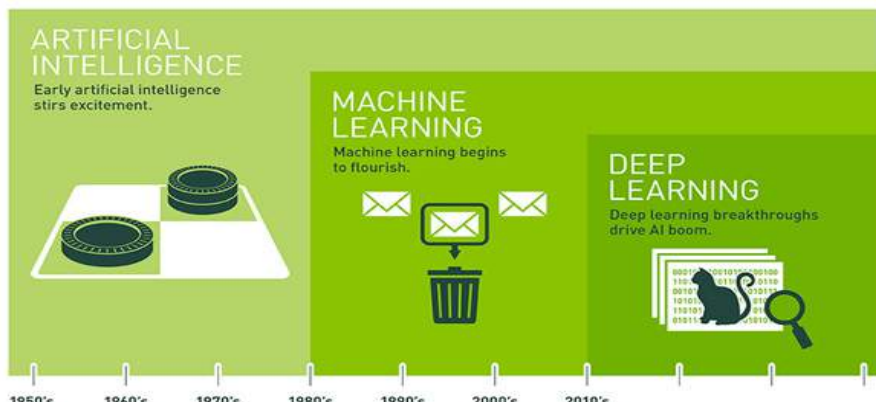

Figure 2: Advent of Artificial Intelligence (AI), Deep Learning and Machine Learning

What are the technologies that are contributing to the rise of Automation and Artificial Intelligence? Although there are several key variables and affected factors, we have identified three key variables through Factor Analysis of available data. The three key variables are Cognitive Analytics, Deep Learning and Machine Learning.

Cognitive Analytics is a field of analytics that tries to mimic the human brain by drawing inferences from existing data and patterns, drawing conclusions based on existing knowledge bases and then inserting this back into the knowledge base for future inferences. Cognitive Computing is being used to handle complex, ambiguous situations and enable more “human-like” interactions with software. Here, human thought processes are simulated through data mining, intelligence, automation and natural language processing.

Machine learning is the science of getting computers to act without being explicitly programmed. Machine learning is used to automate the building of systems by learning from data. It identifies patterns and predicts future results with minimal human intervention. In the past decade, machine learning has given us self-driving cars, practical speech recognition, effective web search, and a vastly improved understanding of the human genome. As per data given by SAS, Machine learning is now being used by Financial Services, Healthcare, Oil & Gas, Logistic and Government companies.

Deep Learning is where Machine Learning meets Big Data and Analytics. Deep Learning uses Neural Networks to structure a computer like the human brain — complete with neuron-like nodes connected together. Deep Learning represents the true bleeding edge of Machine Learning. Today, image recognition by machines trained via deep learning in some scenarios is better than humans, like identifying indicators for cancer in blood and tumors in MRI scans.

IBM recently came out with their disruptive technology called Watson, which is attempting to replicate the human brain through ANN (Artificial Neural Networks). Watson is revolutionizing the way decisions are made across industries by uncovering patterns in new and intelligent ways. Watson uses natural language processing and machine learning, among other artificial intelligence technologies, to reveal insights from large amounts of unstructured data. It employs reasoning strategies that evolve to become more sophisticated and handle increasingly complex problems.

IBM Watson, the world’s broadest platform of cognitive technologies, is effectively combining an understanding of how humans communicate – through metaphors, idioms and natural language – with machine capabilities such as deep learning and large-scale mathematics, to provide useful insights from vast amounts of unstructured data. Watson can analyse and understand natural language such as tweets, text, articles, studies and reports and at the same time, make contextual sense out of videos and images.

Watson’s cognitive computing capabilities address the needs of industries ranging from healthcare and scientific research to customer service, retail and financial services. Watson is at work scaling human expertise and drawing insights from data in both established businesses that need design innovative solutions for recurring issues, and with start-ups that need to crystallize their creativity into real businesses.

These developments are now acting as a threat as well as opportunity. The fear is that there will be massive job losses due to Automation and Artificial Intelligence. TV

Mohandas Pai, Chairman of Manipal Global and ex-CFO of Infosys, has predicted that 2,25,000 jobs will be lost in next one decade due to automation (31st July, 2016, Economic Times).

The opportunity lies in improved productivity and shifting of the labor to high quality jobs with better pay. Automation and Artificial Intelligence can also improve quality or increased predictability of quality, improved robustness (consistency) of processes or product, increased consistency of output and reduced direct human labor costs and expenses.

### **THE INFERENCES**

Our exhaustive study on the effect of Automation and Artificial Intelligence indicates that the workplace will radically change both in features and in constituents. The future workplace will comprise of both types of workforce – humans and robots – both in proportionate quantum to the nature of work with a viable synergy between themselves to achieve the organizational goals.

Will there be job losses? The answer is yes. Which jobs are most vulnerable? Our study shows that most workers in transport and logistics (such as taxi and delivery drivers) and office support (such as receptionists and security guards) are likely to be substituted by IoT (Internet of Things), and that many workers in sales and services (such as cashiers, counter and rental clerks, telemarketers and accountants) also faced a high risk of getting replaced by Chat Bots. The recent developments in machine learning will put a substantial share of employment, across a wide range of occupations, at risk in the near future.

**Table 1:** Probability of Job Loss due to Automation

<i>Job</i>	<i>Probability</i>
Recreational Therapists	0.003
Dentists	0.004
Athletic Trainers	0.007
Clergy	0.008
Chemical Engineers	0.02
Editors	0.06
Firefighters	0.17
Actors	0.37
Health Technologists	0.40
Economists	0.43
Commercial Pilots	0.55
Machinists	0.65
Word Processors and Typists	0.81
Real Estate Sales Agents	0.86
Technical Writers	0.89
Retail Salespeople	0.92
Accountants and Auditors	0.96
Telemarketers	0.99

*Source:* Economist.com

There is also a threat of job polarization, where middle-skill jobs (such as those in manufacturing) are declining but both low-skill and high-skill jobs are expanding. The stagnation of median wages in many Western countries is evidence that automation is already having an effect. Figures published by the Federal Reserve Bank of St Louis show that in America, employment in non-routine cognitive and non-routine manual jobs has grown steadily since the 1980s, whereas employment in routine jobs has been broadly flat. As more jobs are automated, this trend seems likely to continue.

The positive and negative outcomes of Automation and Artificial Intelligence, as inferred from our study are:

### **Positive Outcomes**

- I. Reduction in production time
- II. Increase in accuracy and repeatability
- III. Less human error
- IV. Less employee costs
- V. Increased safety
- VI. Higher volume production
- VII. Reduced Production Cost
- VIII. Decrease in Part Cycle Time
- IX. Improved Quality and Reliability
- X. Better Floor Space Utilization
- XI. Reduce Waste
- XI. Competitive Edge

### **NEGATIVE OUTCOMES**

- I. Less versatility
- II. More pollution
- III. Large initial investment
- IV. Increase in unemployment
- V. Unpredictable costs

### **Conclusion and Recommendations**

In the long term, robots are cheaper than human labor. However, the initial investment can be costly. It's also difficult, expensive, and time consuming to program robots to perform multiple tasks, or to reprogram a robot to perform tasks outside its original function. That is why, in labor markets like India and China, human workers have thus far been cheaper than robots.

Former McDonald's chief executive Ed Rensi recently told the US's Fox Business that a minimum-wage increase to \$15 an hour would make companies consider robot workers. "It's cheaper to buy a \$35,000 robotic arm than it is to hire an employee who is inefficient, making \$15 an hour bagging French fries.

Robots will help companies and brands move manufacturing closer to markets. Customer needs and increasing scale will decelerate the global search for cheap labor. With scale the prices of robots come down. A Study done by McKinsey projects that growth in the global installed base of advanced robotics will accelerate from around 2% to 3% annually today to around 10% annually during the next decade.

While automation has become a resource for remaining competitive in the manufacturing industry, there are definitely some factors to be considered in order to be competitive and to get a return on the investment. Depending on the operations, automation may or may not be a good fit. If it is a small operation with low production quantities, the initial investment of purchasing an automated machine would not be economical. On the other hand, if the operation has a larger facility with many employees on the shop floor two fabricate medium to large runs, automated machines would be better suited.

## REFERENCES

- [1] Chui, Michael; Manyika, James; Miremadi, Mehdi (2014) ; “*Four fundamentals of Workplace Automation*”, McKinsey Quarterly, November 2015.
- [2] Autor, David H., “*Why are there so many Jobs? The history and future of Workplace Automation*”, The Journal of Economic Perspectives, Volume 29, Number 3, Summer 2015, pp 3-30.
- [3] Smith, Michael J, Carayon Pascale; “*New Technology, Automation and Work Organization*”, International Journal of Human Factors in Manufacturing, Volume 5, Issue 1, December 1995, Pages 99-116.
- [4] Pyle, Dorian; Jose, Cristina San; “*An executive’s guide to Machine Learning*”, McKinsey Quarterly, June 2015.
- [5] Chui, Michael; Manyika, James; Miremadi, Mehdi (2016) ; “*Where machines could replace humans – and where they can’t (yet)*”, McKinsey Quarterly, November 2016
- [5] Economic Times, “*HDFC Life in partnership with Haptik brings first of its kind life insurance chatbot in India*”, March 02, 2017.
- [6] Wakefield, Jane, “*Foxconn replaces 60,000 factory workers with robots*”, 25 May 2016, BBC News.
- [7] Economic Times, “*Automation to replace lakhs of entry, mid-level IT execs: TV Mohandas Pai*”, July 31<sup>st</sup>, 2016.
- [8] Shah, Rawn; “*The Workplace of the future is still the Office*”, Forbes 9<sup>th</sup> September, 2014.
- [9] Autor, David H., “*The Shifts – Great and Small – in Workplace Automation*” , MIT Sloan Review, 15<sup>th</sup> August, 2016.

# Digital India

ANTIKA BHARGAVA<sup>1</sup>

## Abstract

*Digital India means transforming India into a digitally empowered knowledge economy. We live in today that is the digital world which is the outcome of several innovations and technology advances. This world provides better future to everyone. At present, every nation wants to be fully digitalized that will empower society in a better manner. In India this step is to be taken by our Prime Minister Sh. Narendra Modi for the purpose of to integrate the Government Departments and the people of India in digitalized. This programme aims at ensuring that the Government services are made available to citizens electronically by reducing paper work and time consuming. This paper attempts to highlight the different challenges faced by the Digital India Programme. It describes the different opportunities of the programme for the people of the country. The main objective of this concept is that everyone has information, everyone should be educated, and everyone should be more transparent and participative.*

**Keywords:** *Electronic India, Digitalization, Growth, Economy.*

The main objectives of this paper are as follows:

1. Every people of India have information about the digitalization.
2. Every people of India should educate.
3. Leadership structure
4. Every people should be updated with technology world.



## INTRODUCTION

Through the digital India programme country has achieved their objectives of progress and now India count in developing countries. From smart phones to lightning-fast laptops to GPS devices, it's hard to imagine life without technology. In the twenty-first century, one of the most important technologies is the power of the digitization. The project aims to connect the 2.5 lakh villages across India through broadband highways, public internet

---

<sup>1</sup> Management Faculty Tecnia Institute of Advance Studies, GGSIPU  
E-mail: antikaaradhya@gmail.com



access, universal access to mobile connectivity, 10 13 e-governance, e-kranti, information for all, early harvest programmes, and IT for jobs—known as the nine pillars of Digital India. The cost of this project is estimated at Rs 1, 13,000crore. The Digital India Advisory Group will be chaired by the Cabinet Secretary and monitored by the Prime Minister and his office. For the Digital India initiative, the original design and programme content of the e-governance project have been distinctly. Main vision of Digital India to transform India into a digital economy with participation from citizens, businesses and promises to make India an important investment destination. Digital India provides the e-power platform for more creative and service-oriented business models that create employment opportunities. High speed network will aid adequate infrastructure for online education platforms through smart and virtual classrooms. Thorough this programme in India government provide practical classes, training program me etc. Digital India is like this initiative will ensure that all government services and information are available anywhere, anytime, on any device that are user friendly and secured. Digital India like a umbrella in which the every citizen has blessing to bring a global platform for participation from the businesses.



### **PARTICIPATION IN DIGITAL & FINANCIAL SPACE THROUGH MOBILES & BANKING**

If we could go back in time and halt over a decade ago, we would realize that mobile phones and tablets belonged to few fortunate ones residing in urban India; in villages and small towns the old style landline phone with a shrill ring was more common. There has been a mobile revolution in last few years and through competitive pricing, soaring technology and advanced features, it has now become a necessity and a must-have item of every household. With the introduction of cheap internet data plans, the whole India seems to be captured on the mobile screen, be it online shopping, ticket booking, online payments or connecting to different services by installing their applications. Today as more than 80% internet users of India access internet through their mobile devices giving a huge opportunity to the government to spread e-governance in general and digital-cum-financial inclusion in particular. In the mobile space, Deity has launched Mobile Seva, a revolutionary whole-of-government mobile governance initiative, enabling government departments and agencies across the nation to deliver public services to citizens and businesses through mobile devices across various mobile-based channels such as SMS, USSD, mobile apps, and voice/ IVRS. In the financial space, Deity has collaborated with NSDL Database Management Limited (NDML), a wholly owned subsidiary of National

Securities Depository Limited (NSDL), for providing PayGov, a centralized platform for facilitating all government departments and services to collect online payments from citizens for public services. PayGov offers an end-to-end transactional experience for citizens who can opt from various payment options such as Net Banking (70+ banks), debit cards, credit cards, cash cards/ prepaid cards/ wallets, and NEFT/ RTGS, etc. Agriculture, Health. The 'Pradhan Mantri Jan-Dhan Yojana' is a great initiative taken under digital India Programme to ensure financial inclusion

**“Governance Should be Aimed at Digital Government In Fact Why Not Mobile Governance. We Need To Focus On Digital India To Ease Business Through Easy Governance. With A Digital India, There Will Be Easy Governance.”**

### **Projects under Digital India Programme**

1. Under digital India programme the Government of India has undertaken some 7 projects .
2. These projects are as follows:
  - (a) Digital locker system of the digital India programme will help citizens to digitally store their important documents like pan card, passport, mark sheets and degree certificates. It will help to minimize the usage of physical documents and will provide secure access to Government issued documents.
  - (b) Another key projects under Digital India programme is My gov.in which has been implemented as platform for citizen engagement in governance, through a “Discuss, Do and Disseminate” approach.
  - (c) Swachh Bharat Mission Mobile App is one of the projects of Digital India programme which will help the people and the government organization for achieving the goal of Swachh Bharat Mission.
  - (d) e- Sign framework would allow citizens to digitally sign a document online using Aadhar Authentication.
  - (e) Online registration system under the e- Hospital application has been introduced. This application provides important services such as online registration, payment of fees and appointment, online diagnostic reports, enquiring availability of blood online etc.
  - (f) National scholarship portal which will put an end to elongated scholarship process.
  - (g) The Government of India has undertaken an initiative namely Bharat Net, a high speed digital highway to connect all 2.5 gram panchayats of the country. This would be the world’s largest rural.

### **Challenges of Digital India**

As the is new programme, it is will face many challenges. Some of the challenges which may create problem in its implementation are as follows

- (a) India is a diversified country in terms of culture. Each state has its own specific language, customs, food habits, laws and traditions. Digital India program aims

to integrate the whole country digitally. Complete integration that is integration of technology and language is one of the main challenges the mission would face in its implementation.

- (b) There are different internet protocols in different states depending on what kind of hardware and software they implement.
- (c) Digital India aims to transform the country into a digitally empowered knowledge economy. It is not an easy task. It needs coordination and cooperation of all the government Departments. Without the smooth teamwork between the departments the mission would never be implemented to its full strength.
- (d) Public internet access is one of the pillars of Digital India programme. But in India, poverty and illiteracy stands as major obstacles in internet access. High illiteracy rate act as a major road block in expanding the reach of internet.
- (e) We live in a world where internet and cyber-crime are inseparable enemies. The entire architecture should be designed in such a way that there is proper authentication done of all the documents put online by citizens and it is available to the right users at any time they want with the right authentication. In order to ensure the cyber security the country should have privacy norms.

## **PILLARS OF DIGITAL INDIA**

### **The Road to Smart Governance**

*Broadband Highways:* The first step is to provide high speed broadband highways through fiber optics that connect all the remote areas, government departments, universities, R&D etc. Web based portals and Mobile apps will be developed to access online information while on the move.

*Universal Mobile Access:* In the coming years, network technologies like 3G, 4G and upcoming 5G will storm the speed. Government is specially preparing to connect unconnected areas and speedy use of these technologies. General public will access the online government services with the help of handheld devices. Nation is ready to be well-connected, efficient, and more productive in every aspect.

*Public Internet Access:* Virtuous technologies that support cost containment, collaboration, security, services-on-the-go, social-connect, and in-built intelligence that deliver remote access to any information or service available across the domain. This change will open new doors of e-services to every citizen. iv. e-Governance: This governance will transform every manual work into fully automation system. It will revolutionize the system in the following ways

*E-Kranti:* This kranti will fully focus on digital knowledge program where education, health, farming, rights, financial and many more services will be delivered on a very high bandwidth. Physical boundaries no longer are a limitation when almost everyone and everything is a digital handshake away. vi. Information for All: Websites and mobile apps will convey data and realistic participation and through social media. Everything is connected through virtual networks. Swift work flow and no delays due to wait in queues. vii. *Electronics Manufacturing:* This milestone will create a huge base for electronics

manufacturing in india with the aid of digital technologies and skills. The empowerment of manufacturing through the Internet of Things will enable intelligent workshops that demonstrate data driven operational excellence and decentralized production control systems within and beyond the physical factory walls.

## CONCLUSION

Government will do well to take into account the recommendation of the council on Digital Government strategies as entrusted in the OECD 2013 Ministerial Council Meeting while considering the agenda on “ trust in Government: evidence, policies and decision making” at this stage of implementation of Digital India programme The elements of the Digital India programme accommodate all of the recommendation of the OECD referred above. So in the theoretical framework, the Digital India programme will be a state of the art network. How far the strategy would yield result in meeting the desired objectives would largely depend on factors which are outside the realm of technologies and tools for digitization. These are rooted in the organization maturity and commitment of the systems within the government and also dependent on public support, overcoming the shackles of historical and cultural traits and the installed wisdom which feels threatened with the transformation that will sweep them off their feet. For successful implementation of Digital India Programme involves lot of hindrances but in the present global context there is no second thought. Therefore it is highly expected to expedite the initiation of the digital India Programme.

## REFERENCES

- [1] <http://ierj.in/journal/index.php/ierj/article/view/541/512>
- [2] [https://www.worldwidejournals.com/indian-journal-of-applied-research-\(IJAR\)/file.php?val=October\\_2015\\_1444211851\\_\\_223.pdf](https://www.worldwidejournals.com/indian-journal-of-applied-research-(IJAR)/file.php?val=October_2015_1444211851__223.pdf)
- [3] M.M.K Sardana(2012),” Vision of Digital india challenges ahead for political establishment DN2012/09,ISID.
- [4] Usha Rani Das, challenges of Digital India some heads –up of NarendraModi, Business insider India.
- [5] Digital India power to empower, available at [www.nextgenias.com/2015/09/eassydigital-india-programme-upsc-20](http://www.nextgenias.com/2015/09/eassydigital-india-programme-upsc-20).
- [6] E-governance: Reforming government through technology.
- [7] E-kranti: Electronic delivery of services. 79 International

# E-Commerce: Tool for Empowering Women

RAGHVENDRA SINGH KALCHURI<sup>1</sup> AND SEEMA CHHABRA<sup>2</sup>

## Abstract

*During past decades, e-commerce has blossomed into multi – billion dollar industry with more than 50% accounting for online purchases by women. As a result, this has given rise to e-commerce business run exclusively for women that validates there is a huge potential for women to play in e-commerce space. India being a strong follower of this, the paper is an insight to bring conceptual framework for empowering women by transforming their role from home maker to employed workforce through tool of e-commerce. This paper may contribute to academicians, researchers to assess the role of women engaged in e-commerce business.*

**Keywords:** e-Commerce, e-Business, Role of Women

## INTRODUCTION

E-commerce sector is booming all around the globe with the role of women significant for economic growth of the country. As women in business play a pivotal role in business world and e-commerce business is the most valuable source of work-home life balance where women can learn and work from home. Therefore, the opportunities and constraints for women in e-commerce business are key areas to boost the country's economic growth. E-commerce as a whole includes cycle from production, procurement, distribution, sales fulfillment. This includes women entrepreneurs owing to small business sale in e-commerce bringing new information systems and open new e-commerce channels for women community.

## WOMEN AND E-COMMERCE

According to Meena Seth, in business world, “The real problem is not whether machines think but whether men do” as originally stated by B F skinner, social philosopher.

During last decade, women entrepreneurs have benefited from using the new technologies in a large number of areas, such as getting access to valuable business information, finding new (export) markets, marketing their products and services over the Internet, securing large orders through networking with community members, and generally cutting costs through more efficient business.

---

<sup>1</sup> Research Scholar, Bundelkhand University, Jhansi (UP)  
E-mail: rskalchuri@gmail.com

<sup>2</sup> Associate Professor, Axis Colleges, Kanpur (UP)  
E-mail: khushirupal@gmail.com

According to Saurav Adhikari (1234, BW, 26 July-8 August 2016, women in technology is becoming a valuable part for virtually every organisation in global economy. It is also believed that m-commerce may contribute up to 70% of total e-commerce revenues in near future.

Even in e-commerce, women entrepreneurs are showing a rise in Islamic countries too. *Hizaab* and veil is no longer a barrier in their entrepreneurial skills and work from home helps them to have congenial relations and supportive environment to their family members too.

Even with the booms of e-commerce, women entrepreneurs have boosted the growth of e-commerce business women in Islamic countries like Zakarta and Indonesia. According to an estimate 30% to 50% rise of online of business in India is from tier 2 and tier 3 cities. Challenges for women in e-commerce industry:

Challenges for start-ups are customer acquisition, finding proper niche, raising funds, reliable logistics and supply chain, effective customer service etc.

According to World Islamic economic forum in 2016 Mrs. Riski Hapaski from Indonesia, founder and owner of Kolesiikku.com from republic of Indonesia owning e-commerce business of Indonesia home-made accessories brought the challenges of logistics, distribution and shipping is a challenge. It costs 10 times. Value creation in the bus and promotion of site is very important for e-commerce women entrepreneurs. So decentralizing growth, empowering future business and meeting the training needs for young women entrepreneurs to combat the issues of fraud, payment platforms and buyers online. The job satisfaction that women achieve is entertaining rather than working at stressful and home away workplace. E-bay is giving training equipped with skills for online business. They empower more women to sell their product on market place by providing superior global market place

Since e-commerce women are getting freedom from work at home due to sudden rise in technology. Minimum investment, comfortable work from environment, global reach are the booms for women in e-commerce business Classifieds, real estate, healthcare, home furnishing, jewellery, handicrafts and fashion apparel are the preferred sectors for e-commerce business women entrepreneurs.

## **POTENTIAL FOR WOMEN IN E-COMMERCE MARKET**

According to Ravi Kapoor, former CEO, IBEF during the past decades, India has shown a dramatic shift towards e-commerce industry, thanks to “Cash on delivery” option. Flipkart, Snapdeal, Myntra and Jabong are domestic e-commerce players. Global players like Amazon and E-bay are increasing their market share.

According to a survey by e-marketer in 2016, world-wide retail e-commerce sales will top \$ 27 Trillion in 2020 as compared to \$23 trillion in 2017. It includes sales from e-commerce retailers and transactions that occur over C2C platforms such as e-bay and other business auction sites and sales by motor vehicle and past dealers and gas states. E-marketer expects retail commerce sales will increase to \$4.058 trillion in 2020 making up 14.6% of retail spending in 2016. Expanding middle class, greater mobile and internet

penetration, growing competition of e-commerce players and logistics and infrastructure will boost e-commerce growth in the region.

India is expected to have the second target digital population in the world with 1 billion users by 2030 by increasing mobile penetration; e-commerce business is biggest game player in Indian economy. According to survey report by Google and forester consulting, the number of online shoppers will be over 50 million, new players emerging from tier 2 and tier 3 cities. Prompt delivery, omni channel retailing to enhance sales and reach target audience, logistics improvement through India post (postal network of 1.55 lakh post offices, rise of private players, shopping location are latest buzzwords in e commerce industry

### **GOVERNMENT AND WOMEN EMPOWERMENT THROUGH E-COMMERCE**

According to Arun Jaitley, cashless economy, e-wallets will raise GDP growth. E-commerce companies can make most of the tax relief, will be able to allocate these funds in adopting new technologies by the skilled resources giving rise to new challenges. This help e-commerce companies to create more job opportunities and strengthen their core teams. The tax reduction for companies with turnover up to Rupees fifty Lakh to twenty five percent from earlier 30% will be beneficial to 6.67 lakh companies in India. This will relieve e-commerce companies in India. The government plays an instrumental role in encouraging e-commerce growth through concrete practicable measures such as creating a favorable policy environment for e-commerce. Development of e-commerce by Government can be boosted by favorable Government policy issues, Information network to be easy and inexpensive, legal recognition of e commerce transaction, Practices to prevent fraud and the customers right to prevent intellectual property and legal protection against cracking.

Regulatory bodies and ICT has played a very important contribution in terms of geographical information system and supports trade to business component which is a bigger component of e commerce. Regional national and international women empowerment are forming an association to increase their access to technology and business cultures in foreign markets. Various measures by Government will boost growth of e commerce women entrepreneurs.

1. E-procurement can include ‘agency enablement’ programs, ‘supplier enablement’ programs, and e-procurement information systems.
2. Counter clearance-one can expect more predictable and more precise information on clearing time and delivery shipments, and increased legitimate revenues.
3. Tax Administration – It includes processing and transmission of tax return information, online issuances of tax clearances, permits, and licenses, and an electronic process registration of businesses and new tax payers among others.
4. SME development encouraged to develop “SME desks” that will address the specific needs of SMEs. In particular, steps should be taken to:
  - provide incentives to individuals to become entrepreneurs by lowering borrowing rates

- provide incentives to SMEs that intend to use ecommerce in their business operations
  - broaden credit extension facilities to SMEs in order for them to use ICT and ecommerce;
  - Offer discounts on business solution software packages and software licenses. Moreover, big businesses and corporations should be encouraged to transfer technology to SMEs by offering them free training in ICT and e-commerce.
5. E-government and awareness campaign may include “Tele-centers” or electronic community centers that would serve as a community-shared access and connectivity platform especially in the rural areas (e.g., an electronic agro information center which provides market information to farmers in rural areas)
  6. Strengthening consumer protection Certification Authority, which verifies seller and buyer identities, examines transactions and security procedures, and issues digital certificates to those who are able to meet the set security standards and protection of intellectual property.

#### **NOTEWORTHY CONTRIBUTIONS OF WOMEN IN E-COMMERCE INDUSTRY**

The zeal and dedication of every successful women entrepreneur no matter what obstacle or hurdle came provides an edge to male counterparts. No matter what the field, women entrepreneurs are really showing the path for millions other in the country. The stories and achievements are really inspiring which every individual should know about it. Whether it is technology, retail, social enterprise sector, adventure, women entrepreneurs are evolving as a force in every sector. Women are stepping out from their comfort zones for e-commerce business in the field of investor, innovator, analysts and journalists. Some of the top women entrepreneurs in India are Swati Bhargava, Neeru Sharma, Richa Kar, Suchi Mukherjee, Upasna Taku, Bhavna Agarwal, Pearl Uppal; Anisha Singh, Vani Kola and Sabina Chopra.

Here are 10 e-commerce business entrepreneurs in Indian ecosystem who are as follows:

- Swati Bhargava-CEO and cofounder of Cash Karo which deals with the concept of Cash back and affiliate marketing, the biggest challenge she faced was to give training in India for Cash Back concept.
- Neeru Sharma is Cofounder & Director in Corporate team of Infibeam an Indian online shopping portal. Finding the correct talent for here venture she overcame as an entrepreneur.
- Suchi Mukherjee is CEO of online shopping portal Limeroad.com which gives an option where users can create their own scrapbook of looks and ideas. The biggest challenge for her was to retain the right talent and cross cultural training in her business.
- Upasna Taku is CEO and cofounder of Zaakpay.com, a mobile app payment SDK and web payment solutions to e-commerce companies in India.
- Peral Uppal – an Internet startup and growthspecialist, an entrepreneur and investor. She initiated India based e-commerce marketplace Fashionandyou.com.



- There are many more successful women entrepreneurs namely Sabina chopra, Anisha Singh, Vani kola, Jaya Jha, Kanika Tekriwal, Kavitha Iyer, Lisa S Rao, Neeru Sharma, Neetu Bhatia, Neha Behani, Neha Motwani, Pallavi Gupta and Pankhuri Shrivastava.

## **CONCLUSION AND SUGGESTIONS**

The high priority potential sectors for e-commerce business women are retail, consulting services, accounting/law, and fashion industry. Marketing and customer service is the most neglected area of support services for women. High level training, gender analysis, planning, designing, implementation, monitoring, assessment and paying attention to the effect in women's life are key areas to focus on.

Start up products, training programs, workshops are main buzzwords of e-commerce business. Online seminars, continuous programs to motivate, encourage and cooperation with women entrepreneurs is required in the same lines of Flipkart, Amazon and Snapdeal. According to B. R Ambedkar "I measure the progress of community by degree of progress the woman has achieved." Due to the qualities of true power, capability and innovation they are emerging as successful women entrepreneurs too. Future of India's economic growth lies in the hands of women.

Women in business have more to give than to take as compared to men. Women have more qualities in business like stability, equality and style in business relation as compared to men. The rise in Indian women empowerment in e-commerce envisages that women entrepreneurs are emerging as smart and innovative business, women their share in socioeconomic sector is remarkable.

## **REFERENCES**

- [1] Kumbhar, Vijay. (2013). Some critical issues of women entrepreneurship in rural India. European Academic research, VOL. I, issue 2.
- [2] Chander, Subash. (2013). Study of financial problems of women Entrepreneurs, International Journal of Social Science & Interdisciplinary Research, Vol.2 (4). Electronic Commerce World Journal homepage.
- [3] Jayen, K.Thaker. (2013). Obstacles faced by women Entrepreneurs in India.
- [4] <http://www.ecworld.utexas.edu>,
- [5] [http://en.wikibooks.org/wiki/E-Commerce\\_and\\_EBusiness/](http://en.wikibooks.org/wiki/E-Commerce_and_EBusiness/)
- [6] E-Commerce\_in\_Developing\_Countries,
- [7] [www.emarketer.com](http://www.emarketer.com)

# Corporate Social Responsibility and Sustainable Development

SANJANA TEWARI<sup>1</sup>

## Abstract

*According to late Prime Minister Lal Bahadur Shastri, “Too often the community views the businessmen’s aims as selfish gain rather than advancement of the general welfare. That impression can be removed only if business is fully alive to its social responsibilities and helps our society to function in harmony as one organic whole.” The meaning of Corporate Social Responsibility has been changing from the days of Industrial Revolution. Corporate houses right from the inception of human race have been regarded as important constructive partners in their operating communities. Though they have been playing a vital role in creating employment, wealth, products and services, still they have a pressure to play a pivotal role in social issues involving stakeholders. Corporates now not only exist to earn profits but also strive to satisfy various societal needs.*

*Keith Davis defines Social Responsibility as “Social Responsibility refers to the businessman’s decisions and actions taken for reasons partially beyond the firm’s direct economic and technical interest.” Corporate Social Responsibility refers to the sense of obligation that the companies have, in order to build certain social criteria and manage the business activities by taking strategic decisions. Businesses can succeed only if they maintain good relationships with all their stakeholders and strengthen them by fulfilling their obligations towards the society.*

*This paper focuses on the concept of Corporate Social Responsibility and the current scenario. It emphasises on the interrelationship between the Corporate Social Responsibility and Sustainable Development as well as their benefits and challenges.*

**Keywords:** *Corporate Social Responsibility, Sustainable Development, Societal Needs, Strategic Decisions*

## INTRODUCTION

Corporate Social Responsibility (CSR) is undergoing metamorphosis in business and public platform and has become a strategically important issue crossing all organizational boundaries, and affecting the business of the company. Various organizations have changed their core values to include in them social responsibility. An organization has various responsibilities towards all its stakeholders and fulfilling these responsibilities assures sustainable growth of an organization.

CSR is described as an approach by which a company understands that its activities influence the society and in turn the developments in the society have impact on its business sustainability. It is a process by which the company manages the economic, social,

---

<sup>1</sup> Research Scholar Maharaj Vinayak Global University, Jaipur  
E-mail: Sanjanatewari.ihs@gmail.com

environmental and human rights impact of its activities both locally and across the world, basing these on principles which reflect both international values and the organizations own values (ethics), reaping benefits for both its own operations and reputation as well as the communities in which it operates.

Corporate social responsibility is the buzzing words in every sphere of the corporate sector. Corporate social responsibility has its ethos in the business self regulation, which is considered as integrated and inseparable part of the business models. In today's competitive scenario the importance of corporate following social responsibility towards all its stakeholders is essential for its sustainability. The stakeholders play a very crucial role in the success of a business as they have a primary stake in the business. Most of the top listed companies are becoming more responsible ensuring that economic growth is accompanied by social progress. The CSR approach envisages evolving and executing strategies to support communities. Corporate sector is very much an integral part of the society therefore it becomes an ethical responsibility of the corporate sector to carry on the responsibility of their society and here arises the real meaning of CSR. Hence, CSR apart from social responsibility has also added a universal concern to the business world where the safety and security of environment and human rights is at the prior. Be it the charity given by the businessmen in the pre-industrialization phase or the ancient Indian perspective as mentioned in our Rig Veda (1-8) where certain obligations are being expected from the king to his subjects; in a way they all related to CSR. CSR plays the connecting role between the media, society and investors; while media and society act as the touchstone in checking the credibility of the CSR activities of the company; investors encourage the company to keep enhancing their social responsibility by investing in the particular company through the feedback and result being shown by the media and society. Thus, CSR promotes the growth of a healthy business, in a safe environment, for a healthy generation, to establish a safe society.

## **LITERATURE REVIEW**

Over the past decades CSR has become a very important topic of research for the researchers.

Windsor in 2001 mentioned in his article the future of CSR and interrelationship between business and society. He tried to focus on the future trend of the concept and the transformation it will go through.

In 2008 Vaaland, Heide published paper based on a case study methodology. The purpose of the paper was to study the critical incidents in CSR and utilize the results in enforcing the CSR activities.

An article published in *The Economic Times* named as "CSR: A cloak for crooks" on 21 Oct. 2012 explored that there are so many companies which have engaged in Corporate Social Responsibility but still they are suffering from financial crisis, fraud and other unsocial causes.

Shreya Ghosh in her paper "Importance of Corporate Social Responsibility" published in [www.indianyouth.net/importance-corporate-social-responsibility-csr/](http://www.indianyouth.net/importance-corporate-social-responsibility-csr/) beautifully states "Corporate Social Responsibility is a self-regulatory form of corporate conscience included

into business models whereby it is guaranteed that the business is keenly accommodating with the force of law and ethical standards according to national and international norms. The term has been in use since the 1960s and maintained its usage extensively to shield legal and moral responsibility. Ever since its inception this sustainability strategy has been opted by companies to reflect their competitiveness. Their overall aim is to impact the society positively while get the most out of the creation of shared value for the shareholders, stakeholders and even employees.”

### OBJECTIVE OF THE STUDY

- To explore a different perspective of CSR.
- To redefine the relation of concept of the word business and society.
- To highlight the effective and successful CSR initiatives and its interrelationship with Sustainable Development.
- To discuss the various benefits and challenges of CSR.

### RESEARCH METHODOLOGY

The paper is secondary data based. Secondary data has been collected from various reliable sources like Journals, internet, books, research papers and government websites.

### CSR AND SUSTAINABLE DEVELOPMENT

Sustainable development is defined as the development that meets the current needs without compromising the ability of future generations to meet their needs. In the current scenario Sustainable Development has occupied national as well as international agenda because it focuses on realizing the core values in cultural, technological, environmental and economic domains. These are the four main pillars of achieving Sustainable Development.

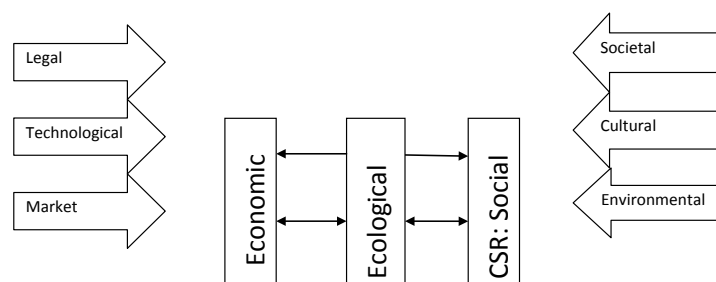

Sustainable Development via Corporate Social Responsibility is important to create a balanced, harmonious and welfare oriented approach for growth and progress. The entire society is interrelated and interdependent and business houses need people, raw material and a cooperative environment available in the society, to be successful. And as per recent surveys consumers prefer to buy products of companies that are sensitive towards CSR .

The business houses today have to be socially, ethically and economically responsible. A lot of companies have contributed towards social welfare and Sustainability Development

via Corporate Social Responsibility by taking initiatives to reduce greenhouse gases emission, contributing to health and hygiene, education, rural development, employment generation etc. Big firms in India like Reliance and Tata are very actively involved in taking measures for CSR and contribute fully to the society. Infact IBM has even collaborated with Tribal Development Department of Gujarat to develop the tribal of Sasan area of Gir Froests.

CSR, in compliance with rules, regulations and legislations is committed to activities pertaining to:

- Health and safety;
- Environmental stewardship;
- Human rights (including core labour rights);
- Sustainable development;
- Conditions of work (including safety and health, hours of work, wages);
- Industrial relations;
- Community involvement, development and investment;
- Involvement of and respect for diverse cultures and disadvantaged peoples;
- Corporate philanthropy and employee volunteering;
- Customer satisfaction and adherence to principles of fair competition;
- Anti-bribery and anti-corruption measures;
- Accountability, transparency and performance reporting; and
- Supplier relations, for both domestic and international supply chains.

### **BENEFITS OF CSR**

As we have now understood the meaning of CSR and its means and what it stands for, we will go through the advantages of CSR.

#### **Improvement in the Image of the Corporation**

One of the factors by implementing CSR policies is it would enhance the goodwill value. It would be helpful in two ways – the people would buy the product because of clean image the corporation has made by making awareness of their products and other corporations would be interested in getting associated. This would increase the reliability and make a name of the corporation to a high level in its field. More and more people would like to get associated with the corporation of such stature.

#### **Increased Attraction and Retention of Employees**

Companies with strong CSR policies would be able to hire new recruits and retain their employees. Companies taking the initiative for providing good working conditions and taking care of the employees, people would draw towards these companies with full desire and interest. no difference between the new employees and the working ones raises bars in the efficiency of the companies. Taking care of employees in personal factors as in anniversaries, birthdays, financial help in needy times will make the employee stay in the company.

It would be an advantage during the requirement of labor situation. Increasing the incentives during these situations would lower the cost of training new recruits as well as I would make the existing employees give good results and the company would earn profit due to their efficiency.

### **Regulatory Authorities Become Less Hostile**

Corporation with CSR polices have an advantage with regulatory authorities as they would not be held by the authorities more over they would be supported and would be lenient in the paper work of any project or set up due to the image of the company as it is following the CSR program. Were as companies who do not follow CSR programs are always under the scanner and face problems with the authorities.

### **Attracts More Capital Inflow from Various Sources**

Once the image of the company has been set up in the market , investors from everywhere and from different fields would be interested getting associated and invest in company , this would increase the brand value as well as the profits of their company as it has improvised using CSR programs . Foreign investors would be interested and it would bring in foreign exchange helping the country and making a mark of a trust worthy corporation.

#### **Generation of Clean and Renewable Energy from Environmental CSR**

Company investing in an environmental CSR program would make sure that it does not harm the environment anyhow. Bring in new techniques machinery and other means to lower the effects and improve the cleanliness of the environment. This would also improve the production cost and opportunity to find different ways of finding usage of recycled energies and products.

### **Positive Publicity**

In today's date there many ways of publicity but word of mouth matters as it spreads faster than any other advertisement. It also tells about company and its products. company having a good CSR program increases the brand value amongst t its competitors as the employees give good results and the products of such company even if at a bit higher cost is bought .

## **CHALLENGES TO CSR**

### **Laws and Legislations**

Many companies have already adopted CSR policy. Previously, governments depended on the rules and laws to promote and implement social and environmental deveopments. Shrinking government resources, has led to the exploration of voluntary and non-regulatory initiatives instead.

- (i) Limitations of jurisdictions
- (ii) No direct responsibility imposed on the purchasing firms.
- (iii) Difficulties in auditing

### **Ethical Consumerism**

Ethical consumerism is the intentional purchase of products and services that the customer considers to be made ethically. This may mean with minimal harm to or exploitation of humans, animals and/or the natural environment. Consumers today are very aware and want to buy products of companies that are morally and ethically responsible. Ethical consumerism is practiced through ‘positive buying’ in which ethical products are favoured, or ‘moral boycott’, that is negative purchasing and company-based purchasing.

### **Social Awareness**

The general public has little or no knowledge of CSR initiatives of the companies. The situation is further aggravated by a lack of communication between the companies involved in CSR and the general public at the grassroots.

### **Corporate Green Washing**

Greenwashing is when companies attempt to advertise and promote their product to be “green” and claim to be minimizing environmental hazards and pollution but in reality do not implement the required policies and procedures

### **CONCLUSION**

We are living in a world where the whole world is our home and hence only the holistic development of the whole world can lead the human race to a realistic dream world. Right from the ancient civilization to the twenty first century it is the business that has always been the strongest base of the human society. Business plays a very crucial role in the world therefore it becomes the ethical responsibility of every businessman and entrepreneur to pursue a business which is carried on for the welfare of human race and human society. Business houses today are understanding that CSR initiatives are the need of the hour and are contributing fully towards the societal development. How sustainably a company is contributing in the society has become a vital touchstone to judge the credibility of a company. Therefore, the success of the companies in the present era depends very much on the degree of effective CSR activity done by it.

### **REFERENCES**

- [1] <http://inbusinessmag.com/building-your-business/top-10-best-strategies-business-success#.WGDbLtJ97Mw>
- [2] <https://www.nestle.in/aboutus/nanhi-kali>
- [3] Ministry of Law and Justice (2013), The Companies Act, 2013 (NO. 18 OF 2013), August 29, 2013, New Delhi.
- [4] Herrman, K. K. (2004), “Corporate Social Responsibility and Sustainable Development: the European Union Initiative as a Case Study”, *Indiana Journal of Global Legal Studies*, Vol. II, Issue, 2, Article 6
- [5] Sharma, A. and Kiran, R. (2013), “Corporate Social Responsibility: Driving Forces and Challenges”, *International Journal of Business Research and Development*, Vol. 2 No.1, pp. 18-27.

# Digital India – The Implimentation

MANISH SINGH<sup>1</sup>

## Abstract

*We are living in the digital era, where technology has become the vital ingradient of our survival. We can not recluse ourselves from this Digital World. Keeping in mind this mushrooming technological world Government of India launchehd the ‘Digital India’ Program on 1st July 2015. This program focused on providing the government services electronically by developing better digital infrastructure, enhancing internet connectivity and making country digitally powerful in every field . It can better d said that basic motive for the launch of this program is to connect rural area with high speed internet network and providing digital literacy.*

*The Digital India is facing many serious obstacles for its implementation, this research tries to provide solution to such implementation issues.*

## INTRODUCTION

We are living in the digital era, where technology has become the vital ingradient of our survival. We can not recluse ourselves from this Digital World. Keeping in mind this mushrooming technological world Government of India launchehd the ‘Digital India’ Program on 1st July 2015. This program focused on providing the government services electronically by developing better digital infrastructure, enhancing internet connectivity and making country digitally powerful in every field . It can better d said that basic motive for the launch of this program is to connect rural area with high speed internet network and providing digital literacy.

Core component of Digital India Program are

- The creation of digital infrastructure
- Delivering services digitally
- Digital literacy

Digital India is a broad base term used for the government efforts to make government services accessible to mass anywhere, anytime and on user friendly and secured device. Government will be ready for this big move by connecting every possible government service with E-power. With successful accomplishment of this program India can achieve the objectives of:

- Information for all
- Leadership structure
- Education for all
- Broadband for all

---

<sup>1</sup> Assistant Professor, Indirapuram Institute of Higher Studies, Ghaziabad  
E-mail: Manishsingh.iihs@gmail.com



With this program Government aims to make government services available to people digitally easily and enjoyment of the fruits of the latest information and technological innovations. It is a program to prepare India for a knowledge future.

### **OBJECTIVES OF THE STUDY**

The Digital India Program me faces many obstacles and hurdle In its implementation. This research tries to provide solution to all such barriers and provide some remedies for its successful implementation and help in making a better future for every one. This research also focuses on

- To understand the concept of Digital India.
- To know the impacts of Digital India on society.
- To find out the challenges faced in the implementation of this project.

### **RESEARCH METHODOLOGY**

Secondary data is used to carry out this research. The secondary data used is collected through extensive trolling of research paper, articles, professional information, report apart from books, magazines. It is exploratory in nature as it provide a clear guidance for empirical research. It is also descriptive where focus is on fact finding and investigation with proper interpretation.

### **LITERATURE REVIEW**

A number of research papers and articles provide a detailed insight about the role of digital India and the implications of this project in India. The peculiar findings from the literature are as

Jain (2015) suggested that some transformable changes are required in the various programs launched under Digital India to achieve desired objectives.

Sharma (2015) described that in the Digital India project age every civilian has a bright prospect to transform the lives in many ways that were hard to envision just a couple of year's ago. It was concluded that more prospects will open for the youth that will boost the nation's economy.

### **VISION OF THE DIGITAL INDIA**

The vision is centered on three key areas:

- I. Digital infrastructure as a utility to every citizen:** It aims at to provides high speed internet as a core utility public services like certificates, the land records, and many more which will be made available online or on the public cloud. It targets to provided a safe and secure cyber space in the country.
- II. Governance and services on demand:** – to provide every government services or information is available in real time from online & mobile platforms. It makes financial transactions electronics & cashless. This will create a single window access to every individual.

**III. Digital empowerment of citizens:** - All digital resources will be available universally in Indian languages. All documents and certificates to be available on the cloud.

### **Pillars of digital India**

These three vision areas further targets ‘Nine Pillars of Digital India’. Which are as

1. *Broadband highways*

The government with the vision of digital India has allocated 5 billion to build high speed broadband highways connecting all the villages, government department, university etc. This is a key driver in addressing the challenges in the development goals through fibre networks. The participation of private players is very important for faster rollout of optic fibre networks across the length and breadth of a country like India.

2. *E-governance*

The national e-governance plan has been formulated by the department of electronic and information technology, and department of administrative reforms and public grievances. This project works in both centralized and decentralized way. There are many different initiatives from central Government as well as state government under this project to ensure government services are available to citizen’s electronics.

3. *E-kranti*

This project provides electronic delivery of services to the citizens. The government has allocated 5 billion for the e-kranti project which includes e-health, eeducation, and technology for farmers, technology for planning, technology for security, technology for financial inclusion, and technology for justice.

4. *Universal Mobile Access*

In the coming years, network technologies like 3G,4G and 5G will storm the speed. Government is specially preparing to connect unconnected areas and speedy use of these technologies. General public will access the online government services with the help of handheld devices. Nation is ready to be well-connected, efficient and more productive in every aspect.

5. *Public Internet access*

Virtuous technologies that support cost containment, collaboration, security, services on the go, social connect, and in-built intelligence that deliver remote access to any information or service available across the domain. This change will open new doors of e-services to every citizen.

6. *Information for all*

Websites and mobile apps will convey data and realistic participation and through social media. Everything is connected through virtual networks. Swift work flow and no delays due to wait in queues.

7. *Electronics manufacturing*

This milestone will create a huge base for electronics manufacturing in media with the aid of digital technologies and skills. The empowerment of manufacturing

through the internet of things will enable intelligent workshops that demonstrate data driven operational excellence and decentralised production control systems within and beyond the physical factory walls.

#### 8. *IT for jobs*

The government is preparing to provide training and teaching skills to the youth for employment opportunities in the IT sector. BPO industries will be established for the fastest growing segment of the IT enabled services industry. It offers e-services 24/7 in every field and gives more jobs potentials.

#### 9. *Early Harvest Programme*

This programme will gain of its rate short timeline projects where every manual service is altered by e-service. E-services like educational books to e-books, public Wi-Fi sports to access online game.

### **SCOPES OF DIGITAL INDIA**

- The scopes for the implementation of this programmes can be understood as
- The Digital India will be a great plan for developing India for a Knowledge future
- It will weaves together a large number of innovations and thoughts in to one single golden ball which will be more comprehensive and valuable
- This scheme will launch more related programs like E-Health, E-Sign, E-Education etc
- Each related individual variable will stand of its own
- The Branding of program as Digital India highlights there transformative impact as whole

### **IMPACTS OF DIGITAL INDIA**

The digital India project provides a huge opportunity to use the latest technology to redefine India the paradigms of service industry. A digitally connected India can help in improving social and economic condition of people living in rural areas through development of non-agricultural economic activities apart from providing access to education, health and financial services. There are some impacts of digital India which are as follows:-  
**Economic Impact:-**It can play a key role in macro economic factors such as GDP growth, employment generation, labour productivity, growth in number of businesses and revenue leakages for the government. **Social Impact:-**Social sectors such as education, healthcare, and banking are unable to reach out to the citizens due to obstructions and limitations such as middleman, illiteracy, poverty, lack of funds and investments. Modern ICT makes it easier for people to obtain access to services and render it to masses. The penetration of mobile devices may be highly useful as a complementary channel to public service delivery apart from creation of entirely new services. **Environment Impact:-**The major changes in the technology space have not only brought changes to the economic system but are contributing to the environment changes. The next generation technologies are helping in lowering the carbon footprint by reducing fuel consumption, waste management, greener management, greener workplaces and thus leading to a greener ecosystem.

### **OBSTACLE IN THE PATH OF DIGITAL**

Digital India is a great plan but its improper implementation due to inaccessibility & inflexibility to requisite can lead to its failure. A few barriers of the Digital India programme are as follows –

1. Each pillar has its own limitations.
2. Infrastructure deficit such as lack of digital knowledge, especially in the country side.
3. Implementing digital knowledge in the actual field.
4. Beneficiaries sometimes don't have adequate knowledge of DIP.
5. Additional services such as health, education, banking, governance etc may not be well developed.
6. No separate department for consumer to readdress under the program.

### **REMEDIES**

1. A few new programs are needed particularly in electronics manufacturing domain and skill development.
2. Need for dedicated training institute in each state under DIP, to create the digital literacy and awareness level at every step
3. Involving youth for making effective DIP.
4. Seminars can be conducted to aware people about the digital services.
5. To advertise the different varients of DIP on Books, pen, TV, newspapers etc. so that people could aware about the e-services.
6. Hosting a lecture about Digital India in every educational institute to enhance the policies of DIP.
7. Help-line number can be launched of DIP so that people can tell the problems relating to e-services.
8. Help center can be provided in each state to solve public issues.
9. The booklets of e-Services should be printed with picture and can be distributed for awareness.
10. Turn the villages into smart economic centers that connects farmers directly to e-Markets to know the well price of crops.

### **CONCLUSION**

The vision of the scheme is to transform India into a “Digitally Empowered” society and knowledge economy. Some of the crucial projects are under various stages of implementation which may require some transformational process reengineering, renovation and adjustment of scoping and implementation strategy to achieve the desired service level objectives. All educational institutions and government services will soon be able to provide E-ways round the clock. Tech masters from all over the world are willing to actively participate in this dream campaign. More employment prospects will be open for

the youth that will boost the nation's economy. Let us all look forward for the successful implementation for this project for the brighter and prosperous India and hope India will again called a Golden Sparrow.

## **REFERENCES**

- [1] [https://en.wikipedia.org/wiki/Digital\\_India](https://en.wikipedia.org/wiki/Digital_India)
- [2] [http://www.worldwidejournals.com/indian-journal-of-applied-research-\(IJAR\)/file.php?val=October\\_2015\\_1444211851\\_\\_223.pdf](http://www.worldwidejournals.com/indian-journal-of-applied-research-(IJAR)/file.php?val=October_2015_1444211851__223.pdf)
- [3] [http://www.csiindia.org/communications/CSIC\\_April\\_2015.pdf](http://www.csiindia.org/communications/CSIC_April_2015.pdf)
- [4] <http://digitalindiainsight.com/what-is-digital-india-campaign>
- [5] <http://www.mapsofindia.com/my-india/government/modis-digital-india-plan-faces-real-worldchallenges>
- [6] [http://www.ijaresse.com/docs/papers/Volume\\_5/8\\_August2015/V5I8-0192.pdf](http://www.ijaresse.com/docs/papers/Volume_5/8_August2015/V5I8-0192.pdf)
- [7] <http://pib.nic.in/newsite/PrintRelease.aspx?relid=108926>
- [8] <http://digitalindia.gov.in/content/approach-and-methodology>

# A Study on Consumer Adoption towards Digital Modes of Payments with Special Reference to Gwalior City

PANKAJ MISHRA<sup>1</sup> AND ANIL VASHISHT<sup>2</sup>

## Abstract

*Digital mode of payment refers to the way of payment which is made through electronic digital devices. In digital payments, payer and payee both use digital medium to send and receive money. It is also called electronic payment. No hard cash is involved in the digital payments. All the transactions in digital payments are completed online. The recent move by Shri Narendra Modi led government of demonetizing high value currency notes to wipe out black money has added fuel to the practice by pushing more number of people to use digital modes of payments.*

*Different types of digital payment methods being made available to consumers are – Banking Cards, USSD, Aadhar Enabled Payment System, Mobile Wallets, Bank Prepaid Cards, Point Of Sale Machine, Internet Banking, UPI, Mobile Banking and Micro ATM*

*The adoption of digital payment instruments by end consumers is expected to provide a mass movement of payment systems towards electronic mediums and the economy is likely to further support this change. Different e-commerce companies and online payment players as well as app-based taxi services are the major initiators of use of digital/electronic modes of payments by consumers in India.*

*Various researchers have attempted to study the awareness and usage behavior of consumers towards digital modes of payments specifically internet banking and mobile banking.*

*Contini et al., (2011) believe that there has been a shift from “enabling a mobile device to be used as a browser; accessing existing internet-based banking and retail systems.... to the use of an application-enabled mobile phone as a payment form, substituting for a check, cash or a card, to eventually create a mobile wallet”. Mallat (2007) studied people’s willingness to use mobile payments and revealed that such payment technology can be beneficial when dealing with small value transactions such as movie tickets or bus tickets, and the barriers to the adoption of mobile payment included the complexity of mobile payment services (e.g., the use of SMS with various payment codes and premium service numbers that are difficult to remember) and perceived risks and trust in mobile payment service.*

*The current research work aims to explore the consumer adoption towards different digital modes of payments available with special reference to Gwalior City.*

**Keywords:** Digital Payment, Mobile Payment, Consumer Adoption

<sup>1</sup> Research Scholar, Amity Business School, Amity University Madhya Pradesh, Maharajpura, Gwalior, (MP)  
E-mail: pmishra2@gwa.amity.edu

<sup>2</sup> Director, Amity Business School, Amity University Madhya Pradesh, Maharajpura, Gwalior, (MP)  
E-mail: avashisht@gwa.amity.edu

## INTRODUCTION

Post November 8<sup>th</sup> 2016, in India, the only thing which was troubling every consumer's mind was the dilemma of choosing a safe, secure, convenient and cashless payment option. With the vision of Govt. of India to transform the country into a digitally empowered society and knowledge economy, different modes of digital payments were made available to the citizens. Most prominent ones are: *Banking Cards, USSD, Aadhar Enabled Payment System (AEPS), Mobile Wallets, Bank Prepaid Cards, Point Of Sale Machine, Internet Banking, UPI, Mobile Banking and Micro ATM*

*Banking Cards* offer consumers more security, convenience, and control than any other payment method. The wide variety of cards available – including credit, debit and prepaid – offers enormous flexibility, as well. These cards provide 2 factor authentications for secure payments e.g secure PIN and OTP. RuPay, Visa, MasterCard are some of the example of card payment systems. Payment cards give people the power to purchase items in stores, on the Internet, through mail-order catalogues and over the telephone. They save both customers and merchants' time and money, and thus enable them for ease of transaction.

*The Unstructured Supplementary Service Data (USSD)* service is being provided in the form of \*99#. This service allows mobile banking transactions using basic feature mobile phone, there is no need to have mobile internet data facility for using USSD based mobile banking. Key services offered under \*99# service include, interbank account to account fund transfer, balance enquiry, mini statement besides host of other services. \*99# service is currently offered by 51 leading banks & all GSM service providers and can be accessed in 12 different languages including Hindi & English.

*Aadhar Enabled Payment System (AEPS)* is a bank led model which allows online interoperable financial transaction at PoS (Point of Sale / Micro ATM) through the Business Correspondent (BC)/Bank Mitra of any bank using the Aadhaar authentication.

A *Mobile wallet* is a way to carry cash in digital format. You can link your credit card or debit card information in mobile device to mobile wallet application or you can transfer money online to mobile wallet. Instead of using your physical plastic card to make purchases, you can pay with your smartphone, tablet, or smart watch. An individual's account is required to be linked to the *digital wallet* to load money in it. Most banks have their e-wallets and some private companies. e.g. *Paytm, Freecharge, Mobikwik, Oxigen, mRuppee, Airtel Money, Jio Money, SBI Buddy, itz Cash, Citrus Pay, Vodafone M-Pesa, Axis Bank Lime, ICICI Pockets, SpeedPay* etc.

*Bank Prepaid Cards* allow consumers to load money into it using a bank branch or internet banking. On loading the pre-paid card, customer may pay service charges for transaction or fixed fee, upfront + each transaction. Services offered on bank prepaid cards are: Balance Enquiry, Passbook/Transaction history, Add money Touch and Pay, Manage Profile, and Notifications, etc.

A *point of sale (PoS)* is the place where sales are made. On a macro level, a PoS may be a mall, a market or a city. On a micro level, retailers consider a PoS to be the area where a customer completes a transaction, such as a checkout counter. It is also known as a point

of purchase. For service initiation, Handheld Device with card and /or bio-metric reader, Merchant Bank a/c and Internet connectivity GPRS/ Landline are needed.

*Internet banking* also known as online banking, e-banking or virtual banking, is an electronic payment system that enables customers of a bank or other financial institution to conduct a range of financial transactions through the financial institution's website. Different types of online financial transaction methods available are: *National Electronic Fund Transfer (NEFT)*, *Real Time Gross Settlement (RTGS)*, *Electronic Clearing System (ECS)* and *Immediate Payment Service (IMPS)*.

*Unified Payments Interface (UPI)* is a system that powers multiple bank accounts into a single mobile application (of any participating bank), merging several banking features, seamless fund routing & merchant payments into one hood. It also caters to the "Peer to Peer" collect request which can be scheduled and paid as per requirement and convenience. Each Bank provides its own UPI App for Android, Windows and iOS mobile platform(s).

*Mobile banking* is a service provided by a bank or other financial institution that allows its customers to conduct different types of financial transactions remotely using a mobile device such as a mobile phone or tablet. It uses software, usually called an app, provided by the banks or financial institution for the purpose. Each Bank provides its own mobile banking App for Android, Windows and iOS mobile platform(s).

*Micro ATM* is a device that is used by Business Correspondents (BC) to deliver basic banking services. The platform will enable Business Correspondents (who could be a local kirana shop owner and will act as 'micro ATM') to conduct instant transactions. The basic transaction types, to be supported by micro ATM, are Deposit, Withdrawal, Fund transfer and Balance enquiry.

## **LITERATURE REVIEW**

Different factors have come into play which affect the adoption of digital modes as a payment medium such as trust, expressiveness and perceived ease of use, playing a crucial role in facilitating adoption of digital payment solutions (Padashetty & SV, 2013).

Safety and security of payment as compared to traditional methods acts as one of the other driving force (Rai, et al., 2012). Security and privacy were the major concerns for the consumers which affect the adoption of digital payment solutions (Dahlberg & Mallat, 2002). Factors like authentication, confidentiality, integrity of data were identified to have a positive effect on users trust in digital payment methods. Digital wallet payments bring extra convenience to shoppers by offering flexible payment additions and accelerating exchanges (Liu & Zhuo, 2012). Demographics also play an important role in adoption of any new technology. In India consumers younger than 35 years of age are nearly double to download a mobile app in their mobile phone in comparison to over 50 years of age. More than half of those consumers, use digital wallets at least once in a week, most commonly for exploiting special offers such as coupons, discounts etc. (Digital Research Inc., 2013).

Rajesh Krishna Balan, Narayan Ramasubbu and Giri Kumar Tayi studied in their paper "Digital Wallet: Requirements and Challenges" (2006) the requirements and challenges of adoption of digital wallets in Singapore. Further they discussed why Singapore is ready



for a digital wallet and identified the key challenges in building and deploying a digital wallet. Pousttchi (2003) found that confidentiality of data was most important criterion for adoption of mobile payment solutions thus relating to the results of previous studies of perceived privacy and security. Some people also see this in terms of ease of use which is the degree to which a person finds using a technology free of effort. It is demonstrated that convenience and handiness of a technology play s an important role in adoption of electronic commerce and further use of digital wallets (Anckar. et al., 2003).

### **RESEARCH METHODOLOGY**

The research study was conducted among 75 residents from different localities of the city. The Descriptive as well as Exploratory research design was adopted for the study. A structured questionnaire containing closed and open ended questions was administered to the respondents, who were selected using Judgment sampling method for obtaining responses.

### **FINDINGS AND CONCLUSIONS**

The study was conducted to find out the level of adoption of digital payment methods and user habits of residents in Gwalior city. The findings of the study are mentioned as below:

1. The primary reason for people switching to digital modes of payment was sheer convenience. The study showed that 84% people opted digital modes because of convenience involved, whereas only 16% respondents claimed that shortage of currency was behind their use of digital payment methods.
2. People do have various concerns towards usage of digital payment methods. The 66% respondents were worried about identity theft and security concerns, whereas 19% were troubled about poor internet connectivity. Also, 15% people emphasized on lack of technical know how regarding use of digital payment methods.
3. Out of different modes of digital payments available, the Netbanking was being used by most number of respondents (76%). However people were using different methods simultaneously. Therefore it showed that 52% were using Bank debit and credit cards. However the mobile apps and e-wallets were being used by only 12% of respondents.
4. When asked whether they will continue to use cashless payments if currency notes come back into circulation, around 45% respondents said that they will continue using digital payment methods for most of their transactions. Whereas 34% people intended to use digital methods for some of their transactions and 15% people claimed to use digital methods for rare transactions. Only 6% people said that they will prefer not to use digital payment methods once they witness currency notes back in circulation.
5. The safety behaviour of respondents was explored, when asked that how often they change device passwords and PIN of their debit/credit cards. Around 34% people said they change it once in 6 months, 28% people change it once in a year, 8% people change it every month and 30% people never changed their passwords.

6. Further, it was came to light that some of the people prefer convenience over safety, as around 35% people don't mind accessing unsecure Wi-Fi. Also, around 32% people store financial details on their devices, like laptops and mobile phones.

The above findings revealed that while people are getting comfortable with cashless payments, some mindset issues are holding back many from embracing the newer platforms. The findings also suggest that the usage habits of those who have taken to digital modes of payments could be exposing them to security threats.

## **RECOMMENDATIONS**

The study revealed that majority of people, who opted for digital payment methods for conducting their financial transactions, were driven by their convenience. However the situational cash crunch can also not be undermined to be taken as a factor behind increased usage of digital payment methods. It was seen that people those were initially reluctant towards using new digital technology based services, also started moving towards digital payments.

However in the current situation, it would be highly recommended that in order to maintain and increase the current pace of adoption of digital payment methods, the incentive based schemes, like discounts and cash back either from the government side or by the private players should be provided and continued to the people. At the same time the efforts should be increased to provide common people with the basic know how of how to operate the digital devices, as well as make them aware about threat and security issues involved in usage of digital modes of payment. A country wide campaign should be launched to make people aware and skilled towards usage of digital devices. They should also be made to learn about the dos and don'ts of digital service platforms.

## **REFERENCES**

- [1] Padashetty, D. S. & SV, K. K., (2013), An Emperical Study on Consumer Adoption of Mobie Payments In Bangalore City—a case study. *ResearcherWorld, Journal of Arts, Science &Commerce*, IV(1), pp. 83-94.
- [2] Rai, N. et al.,(2012), M-wallet: An SMS based payment system. *International Journal of Engineering Research an d Applications*, Issue ISSN: 2248-9622, pp. 258-263.
- [3] Dahlberg, T. & Mallat,N., (2002), *Mobile payment service development - Managerial implications of consumer value perceptions.s.l.*, ECIS.
- [4] Liu, S. & Zhuo, Y., (2012), *Theconsumer implications of the use of electronic and mobile payments systems.* pp.1-49.
- [5] Digital Research Inc., (2013), *Mobile application and Digital Wallet usage, USA:Cashstar*
- [6] Pousttchi, K., (2003), *Conditions for acceptance and usage of mobile payment procedures.* Vienna, MPRA.
- [7] Ankar, B., Walden, P.& Carlsson, C., (2003), *Factors Affecting Consumer Adoption Decisions and Intents in Mobile Commerce: Empirical Insights.* Slovenia, BLED 2003 Proceedings
- [8] [http://cashlessindia.gov.in/digital\\_payment\\_methods.html](http://cashlessindia.gov.in/digital_payment_methods.html)

# Analytical Study on What Consumers Demand, Expectations and Perceptions Are

AITEEQ AHMED<sup>1</sup>

## Abstract

*The Aim of this work is to examine selected elements, which have control on customer satisfaction in services. The investigation is conducted both from a theoretical and empirical point of view. The theoretical analysis considers four aspects. The first aspect is concerned with the service company's internal services, which have an indirect influence on the overall customer satisfaction. It focuses on internal services which involves an analysis of operations, processes, and activities which influence the behavior of employees within service companies, e.g. internal marketing decision making processes, management styles, communication patterns, empowerment, and employee motivation.*

*The second aspect deals with the external value and therewith the relation between service providers and their customers. It focuses on issues of strategic service marketing relating to customer satisfaction, e.g. service marketing mix, service delivery, and service come across. The third aspect takes the concept of service quality into account which corresponds to the level of customer satisfaction. Service quality is determined by the following criteria.*

**Keywords:** *Customer Satisfaction, Management Styles, Empowerment, Employee Motivation, Service Quality*

## INTRODUCTION

As with many other western societies, few countries has moved an economy based on agriculture to an acronym based mostly on services. South Asia is becoming a mostly service-based economy. The tertiary sector includes private businesses for example banking, insurance companies, hotels, restaurants, consulting, repair and maintenance, supermarkets, travel agencies, transportation, and others. In addition to the private businesses, we also find public services like hospitals and social institutions, education, tax offices, etc.

In today's increasingly competitive environment, quality services and customer satisfaction are critical to corporate success. Delivering high quality services is closely linked to profits, cost savings and market share. As stated by Piercy (1995), it is striking that one of the few elements that links many of the otherwise disparate recommendations made to managers over the past several decades has been the need to focus on customer

---

<sup>1</sup> Associate Professor, IIMT College of Management, Greater Noida (UP)

satisfaction as a route to constant high performance authors (Ballantayne *et al.* 1996; Berry, 1986; Collier, 1994; Schneider and Bowen, 1995): It is easier - and much cheaper - to keep existing customers than to get new ones. Additionally, another benefit from achieving satisfied customers is the fact that the willingness to repurchase is much higher for satisfied customers than for dissatisfied and indifferent ones. In spite of this awareness concerning the importance of customer satisfaction, it is beyond the ability of many of today's service companies to maintain satisfied customers.

### **Problem Formulation**

From a firm's perspective it is important to ensure that customers are satisfied with the product they purchase as well as with the way the product is delivered. This is true for companies producing pure goods or pure services, or for companies selling goods and services. Customers have specific needs, expectations, and perceptions, but if a company is not able to exceed or at least meet these expectations, the customer becomes dissatisfied and probably does not consider a repurchase.

According to Parasuraman *et al.* (1995), the larger the gap between a company's and customer's perception concerning both service product and service delivery the smaller the probability of satisfying the customers. This indicates that service providing companies and to have a more profound understanding of their the crucial question. An investigation of the relationship between service provision and customer satisfaction appears therefore of interest.

### **Identifying the Problem**

In spite of the growing awareness among South Asian service companies only have succeeded in reaching adequate levels of customer satisfaction. In order to explain the sources of service failure, it is of interest to examine the theoretical relationships between service companies and the satisfaction of their customers. A thorough investigation of all elements constituting to this relationship is beyond the scope of this thesis, hence we have chosen to narrow down the analysis to encompass only a specific number of elements affecting customer satisfaction.

### **Overall Methodology**

Based on our research we have identified various ways to describe the relations between service company's performance, and customer satisfaction. However, most models and theories cover only some aspects of the elements which we have identified as being important: Effective internal operations, external value, customer satisfaction, and the profitable consequences of achieving customer satisfaction. Only one particular model - The Service-Profit Chain - was found to encompass all the elements of interest; thereby ensuring a holistic view of customer satisfaction in a service context. The Service-Profit Chain - originally developed by Hooksett *et al.* (1998) - is based on the convergence work being carried out by Reinhold and Sesser (1996) concerning customer satisfaction and loyalty.

Customer satisfaction or dissatisfaction as outcome of the provided external value, is the link of the chain. This includes both the identification of key parameters influencing and enhancing customer satisfaction in relation to services, and the examination of service quality models which play an important role in this context. Customer dissatisfaction might lead to defection in the long-run; customer satisfaction, to retention and loyalty.

### **Employee Involvement**

In order to ensure a high employee commitment, researchers suggest to increase the level of employee involvement. Waterman (1998) identifies three central elements concerning employee participation: Influence, interaction, and information sharing. Their model has been improved by Marchington (1996). He classifies employee involvement into three elements: First, employee participation in the decision making process without the intention to quantify their impact on the final decision. Second, employees intention to have an impact on the decision making process and the final decision. Finally, employees' ability to link participation and control in decision making processes.

### **Managerial Issues in Decision Making**

Managers are supposed to make decisions. This is certainly true for companies producing goods and for companies providing services. In general, one can distinguish between two main streams of theories concerning decision making (Schermerhorn *et al.*, 1991). The first one of interest is the classical decision theory. This theory assumes that everything is certain implying that the manager knows all alternatives and consequences his decision has. This theory has been criticized for being hypothetical, static, and unrealistic.

The second theory is the behavioral decision making style. This theory explains decision making processes in an uncertain world. Managers make decisions with respect to their individual perception of situations and have only limited information available. They choose the alternative which satisfies them best (Simon, 1977).

The three basic decision making methods have been further expanded by Vroom and Jago (1998). They suggest two variants on the authority decision. The first one is that the manager makes the decision solely based on the information available to him at that time. The other variant implies that the manager obtains information from employees and then decides on the problem solution. Employees are not directly involved in the gathering of alternatives.

Concerning the consultative decision making style Vroom and Jago (1998) propose two further distinctions. The first variant is that the manager gets information and alternative ideas for solving the problem from different employees, thereafter, making the final decision himself. The key factor is that those employees are not brought together, indicating that no discussion or joined alternative gathering takes place among the manager and subordinates. The second variant of the consultative decision is that the manager initiates a discussion between employees concerning a problem. Suggestions and ideas are obtained collectively, but the manager makes the final decision by reflecting on the discussion.

Due to a distance from the real problems which occur during production or with customer relations, it can be a disadvantage for the organization, when the manager decides individually. This can provoke misunderstanding between the manager and employees and can thereby create employee resistance because they have not been involved in the decision making process. The main drawback of the authority decision is the advantage of the group decision. When people are involved in a decision making process, they can identify with the solution. As a result they tend to support and execute the decision in their work place.

## **CONCLUSION AND FINDINGS**

The managers have treat their employees in the same way as their external customers, as internal satisfaction is a prerequisite for external performance. If the internal encounters are unsatisfactory, the external customer may end up dissatisfied and complaining. The managers of service companies have to encompass the various processes into the overall strategic vision, which implies that they have to turn the strategic vision inward. Moreover, they need to equally emphasize both processes within the organization and the overall result of the service operations.

In order to ensure a high employee commitment it is suggested to increase the level of employee involvement. Employees feel much more satisfied with their work if they get a change to influence some of the various everyday decisions, or if they get a sufficient amount of information. They most important job for managers of service organizations is to empower and coach the employees instead of just doing all the work themselves. However, for service companies, empowerment is a question of balance. Giving employees control over their own work processes without loosing the control over them; hence, the real challenge is to provide the employees with self management and authority.

If one of the overall goals of a service organization is to provide their customers with high quality services, then it is of utmost importance for the mangers to build the provision of quality service into the organization's rewards system. The employees need to know exactly what is expected f them, and which activities are the most valuable ones.

In regard to the reward system, the mangers of service companies would benefit from utilizing the full range of available rewards, instead of just making use of payments. Payments are just one way to motivate people, but on the other hand esteem and respect are as well important determinants of a person's performance and should therefore not be underestimated.

## **REFERENCES**

- [1] Statistic Book 2004
- [2] Piercy, N,F, ( 1995): Customer Satisfaction and the internal market, marketing our customers to our employees, journal of marketing practice, applied marketing science, Vol. 1, no, 1,pp. 22-44
- [3] Ballantyne,D., M.Christopher, A. Payne (1994) Improving the quality of service marketing: service(Re)Design is the criticallink, journalof marketing management, Vol.11,no.1,pp.7-24

- [4] Berry, L.L. (1986) : Big Ideas in Service marketing, *Journal of Consumer Marketing*, Spring, PP.47-51
- [5] Fisk, R.P., S.W. Brown, M.J. Bitner (1993): Tracking the evolution of the services marketing literature *Journal of Retailing*, vol. 69, no. 1, pp.61-103
- [6] Bitner, M.J., A.R. Hubbert (1994): Encounter Satisfaction Versus Overall satisfaction Versus Quality: the consumer's voice, in R.T. Rust Oliver (eds.), *Service Quality: New Directions in Theory and practice*, sage Publications, Thousand Oaks, CA.
- [7] Bowen, D.E., E.E. Lawler (1992): Empowerment of service workers: What, Why, How and when ? *Sloan management review*, Vol.33, Spring, PP.31-39
- [8] Gronroos, C. (1990a): *Service management and marketing: managing the moments of truth in service competition*, Lexington Books, Lexington.
- [9] Berry, L.L., V.A. Zeithaml, A. Parasuraman (1990): Five imperatives for improving service quality, *Sloan management Review*, Vol. 31, Summer, pp. 29-38
- [10] Berry, L.L., A. Parasuraman (1999): *Marketing Service: Completing Through Quality*, The Free Press, New York.
- [11] Gilmore, A., D. Carson (1995): Managing and marketing to internal customers, in W.J. Glynn, J. G. Barnes (eds), *Understanding service management*, John Wiley Chichester, England
- [12] Nagel, P., W. Cilliers (1990): Customer satisfaction: a Comprehensive Approach, *International Journal of Physical Distribution and logistics*, Vol.20, no.6, pp.2-46
- [13] Gremler, D.D., M. J. Bitner, K.R. Events (1994): Internal Service Encounter. *International journal of service industry management*, Vol5, no.2, pp.34-56
- [14] Lewis, B. R. (1995): Customer care in services, in W.J. Glynn, J.G. Barnes (eds) *Understanding service management*, John Wiley, Chichester, England
- [15] Rafiq, M.P.K. Ahmed (1993) : The scope of internal marketing: defining the boundary between marketing and human resource management, *Journal of marketing management*, Vol. 9, no. 3, pp. 219-232.

# Marketing Strategies in the Indian Banking Service Sector

NARESH KUMAR<sup>1</sup>, SANTOSH KUMAR YADAV<sup>2</sup> AND VIVEK SRIVASTAVA<sup>1</sup>

## Abstract

*Indian Banks have recorded a phenomenal growth in the past decade with the initiation of Economic Reforms. The banks, both Public and Private, have transformed themselves into profit-oriented business organizations besides playing a developmental role in the economy. In an attempt to be more profitable, the banks have become competitive and more customer-oriented. This new orientation has compelled them to take a more pragmatic approach for conducting the business. Innovation is the key to success for any activity and technology has become the fuel for rapid change. Innovative banking is possible only when we have innovative people in banking. Moreover, innovative ideas of such people have to be heard at the right time by the right people. Only then the needed encouragement and support is given to convert innovative ideas into reality. Indian banking is also changing its shape rapidly by adopting innovative technology products and services,*

*The new technology has radically altered the traditional ways of doing banking business. Technology plays a prime role in improving the internal working of a bank and ensuring customers' satisfaction. It has accelerated Customer –Centric delivery channels services round the clock.*

*The paper focus on new and upcoming technology in baking sector, trends in technology development, tools applicable in banking, impact on service quality of banks etc.*

## INTRODUCTION

Over the years, Indian banks have expanded to cover a large geographic & functional area. They have been managing a world of information about customers - their profiles, location, etc. They have a close relationship with their customers and a good knowledge of their needs, requirements and cash positions. During the period of planned economic development, the bank products were bought in India and not sold. Banks require leveraging existing customer information to gain a deeper insight into the relationship a customer has with the institution, and improving customer service-related processes so that the services are quick, error free and convenient for the customers. Banks need to have very strong in-house research and market intelligence units in order to face the future challenges of competition, especially customer retention. Marketing is a question of demand (customers) and supply (financial products & services, customer services through various delivery channels). Both demand and supply have to be understood in the context of geographic

<sup>1</sup> Assistant Professor, IIMT Group of Institutions

<sup>2</sup> Assistant Professor, Indira Gandhi Technical and Medical Sciences University, Arunachal Pradesh.



locations and competitor analysis to undertake focused marketing (advertising) efforts. Focusing on region-specific campaigns rather than national media campaigns would be a better strategy for a diverse country like India. Customer-centricity implies increasing investment in technology. Throughout much of the last decade, banks world-over have re-engineered their organizations to improve efficiency and move customers to lower cost, automated channels, such as ATMs and online banking.

### **Challenges Facing by Banking Industry**

The banking industry in India is undergoing a major transformation due to changes in economic condition and continuous deregulation. These multiple changes happening one after other has a ripple effect on a bank trying to graduate from completely regulated sellers market to completed deregulated customers market.

- **Deregulation:-**This continuous deregulation has made the banking market extremely competitive with greater autonomy, operational flexibility, and decontrolled interest rate and liberalized norms for foreign exchange. The deregulation of the industry coupled with decontrol in interest rates has led to entry of a number of players in the banking industry. At the same time reduced corporate credit off thanks to sluggish economy has resulted in large number of competitors battling for the same pie.
- **New rules:-**As a result, the market place has been redefined with new rules of the game. Banks are transforming to universal banking, adding new channels with lucrative pricing and freebees to offer. Natural fall out of this new players, new channels squeezed spreads, demanding customers better service, marketing skills heightened competition, new rules of the game pressure on efficiency missed opportunities. Need for new orientation diffused customer loyalty. Bank has led to a series of innovative product offerings catering to various customer segments, specifically retail credit.
- **Efficiency:-**This in turn has made it necessary to look for efficiencies in the business. Bank need to access low cost funds and simultaneously improve the efficiency. The banks are facing pricing pressure, squeeze on spread and have to give thrust on retail assets.
- **Diffused customer loyalty:-**This will definitely impact customer preferences, as they are bound to react to the value added offerings. Customers have become demanding and the loyalties are diffused. These are multiple choices; the wallet share is reduced per bank with demand on flexibility and customization. Given the relatively low switching costs; customer retention calls for customized service and hassle free, flawless service delivery.
- **Misaligned mindset:-**These changes are creating challenges, as employees are made to adapt to changing conditions. There is resistance to change from employees and the seller market mindset is yet to be changed coupled with fear of uncertainty and control orientation. Acceptance of technology in but the utilization is not maximized.
- **Competency gap:-**Placing the right skill at the right place will determine success.

The competency gap needs to be addressed simultaneously otherwise there will be missed opportunities. The focus of people will be doing work but not providing solutions, on escalating problems rather than solving them and on disposing customers instead of using the opportunity to cross sell.

**Strategic options with banks to cope with the challenges:** - Leading players in the industry have embarked on a series of strategic and tactical initiatives to sustain leadership. The major initiatives include:

- Investing in state of the art technology as the back bone of to ensure reliable service delivery.
- Leveraging the branch network and sales structure to mobilize low cost current and savings deposits.
- Making aggressive forays in the retail advances segments of home and personal loans.
- Implementing organization wide initiatives involving people, process and technology to reduce the fixed costs and the cost per transaction.
- Focusing on fee based income to compensate for squeezed spread.
- Innovating products to capture customer 'mind share' to begin with and later the wallet share.
- Improving the asset quality as Basel II norms.

**Innovative Marketing approach:** The new marketing approach becomes an imperative for businesses to formulate their Marketing activities and to build relationships, networks, and interactions with, a number of different, but often equally important markets. The customer market is the key market and the importance for a business of retaining its customers, with evidence suggesting that retention of customers leads to increased market share and eventually bigger profits. Marketing tools that businesses can employ for retaining customers may provide for a competitive advantage. CRM-oriented businesses market their products and services through relationships and interactions with multiple markets, most notably the customer market. The bank has chosen to combine external and internal information in order to build an effective and efficient segmentation. The important elements to consider for segmentation are the consumers' attitude and needs; socio- demographic situation; actual and potential profitability; and behavior in terms of distribution channel use and products. An excellent segmentation will also enable the bank to find and focus on consumer who will be considered as referrals by others. Their recommendations of the bank will be taken seriously, and the potential future client base widens. The bank has identified five groups according to their risk level, distribution use, revenues, interest in insurance, and socio-demographics. Few banks have already started marketing aggressively for retail business loans by tying up with a select-reputed builders and conducting road shows in India and abroad to lure the salaried people and professionals. This role of intermediation of the banker between the builders and salaried people and professionals can be further extended to cover other areas as well. For example

banks can connect the manufacturers of goods and services with the ultimate buyers. The process is very simple. Banks are required to have a common agency with which the entire database of all the banks should be shared. This data should be analyzed and classified into various segments say- according to activity, age, place, income, education, etc., of the organizations and people who constitute this data. Few relaxations in the existing banking laws are required for this purpose. Banks can also play an active intermediary role in connecting the organizations and people at various segments, thereby facilitating the process of movement of goods and services from the manufacturers/producers to the ultimate users (of course through other intermediaries where they are not dispensable). Banks can finance the manufacturers/producers or the ultimate users while tying up them with one another thereby increasing their lending portfolio and in the process ensuring the end use of funds. Collection of data from rural places is one area where banks can boast of possessing rich information, especially the public sector banks that have almost more than one third of the network of branches located at rural areas. Banks can play a dynamic role in the delivery and purchase of consumer durables to the rural sector by using their rural database. Therefore, instead of acting as financing intermediaries to some of the parties in the total chain as at present, banks can bring all the parties in the chain under their ambit. Banks can thus transform themselves into aggressive marketing intermediaries from mere financial intermediaries. This innovative approach can also be used with regard to NPAs where the products manufactured by such sick or loss-making units are of good quality but the units have become sick due to financial indiscipline or mismanagement or lack of marketing skills. Buyers for such products can be scouted by the banks by using the above mentioned database and in deserving cases buyers can be given bank finance or their own merits to buy the products of sick units. A portion of the funds thus given can be again routed back into the banks for their working capital requirements. Similarly, banks can play an active marketing role in venture capital financing with the above modus operandi, thereby taking part in not only financing the venture capital but also in marketing functions. Micro finance is yet another area where banks can play an active role. The objective of micro finance is to deliver a wide range of financial services say, deposits, advances, insurance and other related products to people engaged in agriculture, small enterprises and poor people in order to increase their standard of living. Finance is extended to SHGs or NGOs, which is basically institutional/group finance instead of lending to individual beneficiaries unlike in the case of other priority sector/rural lending. Moreover, there are no subsidies or interest concession and the basic concept in micro finance is to give a timely finance to the needy people. Therefore, transaction costs are cheaper and profitability is better under micro finance when compared to the conventional rural lending. In view of these factors in the long run micro finance is likely to replace the conventional and concessional rural lending. Ample scope is available for private and foreign banks to venture into this activity due to the above-mentioned advantages. Similarly, banks in rural sector should actively market products like Kisan Credit Cards, Forward, Futures, and Option markets of commodities. While Kisan Credit Cards serve as an instrument of credit, Forward, Futures and Options markets ensure a fair price to the farmers eliminating uncertainty. However,

this require an effective network that is one regulated as well as a matured financial market in rural areas for the growth and development of these products. Rural India and its economy mainly depend upon Monsoons. Famine and Floods both occur at the same time in the different parts of the country causing damage to the crops. Therefore, rural insurance has to be an effective tool in hedging these risk factors. Government, banks and insurance have to together evolve a more proactive and vibrant measures to deal with this issue, both at macro and micro level. There is a vast untapped potential in this area and lot of scope for developing new and innovative insurance linked financial products. Merger of developmental financial institutions like ICICI and IDBI with their commercial banking wings lays emphasis on universal banking offering wide range of financial products under one umbrella. Similarly, SIDBI and NABARD are having a strategic alliance with few commercial banks to expand the reach of their products and services.

**Marketing Approach for Urban Areas:-**The urban areas of India are developed. The level of income of the people, the literacy rate and level of education as well as awareness of the people about rights of the customer are higher than that of the rural and even semi urban areas. Thus for effective bank marketing different approach is necessary than that of rural areas. Under competitive environment for the success of the business, better customer service is play an important role. Attracting new customers and retaining existing customers is possible only with customer service. Use of modern technology in urban areas will also go long way for marketing of banking services. Technology based service like credit card, debit card, ATM; anywhere banking, internet banking, and mobile banking are necessary for urban areas. To attract business and wholesale customers, banks need to adopt technology based product and service which is suitable to urban customer. In urban areas the extent and variety of economic activities demands that one institution should meet all financial need of a customer. Under such an expectation of people, universal banking would prove successful approach for bank marketing. The idea is to conduct banking and allied activities under one roof. Such allied activities may include credit cards, asset management, housing finance and insurance, all of which are run concurrently with core banking operations. Modern banking is heavily depending upon retail banking. To attract retail customer this approach is ideal.

**Marketing Approach for Rural Areas:-** Prior to nationalization of banks, the rural areas were virtually without banking facility. After nationalization of banks in 1969, branches of the banks were started gradually in the rural areas also. In different state the extent of rural banking is different. Some of the states have good performance in the rural banking but in spite of that unorganized sector is still dominating in the rural banking. It means the nature of competition is different. Here banks have to face competition with the unorganized sector. Under such environment different marketing approach is required. For effective rural marketing, Product development, Promotion and Communication play an important role. All these parameters banks have to balance with socio-economic factors prevailing in the rural areas. Here bank need to innovate product that could attract the depositors. Various loan schemes that are suitable for them for getting funds at right time and also they find convenient to repay. For loans and advances products which are suitable

to farmers, small traders, small scale agro based rural industries are already in existence. Banks need to see that how value addition can be made to these existing schemes. Banks also needs to tie up with Non Government Organizations (NGO) and Self Help Groups (SHG) for different types of loans, micro financing etc. This will help the bank for building good image and reputation in the rural areas. Marketing through customer services in rural areas is different from that of urban areas. Because of high level of illiteracy people prefer to undertake banking transaction themselves. For effective marketing in rural areas bank should have staff with right soft skill like concern for customers' problem, positive attitude, good communication and negotiation skill. At every level of dealing with the customer bank need to educate them for banking activities and processes.

**Marketing Alliances and Tie-Ups with Different Sectors:-** To boost its business, Banks entered into several alliances and tie-ups with automobile, insurance, mutual fund, project finance and medical equipment companies. For example, SBI entered into a tie-up with Maruti, the largest automobile manufacturer in India, to provide loans for purchase of Maruti cars at the rate of 10.05 per cent and 11.25 per cent for three years and above three years respectively, 2007.

**Bank Marketing Strategies:-**The marketing research considered being a systematic gathering, recording and analysis of data makes ways for making and innovation the marketing decisions. The information collected from the external sources by conducting surveys helps bank professional in different wants. In the bank services, the formulation of overall marketing strategies is considered significant with the view point of tapping the potentials, expanding the business and increasing the marketing share. The increasing domination and gaining popularity banks, the popularity banks, the profitable schemes of the non-banking organization mounting craze among the customers for private banks have made the task of influencing the impulse of customers a bit difficult. The marketing research simplifies the task of studying the magnitude of competition by opinion surveys and the feed back customers, the multi-dimensional changes in the services mix can be made productive if it is based on marketing research.

**Customer Service Strategies in Banking Sector:-**Today, banking sector is seen as a catalyst in economic growth of a country and, lot is expected from the banking fraternity. The recognition of banking, as a tool for all inclusive growth by economists, financial planners, reformist etc has made it an important sector in the Government's planning of economic growth. The banking sector in India is therefore witnessing tremendous changes because of political, social and economic changes that are taking place domestically and internationally. ATMs of the larger banks are either fully out sourced by the individual banks or handed over to an autonomous agency by most of the banks collectively. Small players in ATMs are also trying to be a part of this shared network with regard to clearing operations, Reserve Bank of India has already initiated the required steps to gradually dispense with the physical presentation of chques and replace the same with electronic clearing in major cities. Similarly the audit and inspection of the computerized branches is now being done in many cases by transfer of data files to the supervisory

and inspecting authorities. Qualitative inspection and supervision of the banks by Reserve Bank of India is made possible by the technology, leaving the routine audit work to the concerned internal audit departments of the individual banks. With the automation of the routine work process and rapid technological developments, a host of customer friendly banking products with flexibility are now available to one and all. Few departments of the government (e.g. customs, income tax, central excise, commercial taxes and sales tax) have already initiated the process of EDI (Electronic Data Interface) there by reducing the manual tasks in the preparation of documentation and enhancing the levels of automation. This also facilitates standardization in documentation with uniformity. This will also ensure submission of such standard data in electronic form and scanning the physical documents where required. In the long run, this enables e-commerce to gain momentum. Therefore, banks can also equally look forward to submission of commercial documents by the trade industry through EDI in the near future. Once this is done, the need for the business segment to personally visit the bank branches to submit the documents will be eliminated. When ATMs on one side have reduce the depends of individuals customers on the bank branches to conduct their routine banking operations, the EDI when gains momentum will reduce the dependence of corporate customers on the bank branches in a similar fashion. These developments taking place mainly on account of automation will reduce the differentiation in the service delivery systems, as they are mostly standardized. Therefore, banks have to be innovative to maintain their brand values. The concept of banking, which was earlier restricted to accepting of deposits from public for the purpose of, has also undergone sea change. Today the banking sector is seen as a vehicle for all inclusive economic growth, social responsibility and equiv-distribution of national resources. Today banks are wooing existing customers, prospective customers by offering new facilities, products, and services in order to retain/increase their base in market. The way the banking has changed, so has the customer changed. The customer of today is not what he was yesterday. Today the customer is more knowledgeable, demanding, analytical and aware of his rights. It is therefore a challenging task before the banking sector to revisit their entire working modules, up gradation of skills, technology, and policies so that they are competent to withstand the international competitive environment in future. All customers from different backgrounds have different expectations. Unless the service standards fit to each person's expectations, he will not be satisfied. Therefore one has to understand each type of customer thoroughly to be able to provide customer specific services. The entire process of customer service is dependent on following.

**1. Human Resources:-**Any organization's success or failure is the result of success or failure of its employees collectively. Here the employee doesn't mean only the staff working down the ladder, but also includes people right up to the top. All the functions in an organization are undertaken by humans, whether it is selection of staff, development of product, making software, formulating policies, devising systems, procedures, defining processes, delivery channels, undertaking market studies etc. Humans may be assisted by the technology for arriving at the decisions. In all the functions enumerated above, different departments do the work separately but the same are ultimately linked to each

other to achieve the corporate goal. It is just like gears though rotating independently, move the entire structure in the desired direction. If any gear malfunctions, it brings the entire process to halt. Thus the human beings working in an organization are very important. Handling of humans by humans is a very complex job also.

The job requirements of HRD are to select, train, develop, deploy, and motivate the human resources in the organization so as to get optimum results for the organization.

**2. Products/services:-**Banks do not provide physical goods to its customers. The products which a bank offers are mostly financial products and along with these products also provide other services which are not financial in nature, like safe deposit vaults, Locker facilities etc.

In financial products there are basically two types of activities, namely deposit procurement and its deployment profitably. These two activities constitute more than 80% of banking business in all the banks.

- I. Deposits:** Basic structure of deposit is to attract the customer by offering interest on funds or some facility in lieu of interest. However depending upon the needs of different set of customers various types of deposit schemes are formulated. For example, savings bank accounts are for those who want short term savings with liquidity and to make regular deposits and withdrawals etc. Term deposits are for those who want to invest for longer duration having surplus funds not needed immediately. Some may want savings to grow gradually by contributing smaller amounts at set intervals. The ultimate goal of depositor is to keep his money safely in the bank and be able to use when needed. Likewise there are various combinations of deposit schemes based on liquidity, returns and safety.
- II. Advances:** Banks, in a similar way deploy deposits by lending to those who need it at a cost in the shape of interest. Here again the products differ depending upon the need of the customer. It may be overdraft facility, working capital finance, term loan, etc for business or personal needs.
- III. Other products/ services:** Apart from deposit and advances, banks offer various other facilities/services to their clients, like remittances, investment services, fund management, financial advisory services, tax collections, bill payment services etc. to earn fee based incomes. The flexibility of banks to adopt changing needs and expectation of customers and bring out products/ services to suit customers is an important area in banking services. A robust Research and Development department which can effectively and efficiently bring out newer products/ services based on market feel and futurist visualization of customer preferences is an important aspect in banking services.

**3. Processes:-**Today's customer is short of time and feels uncomfortable when the process involved in getting the product or service is lengthy and cumbersome. The customer wants very simple processes to get his work done. The processes for any product or service should be at the minimum and at one go. Frequent back references and repeated

information and excessive documentation dissatisfy the customer. The processes devised for getting the services should be very customer friendly, easy to understand and complete. The forms, applications, documents should be simple, easy to understand with proper column and space to write. Sometimes it is observed that the space provided for writing is very small. The quality of paper, the font size and the language should be proper.

**4. Delivery Channels:-**Customer satisfaction is also dependent upon the delivery channels used by banks in providing the services. Today's customer wants effortless, efficient, secure, simple and dependable channels of delivery, whether it is through humans or technology driven channels. To quote an example, suppose a customer uses internet banking and made a third party payment. He would like to know what happened to his payment instructions. He should be able to track the payment on line till it reaches the beneficiaries account. If this facility is not available, he may not be comfortable with the internet banking. Another thing mostly observed in Public sector banks is that their websites are not updated regularly and navigation is very tardy. The forms/ applications are scanned and cannot be filled on line. The information/ forms etc. are outdated and not properly tagged.

**5. Customer Feedback and Complaints:-**Feedback from customers is of immense help in formulating products, fine tune services and plug the loopholes. However most of the time, feed backs are generally not available and public sector banks are normally not enthused about taking feedback on their services. Rather wherever a customer gives his feedback (read complaint), it is not taken in right spirit by the bank/ concerned staff. Instead of looking into the real cause an effort is made to provide alibis or blame the staff. It may be possible that that the procedure itself is the cause of complaint or it is because of reasons which are not under control of the branch.

Customers may be of three types. One type of customer never complains and continues the relationship. Second type of customer does not complain but changes the bank silently and third type of customer complains. First and second type of customers does not give an opportunity to bank to improve upon its services. Third type of customer however gives opportunity to the bank to improve the service though he may not be preferred over the other two types of customers.

Today no bank is willing to accept complaints from the customers and normally effort is made to somehow get the complaint withdrawn or resolved without analyzing why the complaint has originated. It becomes very difficult for field level staff to get the complaint redressed when the cause or reason of complaint is not because of them. However they are made to beg the customer to give satisfaction letter. Each complaint when made may be because of so many factors, not necessarily the fault of the person or branch against which it is made. It may be due to system lapse, procedural deficiency, inapt technology, poor in-house work allocation, work flow module etc. Sometimes the complaints are frivolous and made to harass the person concerned. Though in customer oriented markets, customer is always right but care should be taken that the staff is also protected from frivolous complainants. Each complaint of the customer should be properly analyzed, assessed. It



may be possible that route cause may be somewhere else which should be rectified rather than the concerned staff or branch made the scapegoat.

**6. Grievances Redressal Mechanism:-**Improving upon the services is an ongoing process. The essential inputs are customer feedback, market surveys and the complaints received by an organization. No organization can say that they have zero customer complaints. However an organization which has robust mechanism to redress the complaints and resolve problem of the customer gets recognition as a customer friendly organization. Accepting the mistake and offering compensation goes a long way in retaining the customer. Most of the banks have come out with their compensation policies and customer grievances cells. However they are mostly on paper and seldom followed in the spirit in which they are framed. Even where the compensation policy provides automatic payment of compensation, interest in case of delays etc., it is seldom paid unless the customer demands it.

**7. Market Studies:-**Market studies are effective tools to study the behavior of customers and their response to present standard of services. It also helps to understand future trends and requirements as needs of the customer's keeps of changing with change of times. Market research gives way to innovations in products and services. Market studies may be done in-house, or assigned to outside expert agencies or both depending upon the vision of the bank.

#### **Use of Internet in Banking Industry as a Marketing Tool:-**

Internet is a network of networks. It is not a single network, but a global interconnected network of networks providing free exchange of information. It implies the most pragmatic use of information technology as medium of universal communication. It has brought unprecedented changes in society. Spanning the entire globe, the Net has redefined the methods of communication, work, study, education, interaction, entertainment, health, trade and commerce. The versatile facilities and opportunities provided by the Internet and World Wide Web led to the development of electronic commerce. This became possible when the Internet transformed from the ordinal system providing static web pages, into interactive two-way system. **E-banking** and electronically providing financial services are branches of electronic commerce. A significant development has been achieved in offering a variety of new services in banking sector. **Corporate Internet Banking (CIB)** facilitates banking from your desk. At the click of a mouse, we can access your accounts at any branch of the bank and also keep track of your accounts at its numerous branches.

#### **CONCLUSION**

In the present scenario of competitive banking, excellence in customer service is the most important tool for sustained business growth. Customer complaints are part of business life of any corporate entity. Customers, who take time to complain, still have some confidence in the organization. As a service organization, customer service and customer satisfaction is the prime concern of the bank.

**REFERENCES**

- [1] Johari and Jauhari(1994) Role of computers in banking Operation System, Himalaya Pub. House ,New Delhi
- [2] Kalakota ,R.(2000)E-Business ,Pearson Education ,Asia  
<http://www.iibf.org.in>  
<http://www.rbi.co.in>
- [3] Avasthi,G.P.M(2000),Information Technology in Banking :Challenges for regulators, prajnam, Vol.XXIX, No.4
- [4] Bajaj,KK ,(2000)Ecommerce Issues in the emerging Hi –Tech Banking Enviornment ,The Journal of the Indian Institute of Banker ,Jan-March
- [5] Audrey Gilmore, (1990), "Services marketing and Management", TMH
- [6] D. Ghosh Roy (Dec2002), "Service Quality Management in Banks". BDP Publishers
- [7] B.R.Parthasarathi (Nov.2005), "Customer Service in Banks and its importance", Excel publisher
- [8] Shyam Ji Mehrotra (April 2006), Bank Marketing, Phb publisher  
[www.nabard.org](http://www.nabard.org)  
[www.financialexpress.com](http://www.financialexpress.com)
- [9] Mr Naresh Kumar,Assistant Professor, IIMT Group of Institutions
- 10] Mr Santosh Kumar Yadav, Assistant Professor, indira gandhi technical and medical sciences university, Arunachal Pradesh
- [11] Mr Vivek Srivastava, Associate Professor, IIMT Group of Institutions

# Content Based Information Retrieval System with Special Reference to e-Governance

PIYUSH GUPTA<sup>1</sup> AND SUSHIL KUMAR MAURYA<sup>2</sup>

## Abstract

*Knowledge integrity and sharing is a major challenge in corporate sector. Knowledge source is not possible without authentic and secure information in sectors like banks, research organizations, and health sectors. Due to constrain in knowledge sharing an organization limits the growth in different sectors creating loopholes in data centers and personal knowledge flow. Session management and data print technique applied helps in faster information retrieval. Information managed on different sectors like data center, cloud storage and local disks, minimizes the efforts during retrieval, enhancing personal and organizational growth with e-governance. Being knowledge and information sharing is still in its puberty in corporate sectors, e-governance shall contribute towards better prospects.*

*The paper focuses on human information storage and retrieval, e-governance, and challenges faced during information storage, precautions utilized prior to data storage, information retrieval process and conclusion including future enhancements.*

**Keywords:** Data Center, Cloud Storage, Knowledge Integrity, Data Print Technique

## INTRODUCTION

Human brain is a major source having capacity to store large amount of data, process it and convert it into knowledge base with the help of experience. Once experience is gained using tacit and explicit knowledge, the traces are maintained in permanent memory with the help of chemical conversion in human body using neurons and spinal system. A known psychologist *Elizabeth Loftus* proposed 3 different theories regarding information and knowledge management and retrieval which shall be summaries as follows. The concept remains the same with machines, encoded in binary and logical form for said purpose.

## Decay Theory

A brain cell (neurons) tends to decay in the time process if not utilized, loosing information, and are not available for regeneration in the process of evolution unless replaced.

---

1 Research Scholar, Computer Science, Teerthanker Mahaveer University Moradabad (UP)  
E-mail: Inirmal1709@rediffmail.com

2 Asso.Professor, MIMT Gratter Noida (UP)

### **Interference Theory**

Proactive memory tends to interfere with retroactive memory creating confusion. Old people/memory faces a problem while learning new concepts as neurons does not support new memories. On the other hand new information interferes with ability to update.

### **Failure to Store**

Even though we have information, it may fail to transform into knowledge base. As a result data/information is not stored.

### **E-GOVERNANCE**

It comprises of *Information and Communication Technology* (ICT) to support public services, government administrations, democratic process and relationship among citizens, civil society, private sector and state. The contribution made through e-governance helps in enhancing and reorganizing knowledge resources, supporting overall national growth.

### **CHALLENGES FACED DURING INFORMATION STORAGE**

#### **(DOS) Denial of Service Attack**

Whenever a data is being transmitted from VSAT having a transmission capacity of 1TB /min, considering an ideal transmitting device, storage capacity and with required RPM (*Rotations per Minute*). The terminal may deny the service of data acceptance by hiding its own identity.

#### **Low on Memory**

Data collected from weather forecast, if tried to save on local disk shall be a failure due to low of disk space. In the other scenario whenever a request is fulfilled from the server returning huge file, the connection pauses due to low cache memory loosing data packets. The data packets are retransmitted multiple times within 4 minutes to fulfill the request. Hence time consumed for a query is 4minutes.

#### **Failure to Store Due to Lack of Power Management**

Human being is also a part of information retrieval system as major processing of content selection is done by the user. some time humans do make mistakes by not providing a power backup to the terminal denying request. It is a day today experience that power failure during file download looses information and may lead to bad data sectors on the data disk.

#### **Permission Not Granted**

As storage medium on data center, cloud storage or on local medium including RAID (*Redundant Array of Independent Disks*) device, does not have write permissions, then data cannot be written on the disk, again loosing the data packets.

### **Data Packet Loss on Distributed Database**

When it comes to big data or data centers, information needs to be written on distributed database for security, data integrity and retrieval. Data packets may lose information due to network failure, DOS attack and so on.

### **PRECAUTIONS PRIOR TO DATA STORAGE**

Even though information retrieval from data centers or cloud storage is a major issue, but how the data is being stored on the storage medium matters. The query continues with where the medium lies? What are its RPM? Does it have full access? Last but not the least is it networked properly like in case of RAID devices for enhancement.

Following approaches are proposed for better information retrieval from big data and data centers.

### **Weighing Approach**

Google being one of the best search engines in India uses text based approach to retrieve data, based on the user request. The URL (*Uniform Resource Locator*) displayed as a result of a query, does not guarantee the content required. The search engine locates the content based on the weight of data. Unique keywords in text, use of hash key, simple and unique name of website or file, registered and upgraded with online system helps to improve the weight of a document.

### **Automated Indexing Algorithm**

MBR (*Master Boot Record*) is the best example to understand automated indexing. The MBR lies on the *Hard Disk Drive* (HDD). It helps in maintaining the partition details on the disk. The track and sector details can be tracked using MBR. It also keeps information about first boot sector utilized by operating system. When it comes to data centers RAID drive can be used with parity drive for automated indexing. In case of big data or the cloud technology, distributed parity drive with concerned application shall help in automated indexing of huge information.

### **Database Crawler Network**

Database containing more than thousand tables are much easier to crawl within the tables to retrieve the information. To enhance the speed of information retrieval process, a crawler shall be designed which have a potential to extract content from the files irrespective of file formats. Once done, the crawler creates database network with head and tail node. While searching for the information in database based on the query, head node of network is given as an input. The database network graph is saved in knowledge base. With content based approach the graph generated may be longer in size. To overcome this problem stemming algorithm shall be used to minimize the size of a graph.

### **Finger (Data) Print Generation Technique**

This is one of the best approach to keep a track of different shared resources within data network. An attached hardware resource or terminal shall be a part during graph generation. The finger prints are generated from header files from the connected sources which shares a details like time stamp, IP address of a terminal, protocol used, how long the session last and shared data packets. Using finger print technique number of input and output resources shall be kept in control, and have important role to play in knowledge base generation.

### **Session Management During Data Storage**

When it comes to information from banking and medical sector, data integrity and security plays very important role. The transactions are managed using secure sessions. image creation is possible by using mirror disk and parity drive for faster transactions. All these secure sessions shall be utilized to be a part of knowledge base with concerned application software.

### **Data security**

Database hacking, phishing attack and similar intrusions attacks are a part of day today life. Solution without security for a concerned problem is in vain. Hence information security is maintained using available encryption process and by using security tools at data centers and cloud storage.

## **INFORMATION RETRIEVAL PROCESS**

The proposed process is an extension of information retrieval life cycle from *Dr. Singh*. As per his view, a query is being fired on database by the user, which searches information based on ranking of documents in large database.

I would like to propose that, information retrieval is more efficient in large data centers and cloud base approach by using divide and conquer approach. Before storing the data on the efficient medium, set the agents which shall automatically manage sessions, finger /data print approach, efficient and intelligent crawlers to walk within huge databases, and database network with security. The gained results shall be combined and given to the user, based on the request. The mirror image is kept to design knowledge base for future use.

## **CONCLUSIONS AND FUTURE ENHANCEMENTS**

The proposed information retrieval system in data centers and cloud based computing is not possible without e-governance. The mirror image which is dynamically generated has details about query network, document network, session details with automated indexing process with security enabled. These components contribute towards efficient knowledge base, which shall be dealt as future enhancements in the process of information retrieval. The process depends upon hardware configuration. Efforts shall be made as future enhancement to make information retrieval a hardware and platform independent for efficient information and knowledge retrieval.

## REFERENCES

### Journals/Articles

- [1] Using *linear Algebra for intelligent information retrieval*, M. W. berry, S.T. Dumias, Computer Science Department, 1994.
- [2] *Seven ages of information retrieval*, International Federation of Library Associations and Institutions Universal Dataflow and Telecommunications, Core Programme, Occasional Paper.
- [3] *Simple, Proven Approaches to Text Retrieval*, S.E. Robertson, K. S. parkk Jones, *University of Cambridge*, computer laboratory, Technical Report, No-356.
- [4] *Audio Information Retrieval (air) Tools*, George Tzanetakis, Department of Computer Science, Princeton University Perry Cook, Department of Computer Science and Department of Music, Princeton University.
- [5] *A Taxonomy of Web Search*, Andrei Broder, *IBM Research*.
- [6] *Information Retrieval on the World Wide Web*, Venkat n. Gudivada, Dow Jones Markets, Vijay V. Raghavan, *University of Southwestern Louisiana*, William I. Grosky, Wayne State University, Rajesh Kananagottu, *University of Missouri*. IEEE, Internet Computing.
- [7] *Towards Intelligent Information Retrieval on Web*, Vandana Dhingra et al. / *International Journal on Computer Science and Engineering (IJCS)*, Ms. Vandana Dhingra, Dr. Komal Kumar Bhatia.
- [8] *Human Information Behavior*, T.D. Wilson, *University of Sheffield*, Special Issue on Information Science Research, Volume 3, No-2, 2000.
- [9] *A survey of Concept-based Information Retrieval Tools on the Web*, Hele-mai Haav, Tanel-lauri Lubi, *Institute of Cybernetics at Tallinn Technical University*.
- [10] *Information Discovery and Retrieval Tools*, Michael T. Frame, U.S. Geological Survey, Center for Biological Informatics, USA.
- [11] *Recommended Reading for IR Research Students*, Alistair Moffat, Justin Zobel, David Hawking, CSIRO ICT Centre, Melbourne, Australia.
- [12] *Interaction with Texts: Information Retrieval as Information-Seeking Behavior*, Nicholas J. Belkin, School of Communication, Information & Library Studies, Rutgers University, New Brunswick, nj 08903 USA.
- [13] *The Inquiry Retrieval System*, James P. callan, Stephen M. Harding, MIT, department of Computer Science, USA.
- [14] *Issues and Challenges of Research: Originality Based Document Classification and Information Extraction*, Hussam Eddin Alfitouri Elgatait & Wan Mohd Fauzy, Centre for Instructional Technology and Multimedia, University Sains Malaysia Penang, Malaysia, *International Journal of Scientific & Engineering Research Volume 3, Issue 8, August-2012*
- [15] *Indexing Relational Databases for Efficient Keyword Search*, *International Journal of Scientific & Engineering Research Volume 2, Issue 10, Oct-2011*.
- [16] *Study of Imperfect Information Representation and FSQL Processing*, Kamal Singh, Kundan Prasad, Mahendra Kumar, A.K. Sharma, *International Journal of Scientific & Engineering Research Volume 3, Issue 5, May-2012* .
- [17] *A Novel Approach for Query Recommendation Via Query Logs*, Rachna Chaudhary, Nikita Taneja, *International Journal of Scientific & Engineering Research Volume 3, Issue 8, August-2012*.
- [18] *A Reconciling Website System to Enhance Efficiency with Web Mining Techniques*, Joy Shalom Sona, Prof. Asha Ambhaikar, *International Journal of Scientific & Engineering Research Volume 3, Issue 2, February-2012*.
- [20] *A Personalized Ontology Model for Web Information Gathering by Domain Specific Search*, Shubhangi Shindikar, M.V.Nimbalkar, Anand Deshpande, *International Journal of Scientific & Engineering Research*, volume 3, issue 7, July 2012.

- [21] *Intelligent Information Retrieval in Data Mining*, Ravindra Pratap Singh, Poonam Yadav, *International Journal of Scientific & Engineering Research* Volume 3, Issue 5, May-2012.
- [22] *Combining big data tools with traditional data management offers enterprises the complete view*, Oracle White Paper, 2012.

### **Web Sources**

- [1] [www. Howbigdataisdifferent.html](http://www.Howbigdataisdifferent.html).
- [2] [www. bigdatathehiddenopportunityforbes.html](http://www.bigdatathehiddenopportunityforbes.html).
- [3] [Humaninformationretrieval.htm](http://Humaninformationretrieval.htm)
- [4] [www.memory\\_retrieval.html](http://www.memory_retrieval.html).
- [5] [www.069-c0x.html](http://www.069-c0x.html)
- [6] [The-role-of-information-retrieval-in-knowledge-management-8964.aspx.htm](http://The-role-of-information-retrieval-in-knowledge-management-8964.aspx.htm)
- [7] [www.11croft.html](http://www.11croft.html).
- [8] [www. /ijitkmVol1-1.html](http://www. /ijitkmVol1-1.html)



# Robust Approach of Compressing Images and Analysis of Parameter PSNR, CR with Gamma Effect

SHIVANGI GUPTA<sup>1</sup> AND AVDHESH GUPTA<sup>2</sup>

## Abstract

*Compressing an image is significantly different than compressing raw binary data. If we used general or outdated technique to compression images then result would be not optimal as it should be. This is because images have definitely statistical properties which can be triggered or exploited by encoders which are implemented or design for them. In image we have to give up some fine details for the sake of saving a little more bandwidth or storage space. So we can say that lossy compression technology. In this dissertation compression of digital images are done with the help of DCT. Several encoding technique have also been used together with DCT to improve the performance of compression. A computational analysis of picture quality is also made with respect to compression ratio and PSNR*

**Keyword:** ADPCM, Pixel, Quantization, AC Coefficient, Region Growing, Compressed, Coordinates, Staggering

## INTRODUCTION

An image may be defined as a two-dimensional function, for example let  $f(x, y)$  is a function and it depend on two variable so  $f$  is dependent on independent variable  $x$  and  $y$ , where  $x$  and  $y$  are plane coordinates. We know when we take an image which is function of  $x$  and  $y$  then with help of  $x$  and  $y$  we can calculate the intensity level of image or can say pixel. As we know intensity value lies between 0 to 255. At every point intensity level would be different it depend upon which type of image we fetched. When  $x$ ,  $y$  and the amplitude values of  $f$  are all finite, different quantities, we can call the image a digital or binary form. Digital image processing allows the use of complicated algorithms for image processing, and hence, can offer both more sophisticated performance at simple tasks and the implementation of different approach which would be impossible by analog

---

<sup>1</sup> M.Tech Student, Department of Computer Science and Engineering , IMS Engineering college, Ghaziabad, (UP)

E-mail: gupta.shivangi379@gmail.com,

<sup>2</sup> Associate Professor (CSE), Department of Computer Science and Engineering , IMS Engineering college, Ghaziabad, (UP)

E-mail: avvipersonal@gmail.com

means. In particular, digital image processing is one of the best practical technology for Classification, Feature extraction, Projection, Multi-scale signal analysis. DIP techniques are generally more versatile, reliable, and accurate. They have the additional profit of being easier to analyze or evaluate than their analog counterparts. Specialized hardware is still used for digital image processing: computer structures based on pipeline processing have been the most commercially successful.

## BACKGROUND HISTORY

Nowadays the use of digital imaging is implemented in many applications e.g., object recognition, satellite imaginary, biomedical instrumentation, digital entertainment media, internet etc. The main function of the Digital image processing is to provide the clear picture as per the interest while attenuating detail irrelevant to a given application, and the information regarding the scene is taken out from the improved image. With the help of the digital image processing one can get the reversible, virtually modified image which is noise free and the image is in the form of matrix integers in place of the classical darkroom manipulations or filtration of time-dependent voltages which is necessary for analog images and video signals. Present image processing algorithms are extremely helpful. A digital image, or “bitmap”, consists of a grid of dots, or “pixels”, with each pixel defined by a numeric value that gives its color. . Let us assume that a random variable  $r_k$  lying in the interval  $[0, 1]$  represents the gray levels of an image and that each  $r_k$  occurs with probability  $P_r(r_k)$ .

$$P_r(r_k) = N_k / n \text{ where } k = 0, 1, 2 \dots L-1$$

$L$  = No. of gray levels.

$N$  = No. of times that gray appears in that image

$N$  = Total no. of pixels in the image

If no. of bits used to represent each value of  $r_k$  is  $l(r_k)$ , the average no. of bits required to represent each pixel is

$$L = \sum (r_k) P_r(r_k)$$

## METHODOLOGY

With pace of time there is improvement in technology and there are two type of compression lossy and lossless. Predictive coding is a spatial domain technique. In predictive coding, information already sent or available is used to predict future values, and the difference is coded. Since this is done in the image or spatial domain, it is relatively simple to implement and is readily adapted to local image characteristics.

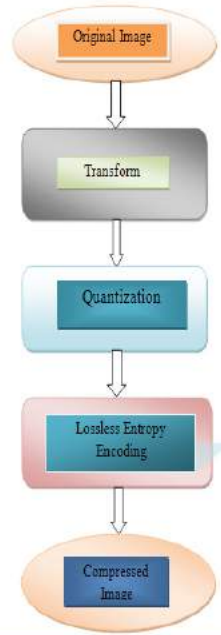

Fig. 1: Encoder for Image Compression

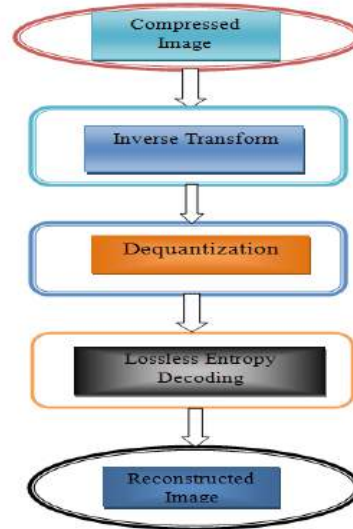

Fig. 2: Decoder for Image Compression

Differential Pulse Code Modulation (DPCM) is one particular example of predictive coding. Transform coding, on the other hand, first transforms the image from its spatial domain representation to a different type of representation using some well-known transform and then codes the transformed values (coefficients). This method provides greater data compression compared to predictive methods, although at the expense of greater computational requirements. We will work over two method of image compression. However both are based on DCT but the encoding technique has been changed. In this section a brief overview of these two approaches is explained with the help of flow chart

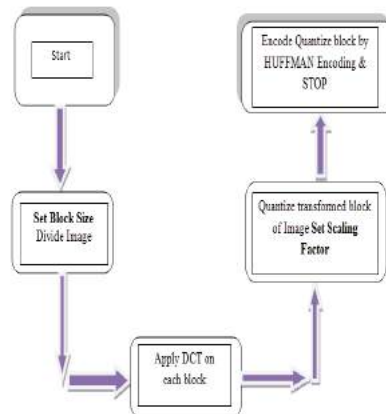

Fig. 3: Flow Chart for DCT Image Compression with Huffman Encoding

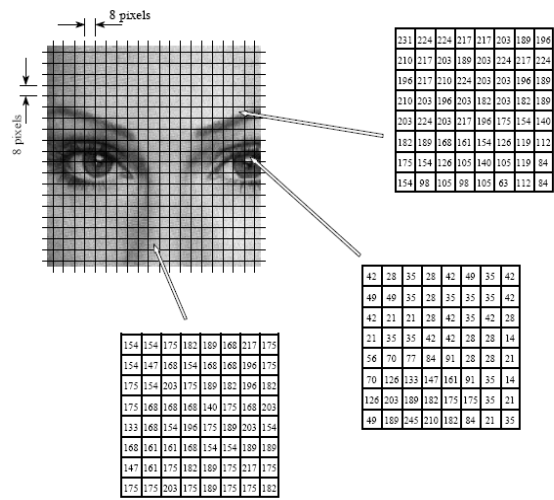

Fig. 4: Division of Image in Blocks

Why use 8×8 pixel groups instead of, for instance, 16×16. The 8×8 grouping was based on the maximum size that IC technology could handle at the time the JPEG standard was developed.

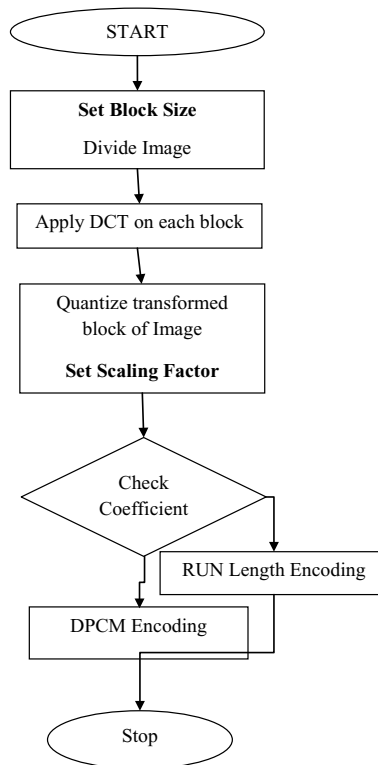
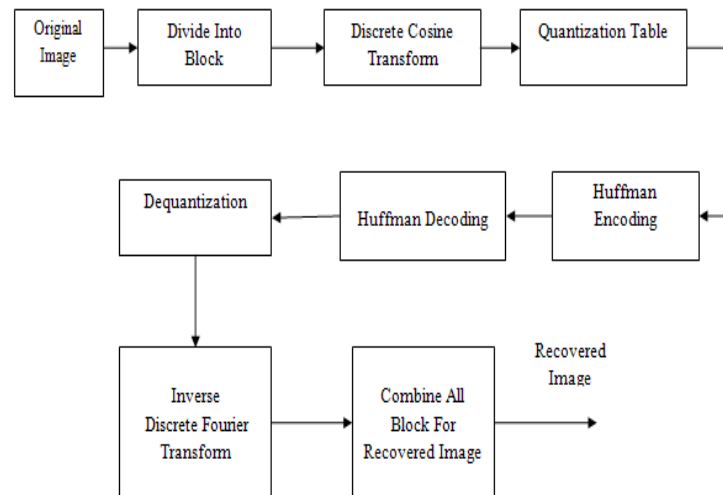

Fig. 5: Flow Chart for DCT Image Compression with RLE-DPCM Encoding

## DCT image compression with Huffman encoding



**Fig. 6:** Block Diagram of DCT Compression and De Compression with Huffman Encoding

## RESULT

We have presented the relationship between the compression ratio and the scaling factor of quantization tables. As we know default quantization table which is universal standard for discrete cosine transform is depicted below:

$$t = \begin{pmatrix} 16 & 11 & 10 & 16 & 24 & 40 & 51 & 61 \\ 12 & 12 & 14 & 19 & 26 & 58 & 60 & 55 \\ 14 & 12 & 16 & 24 & 40 & 57 & 69 & 56 \\ 14 & 17 & 22 & 29 & 51 & 87 & 80 & 62 \\ 18 & 22 & 37 & 56 & 68 & 109 & 103 & 77 \\ 24 & 35 & 55 & 64 & 81 & 104 & 113 & 92 \\ 49 & 64 & 78 & 87 & 103 & 121 & 120 & 101 \\ 72 & 92 & 95 & 98 & 112 & 100 & 103 & 99 \end{pmatrix}$$

We can change the scaling value for different value to analyze the behaviour of different parameter and to access out correlation and regression. Generally we take the range from one to five to derive relationship between CR and PSNR. Now we are going to arrange our simulation result in a fashion such that when we change the value of quality factor in increasing order and due to which we got different parameter variation like DCT CPU elapsed time CR (compression), inverse discrete cosine transform central processing unit time and peak signal to noise ratio. And after that gamma correction result for various images are carried out and region growing result of JPEG image also stimulated. Always keep one thing in mind that these two are applicable for only black and white image. We will see different result obtained from algorithm which we applied on different image.

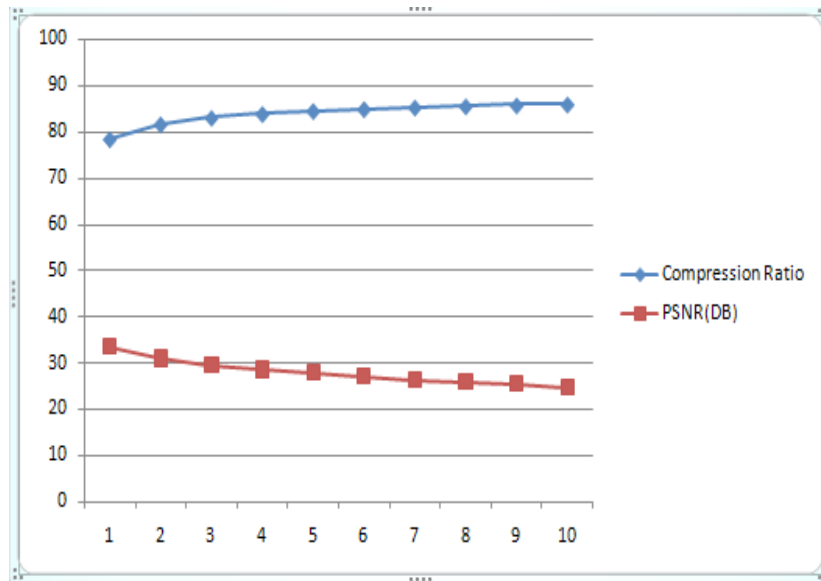

Fig. 7: Graph Analysis of CR and PSNR

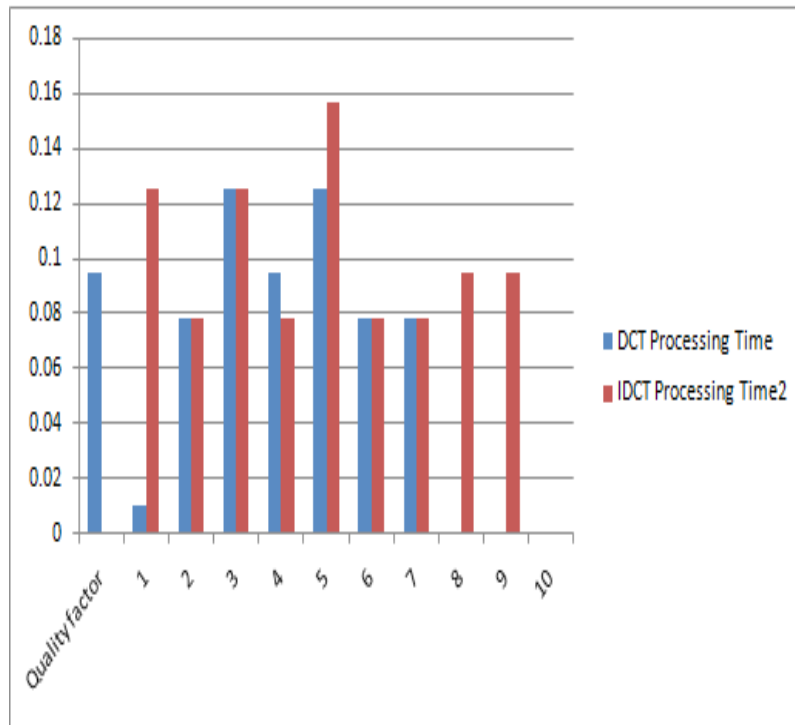
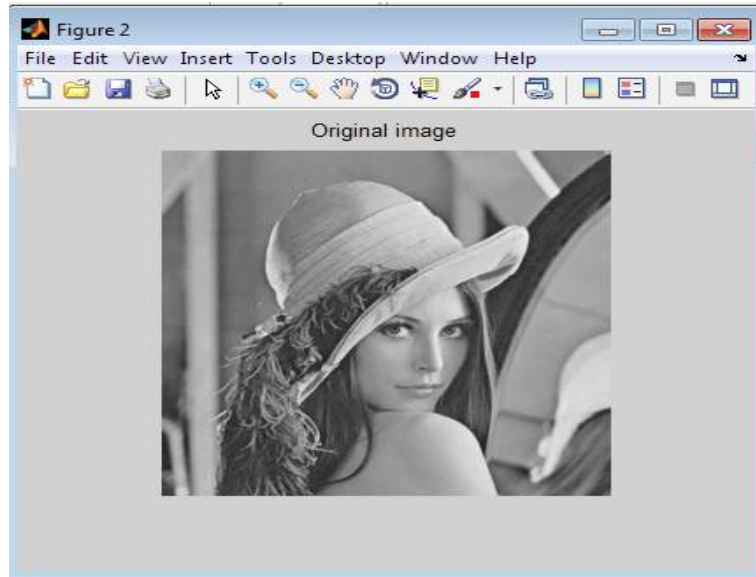
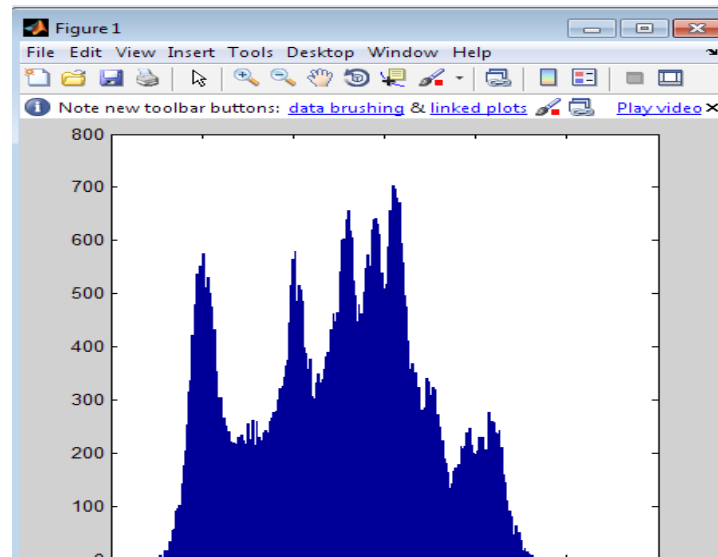

Fig. 8: Graph Analysis of DCT and IDCT Processing Time

In this section we performed lot of experiment with image by changing quality factor value by changing from one to ten and corresponding this we get different result mean to say for each quality factor we got different discrete cosine transform CPU time, compression ratio, inverse discrete cosine transform CPU time and peak signal to noise ratio . From these observation finally we able to conclude a result



**Fig. 9:** Original Image for jpeg Reconstruction



**Fig. 10:** Histogram of Fig.

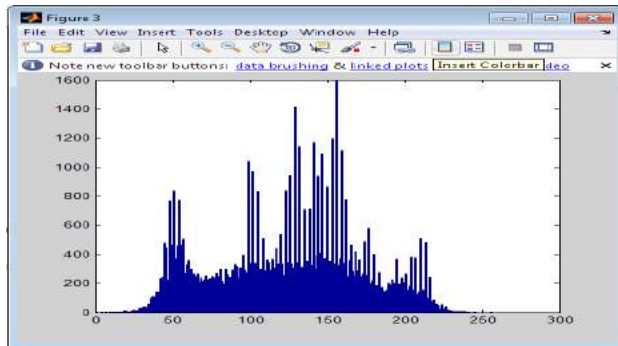

Fig. 11: Histogram Equalization of Fig.

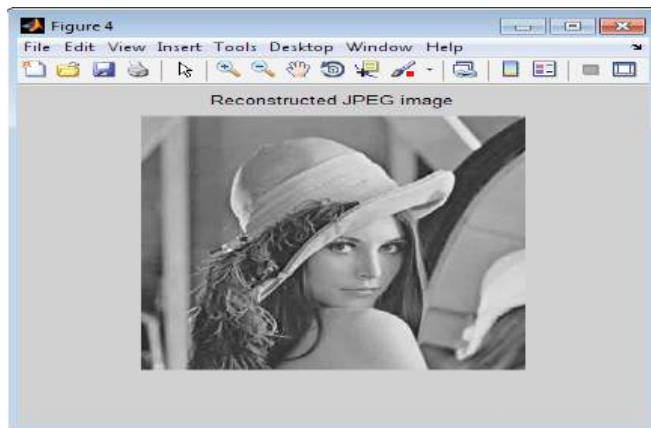

Fig. 12: Reconstructed Image of Fig.

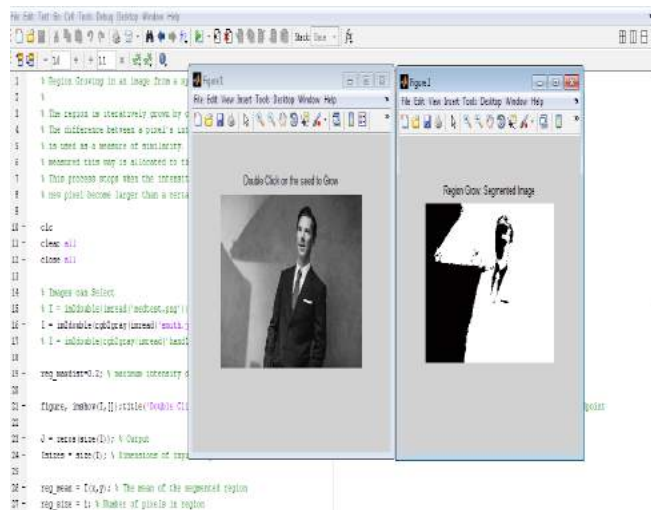
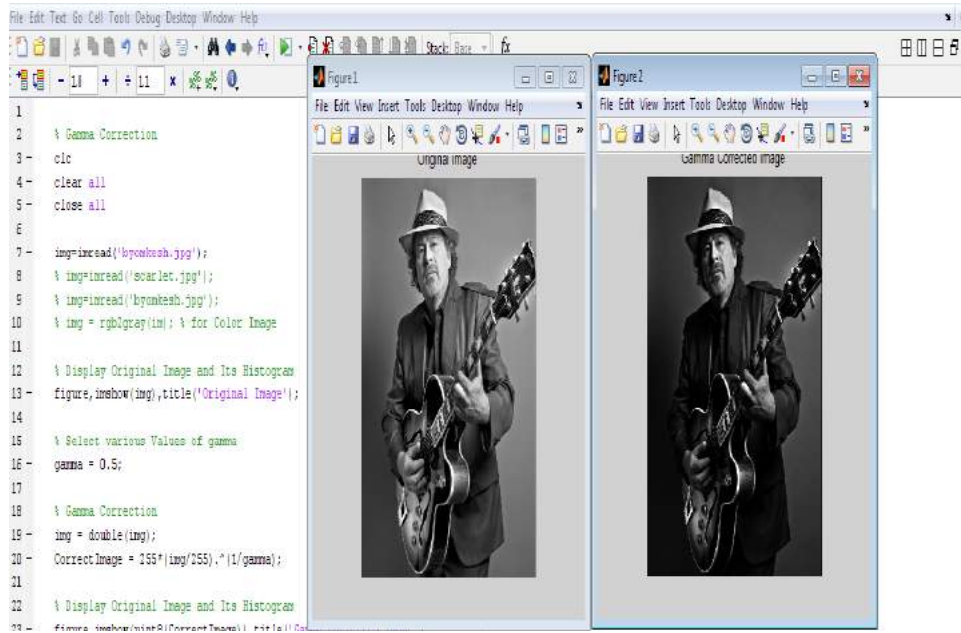

Fig. 13: Simulation Result for Region Growing with Coding





**Fig. 14:** Gamma Corrected Image with Gamma Factor 0.5 with Coding

## CONCLUSION

In this thesis we worked on different field like image compression using DCT. In which we analyze what will be impact of quality factor on image when we will increase value of quality factor value and observe the impact on following parameter for example peak signal to noise ratio, processing time of DCT, compression ratio and processing time of IDCT. As we change the value of quality factor then all these parameters value changes. Now we have to analyse the pattern to carry out a final conclusion. As we increase value of quality factor then image compression ratio will be increased it means that quality of image degraded but size of image will be decreased so that when we have to transmit image over channel or through electromagnetic waves it can be transmitted easily and take less time. One point is very crucial that we did not increase value of quality factor so much high that its quality will be se degraded that at receiver side we cannot access valuable information so over all we can say if compression ratio will be high image quality will be worst so we have to take a trade off between these parameters. On other hand very peak signal to noise ratio is very important parameter. We know PSNR should me maximum for optimize the result. As we increase the quality factor PSNR value reduced in a propotion and we analyze that Compression ratio increased so from this observation we can say that PSNR and CR (compression ratio) both are reciprocal to each other. Besides this we also perform region growing segmentation part and also observed the impact of gamma factor for different images to extract out crucial information and as we changes value of gamma factor then obviously we can clearly see the effect on images.

**REFERENCES**

- [1] Rafael C. Gonzalez," *Digital Image Processing using MATLAB*", 2-e, Pearson Education, 2004.
- [2] Gregory K. Wallace, "*The JPEG still picture compression standard*", IEEE Transactions on Consumer Electronics, Vol. 38, No. 1, pp. 18-36, February 1992.
- [3] Ravi Prakash et.all, "*Enhanced JPEG Compression of Documents*",IEEE International conference of Image Processing, Vol.3,pp.494-497,2001.
- [4] ZiqiangCheng,Kee-Young Yoo,"*A Reversible JPEG-to-JPEG Data Hiding Technique*", Fourth International Conference on Innovative Computing, Information and Control pp. 635-639,2009.
- [5] Weiqi Luo," *JPEG Error Analysis and Its Applications to Digital Image Forensics*" IEEE Transactions On Information Forensics And Security, VOL. 5, NO. 3, September 2010.
- [6] Wei Zheng, ZhisongHou,"*Analysis of JPEG Encoder for Image Compression*" Multimedia Technology (ICMT), International Conference on Digital Object Identifier,pp.205-208, 2011.
- [7] S. V. Viraktamathand G. V. Attimarad ,"*Performance Analysis of JPEG Algorithm*", Proceedings of IEEE Conference on Signal Processing, Communication, Computing and Networking Technologies, pp. 628-633, 2011.
- [8] XiHongZhou ,"*Research on DCT -based Image Compression Quality*", IEEE Conference Cross Strait Quad-Regional Radio Science and Wireless Technology, pp. 1490-1495, 2011.
- [9] HUANGet al. "*Detecting Double JPEG Compression with the Same Quantization Matrix*", IEEE on Information Forensics and Security, VOL. 5, NO. 4, pp. 848-857, Dec., 2011.
- [10] Jing-Ming Guo, et.all,"*Secret Communication Using JPEG Double Compression*", IEEE Signal Processing Letters, VOL. 17, NO. 10,pp. 879-883, October 2010.

# Time Series Forecasting of Some Meteorological Parameters using Statistical Model

GARIMA JAIN<sup>1</sup> AND BHAWNA MALLICK<sup>2</sup>

## Abstract

*Weather prediction is a real time critical issue observed by the world in the last few decades. An enormous amount of the world's population depends generally on the monsoons. In two recent decades, the significant amount of study has been carried out were one of the main concern proposed is water resources issues in the country; and temperature and humidity forecasts can efficiently applied for decision making and optimum usage of water resources. Different models were applied for developing and utilizing of prediction situation, forecasting of the weather data based on different techniques such as Time series. Temperature and humidity have certain effects on hydrologic cycle, production cycle of water consumptions, human efforts and environment. The statistical method is Box-Jenkins model which is used to predict time series. Concept of time series is implemented by two main goals of modeling random mechanisms and prospect of future amounts of series based on its past. During this paper an ARIMA model is used for time-series forecast including measurements of Temperature and Relative Humidity. Results are compared with the performance of an ETS Model. Relative humidity and average monthly temperature are used in present research of 8-year-old statistic. We have compared the models with difference performance metrics, for example, Mean Absolute Error (MAE), Root Mean Square Error (RMSE). The evaluation and parameterization of the ARIMA model have been done using selection criterion Akaike information criteria (AIC) and BIC (Bayesian Information Criteria) in order to forecast average hourly temperature ARIMA (4,1,1) and forecast monthly relative humidity ARIMA (3,1,1) based on Box-Jenkins methodology and after performing validation and evaluation of model, we determined that selection of given models was very proper and forecast of relative humidity measure and average hourly temperature is implemented in a years of 2007-2014.*

**Keywords:** ARIMA (Autoregressive Integrated Moving Average), ETS (Exponential Smoothing), AIC (Akaike's Information Criteria), BIC (Bayesian Information Criteria), RMSE (Root Mean Square Error), Root Mean Square Error (RMSE), Mean Absolute Error (MAE) and Box-Jenkins

---

<sup>1</sup> Galgotias College of Engineering and Technology/Computer Science , Gr. Noida (UP)  
E-mail: jaingarima2011@gmail.com

<sup>2</sup> Galgotias College of Engineering and Technology /HOD (Computer Science), Gr. Noida (UP)  
E-mail: bhawna.mallick@gmail.com

## **INTRODUCTION**

Weather forecasting is crucial issue among the field of meteorology all over the world. Basically we have two different concerns in generating a correct and helpful forecast. The primary is to collect knowledge that are relevant to the prediction task and contain the data that may yield accurate forecast. The second key issue is to decide on a prediction technique that may utilize the data contained within the knowledge and its pattern to the satisfied. There is various techniques concern with weather forecasting from comparatively simple observation of the sky to advance computerized Models [5]. Weather knowledge take into an account have the noises and outliers therefore; the investigation might not be correct. There are mainly three parameters influencing on the climate of a region and leading to continuous droughts which include precipitation, moisture and average temperature. The appliance and important of those three parameters resulted in finding out the fluctuations and temperature changes in future and short term in recent years by meteorological specialists. Weather is taken into consideration as a result of the foremost difficult witnessed by the world among the last decade. Agriculture and plantation area unit the main sector that maintain the economy of the regency. The study make to predict the hourly temperature and relative humidity based on the information of the weather parameters taken on 8 years earlier (2007-2014). Minimum fluctuation in precipitation, temperature and moisture can impact seriously on agricultural and economical parts. Predicting the climate parameters that must be used for long term planning particularly alternatives for combining with disasters. In order for modeling the prediction, one must use stochastic methods and time series analysis. These methods developed fast ideally and practically since 1970 for expecting and control. This analysis is usually related to the data that are not independent and are consecutively interrelated [5]. Small amount of variation in precipitation, temperature and moisture impact extremely on agricultural and efficient components.

### **Outline**

The rest of the paper is organized as follows: Section 2 describes the techniques for prediction using ARIMA Method. Section 3 is used for approaches used for materials and methods and data demonstrations, the models that are examined are also described in Section 3. Section 4 presents and analyzes the modeling and predicting of parameters. Section 5 defined how to predict the values from ETS Model. Finally we summarize the results of research in Section 7. Section 8 describes the related references.

### **Techniques of Prediction Using ARIMA Method**

The main objective of this study is to research a method that develops the prediction of daily most temperature and relative humidity of India. We would like to match the performance of automatic forecasting ways in predicting the weather parameters of India. We have a tendency to try and improve the forecasts by analyzing variable statistic of most temperature along with other variables, which could have an effect on the Temperature and Relative humidity.

### Theory of Time Series Models

Time series is essentially measurement information taken in consecutive order within a certain time [4]. e.g., historical data on sales, costs, number of customers, weather data, etc. The aim of predicting is to estimate how the sequence of interpretations will remain into the future. Univariate time series predicting uses only information on the variable to be forecasted, and makes no attempt to discover the factors which can be a cause of change. Therefore, it will generalize trend and seasonal shapes and ignores all other information. The mostly used univariate forecasting models include ARIMA models and Exponential smoothing (ETS).

Weather Data of India from the dates May, 2007 to March, 2014 was used to provide useful information about the routine of the algorithms. The recorded data from the years 2007-2014 were used to make predictions for forecasting. The precision of various techniques is compared by MAE, MASE, MAPE and RMSE. The criteria AIC and BIC is used for performance evaluation. The methods which gives the optimal result for forecast will use for comparison and prediction. In this paper, ARIMA model is used in R software for forecasting temperature and relative humidity. R is widely used Language which is not only used by researchers but also in diverse time series applications. It also summarizes advanced mathematical and statistical capability to extract analytical knowledge that when organized into existing processes makes them adaptive to improve assumptions [4]. These methods are defined concisely by Hyndman and Khandakar (2008) collection of functions for predicting time series data, as well as many more interesting time series datasets for different functionality. The temperature and Relative humidity data are collected from the Indian Meteorological Department. .

## MATERIALS AND METHODS

### Arima

ARIMA Stands for Auto Regressive Integrated Moving Average. ARIMA model was popularized by Box and Jenkins (1976). This model has achieved well in many real world applications and is still one of the most widely used seasonal forecasting approaches. An ARIMA Model corresponds to ARMA after finitely many times differences the data. The elements  $p$  and  $q$  are the order for Auto Regressive and Moving average Components, because the degree of differencing is given as  $d$ . Differencing is mainly accustomed eliminate the Trend which may Linear and Exponential in a Time Series. This technique finds the standards of the parameters which maximize the probability of obtaining the information that we have determined.

### Methodology for Making the Models

The ARIMA Model can be defined as:

$$Y_{t-1} = a_0 + (1 + \varphi_1)Y_t - (\varphi_1 - \varphi_2)Y_{t+1-p} + \varphi_p Y_{t-p} + \theta_1 Z_t + \dots + \theta_q Z_{t+1-q} + \varepsilon$$

For models with  $p > 0$  and  $q > 0$ , the sample ACF and PACF are challenging to recognize and are of far less importance in order selection than in the special cases where  $p=0$  or  $q=0$ .

A systematic method, however, is still available through minimization of the corrected Akaike’s information criteria (AAA) statistic [2]. In the first stage, the analysis of initial values of p, d and q is determined by auto correlation (ACF) and partial auto correlation (PACF). By precisely revising the ACF and PACF graphs and their components, the overall view for existence of time series with trend and its properties is obtained the corrected AIC is defined as:

$$\rho_k = \text{Corr}(y_t, y_{t-h}) = \frac{y_h}{y_0}, \tag{2}$$

In Second stage, Partial Autocorrelation removing any Linear dependence. The partial lag h autocorrelation is denoted as  $\phi_{h,h}$ . The PACF can be defined as:

**TABLE 1.** Plots of ACF and PACF for ARIMA

**Table 1.** Plots of ACF and PACF for ARIMA

	<i>MA</i> (q)	<i>AR</i> (q)	<i>ARMA</i> (p, q)
ACF	Tail off	Cut off, q lag	Tail off
PACF	Cut off, p lag	Tail off	Tail off

$$\alpha(a) = 1 \tag{3}$$

The model that minimizes the standard is chosen as acceptable for the information criteria.

AIC (Alkies’ Information Criteria) is:

$$AIC = -2(L) + 2k,$$

AICc (Alkies’ Information Criteria Corrected) is:

$$AICc = AIC + 2(k + 1)(k + 2)n - k,$$

$$AICc = AIC + 2(k + 1)(k + 2)n - k,$$

BIC (Bayesian Information Criteria):

$$BIC = BIC = AIC + [\ln(n) - 2],$$

MASE (Mean Absolute Scaled Error<1) defined as:

$$MASE = \frac{1}{m} \sum_{i=1}^m |q_i|,$$

MAPE (Mean Absolute Percentage Error) defined as:

$$MAPE = \frac{1}{n} \sum_{t=1}^n |p_t|,$$

Where

$$p_t = 100 e_t / y_t, p_t = 100 e_t / y_t.$$

## MODELING AND PREDICTING THE AVERAGE HOURLY TEMPERATURE AND RELATIVE HUMIDITY

### Hourly Relative Humidity

There are different steps for predicting the weather parameters by applying Automatic forecasting Algorithm. Firstly we need to recognize the given sequence to make it

stationary for prediction of temperature and relative humidity dimensions, after this we need to estimate the value of different parameters, then we validate the model by regularly fitting it and at last after finalizing all steps the series is use for predicting the future values. The first step is to start with the ARIMA model which finest fits the time-series behavior. With this objective of the autocorrelation coefficient (ACF) and the partial autocorrelation coefficient (PACF) are estimated and depicted below.

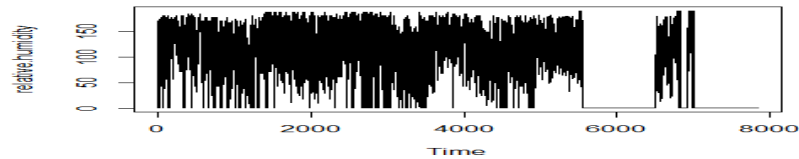

Figure 1. Original Time Series

In this section we explain the technique to reach the optimal model which recover and explain the time-series behavior. In the this phase, the study of initial values of p, d and q is determined by ACF and partial PACF. By making a perfect study on the ACF and PACF charts and their willing components, the general idea for presence of time series with trend and its properties is achieved. The ACF of a giving lag is graphed as:

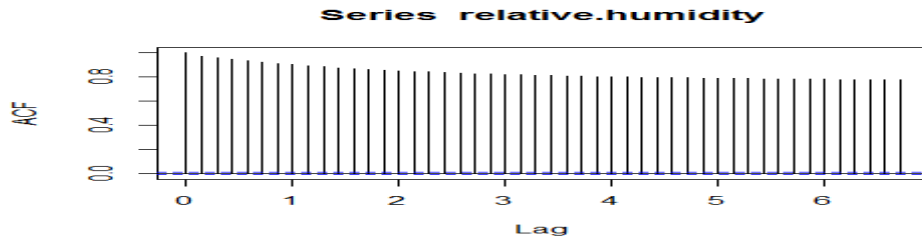

Figure 2. ACF Diagram for Residuals of Relative Humidity

The PACF of a giving lag is defined as:

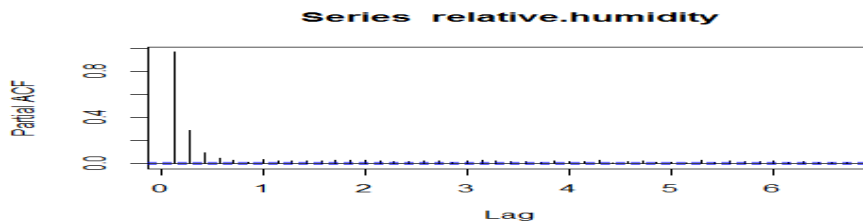

Figure 3. PACF Diagram for Residuals of Relative Humidity

In Second phase, it is evaluated if p and q values, that signify the autoregressive and moving average, it must be removed from and we concluded the ARIMA Model is (3,1,1) is the best model for forecasting the parameters and it is the easiest model to implement and the model with least computation-time, in the forecasting procedure.

**Table 2.** Coefficients of ARIMA Model

ar1	ar2	ar3	ma1	
Estimated	0.6398	0.2029	0.0606	-0.9899
Std Error	0.0044	0.0044	0.0043	0.0010

$\sigma^2$  estimated as 205.2 , log likelihood=-224265.6

The Criteria is given as:

**Table 3.** Criteria's of ARIMA Model

AIC	AICc	BIC
448541.2	448541.2	448585.8

In the case when the evaluated time series is long enough to take in more than a year, then it must be necessary to allow for annual seasonality as well as hourly seasonality is also identified. In that case, a multiple seasonal model such as TBATS is required.

**Forecasts from BATS(0.333, {0,0}, -, -)**

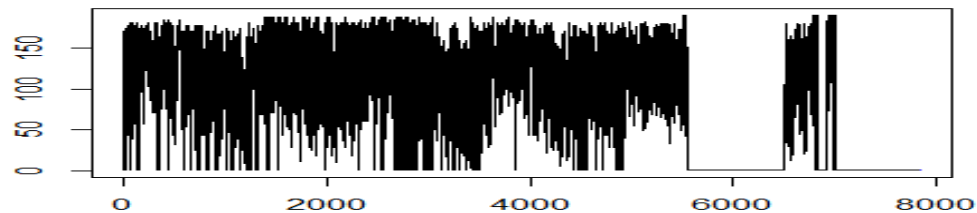

**Figure 4.** Forecast from TBATS Function

Since we are aware about seasonal decomposition, this may help us to explain why we do that as if the time series includes of a trend component, a seasonal component and an irregular component then decomposing is must require in this series .Here we saw no irregularity in the plot, so better not to perform seasonal decomposition of this series. The

**Decomposition of additive time series**

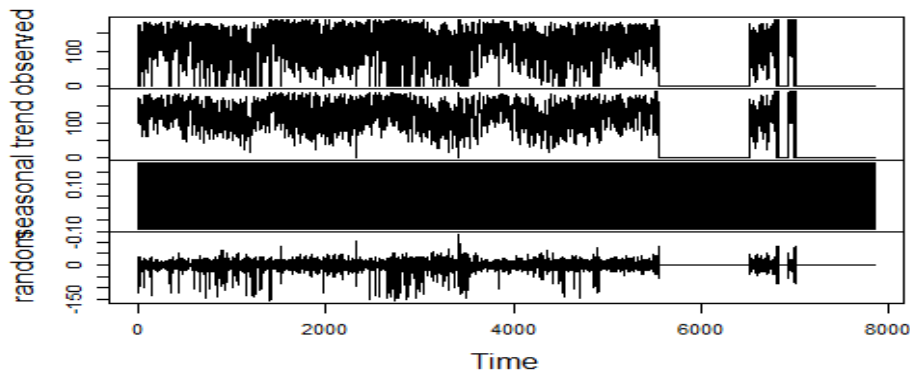
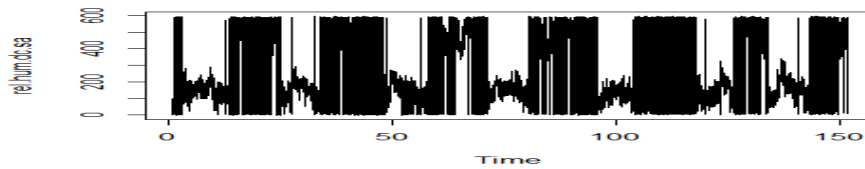

**Figure 5.** Decomposition of Additive Time Series



TBATS model was introduced by De Livera, Hyndman & Snyder (2011, JASA). By using decomposition procedures in time series to describe the trend and seasonal factors in a time series. The decompositions may also include long-run cycles, day of week effects and so on. Here, we'll only consider trend and seasonal decompositions. The main purposes for decomposition are to estimate seasonal effects that can be used to generate and current seasonally adjusted values.

The above plot shows the observed time series, the smoothed trend line, the seasonal pattern and the random part of the series. The seasonal pattern is a regularly repeating pattern. Hence After seasonally arranging the original time series we get:



**Figure 6.** Original Time Series after Seasonal Adjustment

For modeling by ACF and PACF, a proper model obtained for evaluating the average values of Relative Humidity of Delhi station was  $ARIMA(1, 1, 0)(1, 1, 0)_{12}$ .

**Table 4.** Coefficients of ARIMA Model  $(1, 1, 0)(1, 1, 0)_{12}(1, 1, 0)(1, 1, 0)_{12}$

	ar1	Sar1
Estimated	- 0.2895	- 0.5084
Std Error	0.0041	0.0037

$\sigma^2$  estimated as 320.4 , log likelihood= -236457.1, aic= 471924.2

### Hourly Temperature

In the first phase, the investigation of initial values of p, d and q is determined by ACF and PACF. The ACF of a giving lag is graphed as:

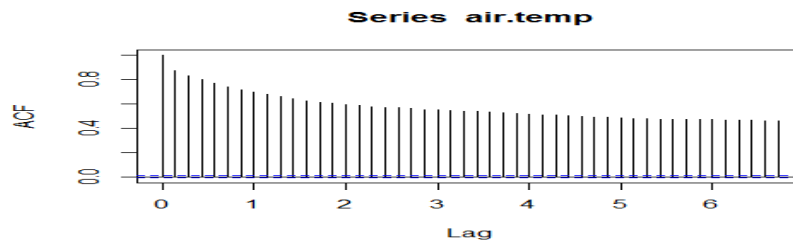

**Figure 7.** ACF Diagram for Residuals of Temperature

The PACF of a given lag is defined as:

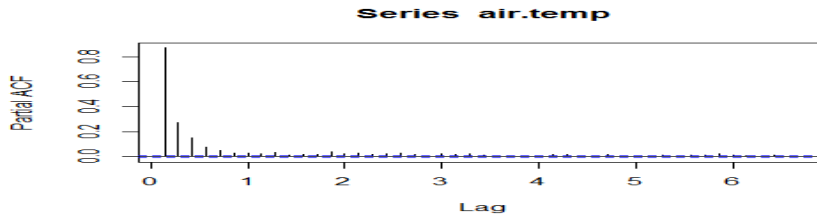

**Figure 8.** PACF Diagram for Residuals of Temperature

In Second phase, it is the ARIMA Model (4,1,1) is the best model for forecasting the parameters and it is the easiest model to implement and the model with least computation-time, in the forecasting procedure.

**Table 5.** Coefficients of ARIMA Model

ar1	ar2	ar3	ar4	ma1	
Estimated	0.5547	0.1498	0.0928	0.0504	-0.9899
Std Error	0.0044	0.0049	0.0049	0.0044	0.0012

$\sigma^2$  estimated as 9025: log likelihood=-328228.6

**Table 6.** Criteria's of ARIMA Model

AIC	AICc	BIC
656469.3	656469.3	656522.7

When the time series is long enough to take in more than a year, then it could be necessary to allow for annual seasonality as well as weekly seasonality is also identified. In that case, a multiple seasonal model such as TBATS is required.

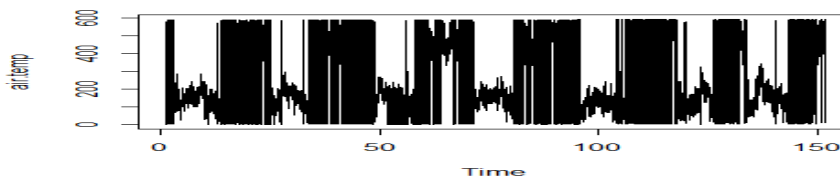

**Figure 9.** Forecasted from TBATS Function

In that case, a multiple seasonal model such as TBATS is required and it is given as:

Forecasts from TBATS(0.606, {1,2}, 0.964, {<7,1>, <365.25,

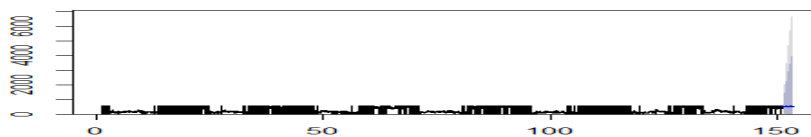

**Figure 10.** Forecasts from TBATS Function

For modeling by ACF and PACF, a proper model obtained for estimating the average values of Relative Humidity of Delhi station was ARIMA  $(1,1,0)(1,1,0)_{12}(1,1,0)(1,1,0)_{12}$

**Table 7.** Coefficients of ARIMA Model  $(1,1,0)(1,1,0)_{12}(1,1,0)(1,1,0)_{12}$

	ar1	Sar1
Estimated	- 0.3204	- 0.5175
Std Error	0.0040	0.0037

sigma<sup>2</sup> estimated as 14691, log likelihood = -341544.5, aic = 683095.1

**ETS MODEL**

Exponential Smoothing developed by Robert G. Brown’s. Models with additive and additive damped errors having the same parameters generated at the same point forecasts but having different forecast intervals.

ETS (A,**1,1**, N): Simple exponential smoothing with Additive Damped

A short-hand notation for this is  $e, \rho_t = Z, Z_t \sim (WN(0, \sigma^2))$ , The equations of the model can be written as:

$$y_t = l_{t-1} + Z_t$$

$$l_t = l_{t-1} + \alpha Z_t$$

**Hourly Relative Humidity**

Automatic forecasting technique is a method of forecasting using exponential smoothing function in forecast package in R [10]. The dynamically automatic forecasting algorithm is defined for ETS models.

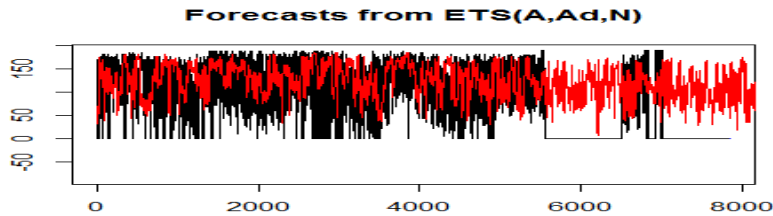

**Figure 11.** Forecasts of ETS (A,Ad,N)

**Hourly Temperature**

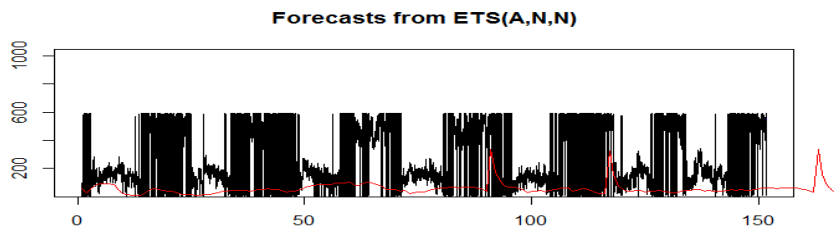

**Figure 12.** Hourly Temperature from ETS(A,Ad,N)

## DISCUSSION AND THE RESULT ANALYSIS

The possible models that correspond with our information, so much the ARIMA and the ETS, we understand a evaluation of all of them to choose which or which are better. In our study, all data, recorded in the Indian Meteorological Department, and is used for comparison study. We collected the eight years data from 2007 to 2014, and then after performing data pre-processing to clean data such as missing data and inconsistent data. The performance comparisons of ETS and ARIMA for Relative Humidity (3,1,1) and Temperature (4,1,1) model for MAE, MAPE, RMSE and ACF1 are shown below:

**Table 8.** Performance metric for Temperature

Performance criteria		ARIMA	ETS	ARIMA(1,1,0)(1,1,0) <sub>12</sub> (1,1,0)(1,1,0) <sub>12</sub>
1.	ME	8.981984	0.01630229	-0.0005882403
2.	RMSE	96.33831	96.68417	121.1906
3.	MAE	37.79438	32.45332	48.99444
4.	MPE	-131.9755	-149.5737	-139.3415
5.	MAPE	142.8036	159.1663	192.9006
6.	MASE	0.258155	0.2216728	1.728747
7.	ACF1	0.01794761	0.04147516	-0.05668485

## CONCLUSION

The model (3,1,1) exhibits the best performance for Relative Humidity and for temperature exhibits (4,1,1). The confirmation has been done using three common quality indexes, based in correlation procedures. In this research paper, the performances of ARIMA and ETS are then compared. ARIMA can more proficiently capture the vigorous behavior of the weather property compared to ETS. Therefore, the conclusion about the performance of ETS model is not complete and final. We need to investigate further in this direction. Our initial findings show that ARIMA is better than ETS.

## REFERENCES

- [1] Mahmudur Rahman, A.H.M. Saiful Islam , Sahah Yaser Maqnoon Nadvi , Rashedur M Rahman , “Comparative Study of ANFIS and ARIMA Model for weather forecasting in Dhaka” ,IEEE, 2013.
- [2] Garima Jain, Bhawna Mallick , “A Review on Weather Forecasting Techniques”, Vol. 5, Issue 12, 2016.
- [3] [www.mathworks.com](http://www.mathworks.com)
- [4] Robert H. Shumway, “ARIMA Models”, Springer Texts in Statistics, 2011.
- [5] Shabri, Ani Samsudin, Ruhaidah., “Forecasting using wavelet-based autoregressive integrated moving average models.Res”,Mathematical Problems in Engineering, Annual 2015 Issue.

- [6] Srikanth, P., D. Rajeswara Rao, and P. Vidyullatha, “Comparative Analysis of ANFIS, ARIMA and Polynomial Curve Fitting for Weather Forecasting”, *Indian Journal of Science and Technology*, 2016.
- [7] Hyndman, R. J., & Khandakar, “ Automatic time series for forecasting: the forecast Package for R (No. 6/07)”, Monash University of Department of Econometrics and Business Statistics, 2007.
- [8] Tektas M. Weather forecasting using ANFIS and ARIMA, “A case study for Istanbul. *Environmental Research, Engineering and Management*”, 2010; 1(51):5–10.
- [9] G.Vamsi Krishna (2014), “An Integrated Approach for Weather Forecasting based on Data Mining and Forecasting Analysis”, *Indian Journal of Computer Science and Engineering (IJCSE)* by Vol. 5 No.2 .
- [10] Robert H. Shumway, “ARIMA Models”, *Springer Texts in Statistics*, 2011.

# Diversity Management at Manchester United: A Case Study on the Alex Ferguson Era

SUSHANT PANDEY<sup>1</sup>

## Abstract

*Diversity in HRM is premised on the paradigm of building teams that are culturally inclusive and bring forth challenges and opportunities. Opportunities in diversity management in the domain of professional sport stem from the synergistic effects of different skill sets, different perceptions and different learning patterns. Challenges in team building based on diversity management stem from instituting a standard and homogenous work culture for enhances operational control, strategic control, defining KRAs on the job, profiling of job description and consequently in achieving targets defined by MBO. The case study on Manchester United spans from 1986 to 2013 covering the tenure of its most successful manager Sir Alex Ferguson, widely regarded as the greatest of all managers in professional sport. The case study uses the three coordinates of time, space and scale to analyse his diversity management strategy, performance management and team sustenance.*

**Keywords:** *Diversity Management, Team Building, Manchester United, HRM, Team Sustenance, Performance Management, Time, Space & scale*

## DIVERSITY MEANING

In the twentieth century, ecologists and agriculturalists developed an increasingly sophisticated understanding of the value of biological diversity, specifically the resilience and adaptability it brings to ecosystems. In the twenty-first century, the ecosystem model has been applied to human systems, particularly to understanding how organizations are structured and how they operate. Twenty-first century organizations are challenged by diversity in many arenas. Demographic changes in workforce composition and customer populations, combined with globalized markets and international competition are increasing the amount of diversity organizations must manage, both internally and externally. Many diversity specialists and business leaders argue that businesses and organizations interested in surviving and thriving in the twenty-first century need to take competitive advantage of a diverse workplace (Soutar, 2004; Yang, 2005). But to do so successfully, leaders and human resources (HR) managers must redefine management and leadership (Jones, 1989).

Just as mono-cropping destroys biological diversity, and, in extreme cases, such as the Irish potato famine—human as well as natural ecosystems (Keohane, n.d.), so does

---

<sup>1</sup> Director, Ishan Educational Institutions  
E-mail: drsushantpandey@gmail.com

mono-managing similarly destroy diversity within organizations. Leaders wanting to build strong, diverse organizations will not be successful if they rely on one approach or solution. Single-threaded diversity solutions, such as focusing only on recruitment or single-approach management techniques, such as requiring every employee to take diversity training, do not create lasting change (Kossek & Lobel, 1996; McMahon, 2006; Thomas, 1990). Bringing about the changes needed to build and sustain diversity requires commitment, strategy, communication, and concrete changes in organizational structure and processes. The trend in defining diversity “seems to favor a broad definition, one that goes beyond the visible differences” that, for many people, are too closely linked to affirmative action (How, 2007; Jones, 1999 ). One of the first researchers to use this inclusive definition, **R. Roosevelt Thomas, Jr.**, was pivotal in moving diversity thinking beyond narrow EEO/Affirmative Action categories. In his landmark work, *Beyond Race and Gender*, he argued that to manage diversity successfully, organizations must recognize that **race** and **gender** are only two of many diversity factors. Managers and leaders must expand their perspective on diversity to include a variety of other dimensions (Thomas, 1992, p. xv). Workplace diversity management, in his model, is also inclusive, defined as a “comprehensive managerial process for developing an environment that works for all employees.” (1992, p. 10). There is political value in this inclusiveness since it does not overtly threaten existing management structures which are still predominantly populated by white males. This general definition also enables all staff to feel included rather than excluded, permitting them “to connect and fortify relationships that enable employees to deal with more potentially volatile issues that may later arise” (How, 2007).

However, critics of this inclusive diversity definition charge that it can too easily devolve into a general ‘feel good’ approach that substitutes for real change (Cox, 2001; Welburn, 1999). In addition, critics argue that this definition fails to acknowledge the unequal treatment and limited opportunities experienced by those who differ from the dominant culture. Mor Barak expresses this criticism succinctly, stating that “It is important to note that there is a fundamental difference between attributes that make a person a unique human being and those that—based on group membership rather than individual characteristics—yield *negative or positive consequences*” (2005, p.122). Change cannot happen in the workplace, she argues, unless management understands that diversity “is about being susceptible to employment consequences as a result of one’s association within or outside certain groups” (2005, p. 122).

Framing workplace diversity initiatives affects the outcomes an organization achieves. For example, an organization may define diversity as regulatory compliance, as social justice, as the responsibility of only part of the organization, such as HR, as a strategic planning outcome, or as a community-focused activity (McMahon, 2006). Diversity outcomes derived from these definitions vary, but generally can be classified into five broad categories:

- Complying with federal and state requirements,
- Expecting and rewarding homogeneity,
- Identifying diversity as a broad goal without accompanying changes,

- Identifying discrete diversity goals and creating selective organizational changes to achieve them,
- Pursuing systemic and planned organizational change to take optimum strategic advantage of diversity.

This variety of approaches shows that organizations vary both in the degree to which they define diversity as valuable and in the amount of change they engage in to support workplace diversity (Hastings, 2006). To be successful, organizations must set implementation parameters by asking themselves three questions:

- “[Why] Do we want diversity?
- If so, what kind?
- If so, how much?” (Thomas, 1999, p. 55).

### **GERT HOFSTEDE’S FRAMEWORK**

Geert Hofstede is a Dutch researcher who is seen as a significant informant and researcher in intercultural studies. His book *Cultures and Organizations: Software of the Mind* is considered an important cornerstone in the research field. A great number of business studies have taken his theory as a framework and many other cross-cultural training programs are based on his data.

#### **THE FIRST COLLECTIVE VALUE DIMENSION: POWER DISTANCE**

At the universal level, *Power* is a fundamental concern because human groups everywhere are organized into a hierarchy. Decision makers are present in groups of any size and ethnicity (e.g. the head of a family, the chief of a tribe, or the rulers of a city state, etc.). The value attached to power is called *Power Distance*, defined as the extent to which the less powerful members of the society accept and expect that power is distributed unequally.

#### **THE SECOND COLLECTIVE VALUE DIMENSION: GROUP ATTACHMENT**

At the universal level, we are born with a very perceptive mind to be ready in joining the first cultural group we see after birth. Step by step, children become integrated into different in-groups such as family, school, workplace, etc., and learn to think of themselves as part of the “we” group, distinct from other people in society who belong to the “they” group (out-group). The tendency for humans to form different groups is because cultural diversity is a critical strategy to protect collective knowledge and heritage. It helps us recognize who belongs to our in-group, and thus defines who we can trust, who we can share our knowledge with, and who we can live and die for. *Group* is therefore a fundamental concern, universally significant in all human societies. With this concern, the entire human race also shares the same value that exhibits the relationship between each individual and his/her group. Hofstede does not give a generic name to this universal value like what he did with the previous value of Power Distance, so we will term it in this book *Group Attachment*.



### **THE THIRD DIMENSION: GENDER ASSOCIATION**

In our modern days, the role of men and women are largely overlapped. Men are increasingly working in occupations which traditionally are more popular with women and vice versa. Thanks to culture, we do not entirely rely on genes but develop accumulated knowledge and technology to reach the most optimal labour specification. Genetic features play less and less important roles in deciding what a person can do. However, our psychology is still very clearly influenced by the dichotomy of men-women, to the extent that despite the more convergent reality, the cultural traits we tend to assign to each gender are more divergent. Competition and aggression for example are usually attributed to the masculine side, and caring or loving are to the feminine side.

### **THE FOURTH DIMENSION: UNCERTAINTY AVOIDANCE**

Trying to predict and avoid harm is universal and part of basic human instinct. Fear is the result of both strongly innate feeling and social learning. In general, we have several inborn fears, for example the fear of falling and the fear caused by loud noises. These fears are genetically coded in our body and it is a healthy emotion since it helps keep us from harm. Most other fears are learned from the culture of our life, what is good and what is bad, what is safe and what is dangerous. Our fear may have an object (fear of the dark) or no specific object. The latter is called *Uncertainty*.

### **THE FIFTH VALUE DIMENSION: TIME ORIENTATION**

Human societies have always been organized within space and *Time*. The former is related to the relationship between human and nature, a value dimension we will explore in the next chapter within the framework of Trompenaars. The latter focuses on how we perceive and vision our life activities across the time spectrum. *Time Orientation* is a universal value that relates to how we see the influence of the past, presence and future in our life: How far we plan ahead; how quick we expect our result and rewards; how important is saving and spending, etc.

At the collective level, time spectrum exerts different degree of influence in different societies, creating two orientations on this value dimension: short- and long-term Time Orientation. In a nutshell, *a focus on the past and the present* would lead more towards short-term Time Orientation, and *a focus on the future* will lead more towards long-term Time Orientation. This value dimension is inspired by Confucianism, a philosophy of life originated in ancient China. It focuses on virtues with incredibly strong emphasis on acquiring skills and education, working hard, not spending more than necessary, being patient and persevering, and being well prepared for the future. These fundamental virtues play as cornerstones of life in all the societies under the influence of Confucianism: China, Vietnam, Korea, Japan, Singapore and Taiwan. Unsurprisingly, these are also the countries with a tendency of leaning towards long-term Time Orientation. In the index table, the higher the score, the more important future exerts a significant influence in people's life.

### AMARTYA SEN'S MISSING WOMEN MYSTERY

The term was first coined in the late 1980s by Nobel Prize laureate Amartya Sen. The economist observed that the demographic deficit of women affecting mainly Asia and North Africa went against biological trends: indeed, when they receive the same care, infant boys are normally more vulnerable to mortality than girls, often resulting in women outnumbering men in the adult population. Therefore, Sen argued, the primary cause for unequal sex ratios is discriminatory treatment rooted in the cultural preference for boys (Sen, 1990). The 2014 Social Institutions and Gender Index (SIGI) defines missing women as the “shortfall in the number of women in sex ratios for ages 0-4, 5-9, 10-14, 15-64, 65+ relative to the expected number if there were no sex-selective abortions, no female infanticide or similar levels of health care and nutrition” (OECD Development Centre, 2014). Back in 1990, Sen estimated there were as many as 100 million missing women. A quarter century later, the 2014 Social Institutions and Gender Index (SIGI) findings are close to Sen’s: over 90 million women are missing around the world. 80% of these missing women are from India and the People’s Republic of China (OECD Development Centre, 2014). Other estimates by UNFPA (2012) based on 2010 demographic surveys found that the number of missing women was even higher at 117 million. In India, the 2011 Census found a worrying trend in child sex ratios with only 914 females for 1,000 males, a drop from 927 in 2001. The number of selective abortions of girls rose from 3.1 to 6 million in the 2000s. Missing women are a matter of concern in the broader South Asian region (SIGI website).

In a survey conducted in rural China, 36% of married women acknowledged undergoing sex-selective abortions. As of 2007, China had approximately 42.6 million missing women (SIGI website). While remaining extremely high, numbers of missing women seem to have fallen in China and more generally in the East Asia and Pacific region since 2012 (OECD Development Centre, 2014).

Research suggests that unequal sex ratios are driven by the interplay of several factors:

- *Economic factors*: The primary motivation for son bias can be financial. Many societies indeed consider boys as a lifelong economic resource, while girls are seen as a liability (OECD, 2012). In China, sons are indeed expected to provide for their parents upon their retirement, whereas girls, once married, will contribute to their in-laws families instead. Social institutions such as dowry also fuel sex selection – an advert for an abortion clinic in India called parents to “Pay 50 rupees now to save 50,00 rupees later” (Jones and al, 2010).
- *Socio-cultural factors*: Sons can be associated with higher social prestige. For instance, for Vietnamese fathers, having a boy is associated with masculinity and with being blessed, according to a survey (Jones and al. 2010). Women themselves can be under tremendous social pressure to give birth to a son, facing threats of violence, rejection or death if they fail to do so (WHO, 2011).
- *Family planning policies*: Increasing access to sex selective abortion, combined with restrictive family planning such as such as China’s one child policy until 2015, are

other factors that drive the missing women phenomenon (Klasen and Wink, 2003; OECD 2012).

### **BUSINESS IMPLICATIONS OF CULTURAL DIFFERENCES**

- If organizations and the people who comprise them worked in foxholes, this approach to surviving—dropping homogeneity as a criterion for full participation—would be compelling. In life-or-death situations, many people will suspend beliefs, change behaviours, and embrace new solutions. However, the current business and organizational climate is not sufficiently dire that most employees would quickly and completely commit to the broad and deep changes required to sustain genuinely diverse workplaces.
- Human Resources directors face a serious challenge in developing organizational diversity. The changes needed are particularly difficult (Porter, 1995; Schein, 1996; Zane, 2002). Meeting this challenge takes top management commitment, the skilled training and breadth of organizational knowledge HR possesses, and a shared understanding that managing diversity is not a problem to be solved but an ongoing and lengthy process. All three of these pieces are needed to sustain people's willingness to work together when they do not share values, experiences, culture, and ways of interpreting meaning and solving problems (Zane, 2002).
- Researchers have documented two reasons why implementing diversity in the workplace is difficult (Bassett-Jones, 2005; Cox, 2001; Galagan, 1993; Moore, 1999; Thomas, 1992). First, human beings prefer working in homogeneous groups. Second, human beings, and the organizations they are a part of, generally avoid and resist change. Successful diversity management requires HR managers to possess skills in leadership, organizational development, change management, psychology, communication, measurement, and assessment. Such cross-cutting skills might seem broadly useful to the success of any business initiative. However, there is a key difference with diversity management. For organizations to profit from diversity, the people in those organizations must change how they interact. Diversity's focus on changing human processes requires and defines HR's role in diversity management.

### **TEAM DIVERSITY AT MANCHESTER UNITED**

Manchester United's team composition has been analysed objectively for nationalities. Despite the fact that nationalities may not be the best proxy for cultural homogeneity, yet it does suffice to objectively assess the team composition of Manchester United from the perspective of a multinational corporation that has free access to scout for top football talent from across the globe. Of the players that have 25-99 performances over the 30 year period from 1986-2017 the following insights can be drawn with regard to their nationalities and consequently about the nations that have offered diverse headcounts of football talent to Manchester United during much of the era of Sir Alex Ferguson:

**Table1.** Team Diversity at Manchester United as Measured by Nationalities of Players with 25-99 Match Appearances

<i>Nation</i>	<i>Players with 25-99 match Performances Contributed to Manchester United during the tenure of Sir Alex Ferguson</i>
Ireland	2
England	17
Scotland	3
Australia	1
Czech Republic	1
Netherlands	4
France	6
Argentina	5
Northern Ireland	2
Uruguay	1
Brazil	2
Cameroon	1
United States	1
Poland	1
Italy	2
Denmark	2
Japan	1
Belgium	1
Colombia	1
Germany	1

**TEAM DIVERSITY OF MANCHESTER UNITED IN RESPECTIVE SEASONS****Table2.** Team Diversity at Manchester United in Seasons from 1992-2017

<i>Season</i>	<i>Nationalities</i>	<i>Composition</i>
1992		England-20, Denmark-1, Ireland-2, Northern Ireland-2, Scotland-2, Russia-1, Wales-3, France-1
1993		England-21, France-1, Denmark-1, Wales-5, Northern Ireland-2, Ireland-2, Scotland-2, Russia-1
1994		England-20, Scotland-2, Denmark-1, France-1, Wales-3, Ireland-2, Northern Ireland-3, Russia-1
1995		England-21, Russia-1, France-1, Denmark-1, Scotland-1, Wales-2, Northern Ireland-2, Ireland-2
1996		England-24, Scotland-2, Norway-4, Netherlands-2, Gibraltar-1, Denmark-1, Czech republic-1, Wales-1, Ireland-3
1997		England-24, Scotland-2, Norway-4, Netherlands-2, Gibraltar-1, Denmark-1, Czech republic-1, Wales-1, Ireland-3

<i>Season</i>	<i>Nationalities</i>	<i>Composition</i>
1998		Trinidad & Tobago-1, Netherlands-2, Scotland-3, Serbia-1, Gibraltar-1, Sweden-1, Norway-3, England-21, Ireland-3, Northern Ireland-1, Gibraltar-1, Wales-1,
1999		England-22, Norway-4, Scotland-2, Italy-1, United States-1, Australia-1, Netherlands-2, France-1, Trinidad & Tobago-1, Northern Ireland-1, Wales-1, Gibraltar-1, Ireland-3, South Africa-1, Serbia-1
2000		England-23, Norway-2, Northern Ireland-1, Scotland-4, Trinidad & Tobago-1, Wales-2, South Africa-1, Australia-1, United States-1, Italy-1, Sweden-1, Serbia-1
2001		England-21, Wales-2, United States-1, Sweden-1, Serbia-1, Uruguay-1, France-3, Norway-2, Northern Ireland-1, Ireland-3, Argentina-1, Wales-2, Netherlands-2, South Africa-1, Scotland-2
2002		England-21, Wales-2, United States-1, Sweden-1, Serbia-1, Uruguay-1, France-3, Norway-2, Northern Ireland-1, Ireland-3, Argentina-1, Wales-2, Netherlands-2, South Africa-1, Scotland-2
2003		Portugal-1, Brazil-1, Cameroon-1, China-1, Spain-1, England-21, United States-1, Sweden-3, South Africa-1, Serbia-1, France-3, Wales-3, Ireland-3, Northern Ireland-1, Netherlands-3
2004		Belgium-1, Uruguay-1, Portugal-1, China-1, United States-3, Brazil-1, Cameroon-1, Italy-1, Spain-1, South Africa-1, Argentina-1, England-21, Ireland-3, Northern Ireland-2, Scotland-2, Sweden-3, Netherlands-1
2005		China-1, Italy-1, Belgium-1, Germany-1, South Korea-1, Portugal-1, Spain-1, Ireland-3, Sweden-3, Northern Ireland-2, United States-2, Norway-2, France-2, Netherlands-2, South Africa-1, England-21
2006		Angola-1, Portugal-2, England-21, South Africa-1, South Korea-1, Argentina-1, Spain-1, Netherlands-3, United States-2, Ireland-3, Northern Ireland-1, Wales-3, Sweden-2, Norway-2, France-2,
2007		Mexico-1, Poland-1, Ecuador-1, Portugal-2, Brazil-2, Serbia-1, Belgium-1, Senegal-1, South Korea-1, Bulgaria-1, England-19, Ireland-3, Northern Ireland-3, France-3, Italy-1, Norway-2, Netherlands-3

<i>Season</i>	<i>Nationalities</i>	<i>Composition</i>
2008		Mexico-1, Poland-1, Ecuador-1, Portugal-2, Brazil-2, Serbia-1, Belgium-1, Senegal-1, South Korea-1, Bulgaria-1, England-19, Ireland-3, Northern Ireland-3, France-3, Italy-1, Norway-2, Netherlands-3
2009		Mexico-1, Poland-1, Ecuador-1, Portugal-2, Brazil-2, Serbia-1, Belgium-1, Senegal-1, South Korea-1, Bulgaria-1, England-19, Ireland-3, Northern Ireland-3, France-3, Italy-1, Norway-2, Netherlands-3
2010		Mexico-1, Poland-1, Ecuador-1, Portugal-2, Brazil-2, Serbia-1, Belgium-1, Senegal-1, South Korea-1, Bulgaria-1, England-19, Ireland-3, Northern Ireland-3, France-3, Italy-1, Norway-2, Netherlands-3
2011		Brazil-4, Spain-2, Bulgaria-1, Albania-1, England-21, Ivory Coast-1, Japan-1, Denmark-1, Chile-1, Italy-1, Belgium-2, Mexico-1, Ecuador-1, Spain-1, Portugal-2, Norway-2, France-2, Netherlands-1
2012		Spain-5, Ecuador-1, Chile-2, Colombia-2, Mexico-2, Ivory Coast-1, Belgium-1, England-29, Denmark-2, Brazil-3
2013		Spain-3, Ecuador-1, Chile-2, Colombia-2, Mexico-3, Ivory Coast-1, Belgium-2, England-29, Denmark-3, Brazil-3
2014		Spain-5, Ecuador-1, Chile-2, Colombia-2, Mexico-2, Ivory Coast-1, Belgium-1, England-29, Denmark-2, Brazil-3
2015		Argentina-2, Germany-1, Sweden-1, Armenia-1, Ivory Coast-1, Spain-3, Portugal-2, England-19, Belgium-2, France-2, Italy-1, Ecuador-1, Netherlands-2,
2016		Argentina-2, Germany-1, Sweden-1, Armenia-1, Ivory Coast-1, Spain-3, Portugal-2, England-19, Belgium-2, France-2, Italy-1, Ecuador-1, Netherlands-2,
2017		Argentina-2, Germany-1, Sweden-1, Armenia-1, Ivory Coast-1, Spain-3, Portugal-2, England-19, Belgium-2, France-2, Italy-1, Ecuador-1, Netherlands-2,

### **DIVERSITY AND TEAM PERFORMANCE IN EPL CLUB FOOTBALL**

Manchester United the iconic football club and the most celebrated and decorated franchise in the history of the English Premier League (EPL) under the leadership of its manager

Sir Alex Ferguson had a golden run from 1986 to 2013. This history is worthy of analysis from the perspective of team performance in the probably the world's most consistently competitive and tough club football climate.

- It must be noted that 5 of the most consistent EPL franchises including Manchester United, Chelsea, Arsenal, Liverpool and Everton have a history of a high manager turnover ratio. This is best gauged from the fact that these top 5 EPL club teams have axed a manager or senior coach on losing a maximum of 7 matches during the EPL season and at times on losing 3 consecutive matches.
- Players with record signing amounts of the season have also not been spared from the axe during lean patches of their game. Star players have been axed, leased to other teams or dropped from the playing eleven to the dugouts for warm up for not being able to score a goal or an assist in 5.26 matches on a trot, as measured by arithmetic mean for all players with 25-99 match performances that played in the last 30 years (1986-2017)
- The career span of all managers in the EPL that have been on duty for 25-99 matches, over the last 30 years (1986-2017) as measured by the arithmetic mean is 21 months. This drops further to 11 months for managers on duty for 25-99 matches, over the last 30 years (1986-2017) that have lost more than 7 matches in a single EPL season.
- The Football Association does not impose any restriction on the number of foreign players in the official playing squad announced on match day in EPL.
- The Football Association does require at least 8 “home-grown” players in the top 25 member squad each of the age of 21 years or above, announced by an EPL franchise for a league season.
- Sir Alex Ferguson's tenure at Manchester United as the club's manager stretched from 1986-2013, beating the regime of Sir Mat Busby (1945-1969).
- Sir Alex Ferguson during his stint as the manager of Manchester United accomplished and achieved the following:

38 trophies



## **DIVERSITY AND PERFORMANCE MANAGEMENT UNDER SIR ALEX FERGUSON AT MANCHESTER UNITED: FINDINGS**

United are a club who, since the construction of Old Trafford in 1910, have enjoyed significant financial advantages over many of their rivals. As the most successful team in English history in terms of league titles won, they have made the most of that. And yet only three managers have ever led them to the league title.

This is not a problem many football cultures face. There aren't many places where a manager is invested with such power, where he has such control over the philosophy of the club.

- **Be Consistent in Imposing Discipline:** Being consistent, says Ferguson, is the essence of being a leader. Discipline is an important aspect of management, and employees need to know who you are and trust that you are right when you impose rules. But don't be too quick to resort to severe sanctions. "Inexperienced, or insecure, leaders are often tempted to make any infraction a capital offense. That is all well and good — except, once you have hung the person, you are plumb out of options," he says.
- **Embrace Your Entire Team:** Long before he became a coach, Ferguson was a player, and he still remembers the coach who didn't say good morning but would just walk by. "You must recognize that people are working for you. Knowing their names, saying good morning in the morning is critical," he says.

And every time you win a cup or a trophy, Ferguson says, you should bring every member of your staff into that canteen — "the laundry girls, the canteen staff, the groundsmen" — and pour the champagne for everyone because it's their trophy as much as the players'.

- **Firing Is Hard — Do It Right:** Firing people is never easy, says Ferguson, but once a manager realizes it needs to be done, "nothing beats honesty. I gradually learned that there was no point beating about the bush by taking somebody out for dinner or sending his wife a box of chocolates or flowers to try to soften the news. The gimmicks don't change the message."
- **Lean Forward:** Body language is important: Someone who sits up properly and is leaning forward a little is showing that they are eager to start, says Ferguson. Asking questions at a job interview is crucial. "I often get a measure of someone by listening to the questions they pose. It shows how they think; offers a sense of their level of experience and degree of maturity," he says.
- **Build a Grassroots Level Talent Development System:** It was 1986 when Sir Alex Ferguson first joined Manchester United. One of the first things he did was to initiate two centres of excellence dedicated to the youth. His definition of youth was as young as nine years of age. To streamline his efforts to build the grassroots level program he recruited many scouts whose job was to spot and identify top football talent in schools, localities and clubs and report their findings to Ferguson, brief him and initiate proceedings for trials at the centres of excellence. This led to some major talent developments. David Beckham, Ryan Giggs, Paul Scholes and Garry Neville were among some of his early finds who later became top performers for Manchester United and England. At that time many had questioned the rationale behind such steps but the results paid put the questions with time. There are two lessons. Create the ambience of being back in school. Enable top young talent to learn from a very young age and pool them



together so that they learn about each other's game and grow up being part of a cohesive unit before joining the senior team.

- **Rebuild the Team to Maintain the Competitive Advantage:** Even at the peak of the team's success Sir Alex Ferguson continued to streamline his search for top talent. All the players available with the club were categorized into three demographic levels: above 30, 23 years to 30 years and the young ones who fell into the age bracket below 23 years of age. Players falling under the age group of above 30 years of age were assigned the task of leading the team, setting examples in the training session, working with the manager on strategy and tactics for matches and share their experience with the young players below 23 years of age and groom them on and off the pitch. The players in the age group of 23 years to 30 years were assigned tasks of performance on the pitch, maintaining discipline in the club in practice sessions, gym session and relief and rehabilitation sessions. The young players were put to test in the practice and occasionally used as substitutes for the senior players in matches. Ferguson's assessment was that a team's cycle lasted for 4 years and hence it was imperative to maintain a portfolio of talent on these lines and match roles and responsibilities to the stage of the team life cycle the concerned player was going through. It was in a sense very similar to the inventory based approach to human resource retention.
- **Total Quality Management On and Off the Pitch:** Ferguson was the ultimate total quality management freak in football. He never allowed a single bad training session during his entire tenure at the club. More than sharpening the technical skills of the players at Manchester United, he was more concerned about the players not giving in. Attitude formation was given due importance and discipline was chosen over motivation. Work ethic and sustainable high energy levels were stresses upon in training with the single minded logic that what is produced in training gets manifested on the field. Ferguson recruited what he called "bad losers". These were players who were great on dedication, work ethic and talent and yet may have lost some golden opportunities at the junior level. Each of his training sessions was based on development of intensity, speed, focus and a high level of performance. There was not a single day when Ferguson allowed any player, not even the great players like Beckham, Ronaldo, Rooney, Scholes or Nistelrooy to get away with a half hearted or less than 100% commitment at training. This showed in the games that Manchester United played. Such was the impact that these great players would practice for hours at a stretch so much so that Ferguson would have to actually chase them in from practice to prevent exhaustion.
- **Being in Charge and in Control:** Ferguson kept things simple and in control. Right from the first day when he took charge at Manchester United he was high on self belief that if he had to transform Manchester United into one of the best in the business he had to do things his way not the players' way. For that to happen he had to be in control of the tactics, strategy, discipline, training sessions, off days and recruitment. His personality was higher and bigger than that of the players. That allowed him to earn the respect of the players and everybody else at the club. Not for a single day was indiscipline tolerated. For example when Nistelrooy disgruntled in public he was promptly transferred to Real Madrid. When Roy Keane publicly criticized his team mates his contract was terminated. These actions sent out a message that it was the manager of Manchester United who was in command and not anybody else.

- **Timing the Communication:** Nobody likes to be criticized and especially not the superstars of football. There has to be a courage, honesty, politeness and firmness in the way a manager says no to players. The manager needs to have these elements in him to be able to match the message to the moment. This is especially needed in situations when players had to be rested, substituted or axed from the team. Ferguson combined the roles of a doctor, teacher, parent and critic as a manager and his boys knew that he meant business. There was no messing around with him once a message had been delivered. A no nonsense approach improved the longevity of the team along with that of Ferguson and the players. No big player created at Manchester United ever wanted to leave the club because they knew that the opportunities for self development at the club were immense. This was in part a result of the communication that Ferguson committed himself to.
- **Play to Win:** Managers talk of being flexible and situational. There are three coordinates for any situation in business and sport: time, space and scale. To play to win teams have to learn to prepare to win. A great part of that preparation need to be streamlined across these three coordinates of time, space and scale. That meant that Ferguson had to build and develop tactics, strategy, intensity and above all the technical and analytical skills in players separately for these three coordinates of time, space and scale. Manchester United practiced separately for a situation when they were going down 0-1 with 45 minutes, 30 minutes, 15 minutes, 10 minutes and 5 minutes of play left. The efforts reflected in the results on the field with Manchester United winning many close matches during Ferguson's tenure. Also the team practised very differently for away matches and home matches. The third check point in training sessions was that of scale. Ferguson prepared his players to repeat performances time and again and that was done keeping in mind the long schedules of the EPL and the UEFA.

## CONCLUSION

- Two core resources for workplace diversity best practices are Aronson's (2002) article on "Managing the diversity revolution: Best practices for 21<sup>st</sup> century business" and the U.S. G.A.O.'s (2005) report on "Diversity management: Expert-identified leading practices and agency examples". Aronson gives an excellent overview of workplace diversity, outlining how to institute a diversity initiative, summarizing the principles on which it should be based, and providing a substantial number of best practices examples implemented by various companies. The GAO's review included a comprehensive literature review, a detailed analysis of the writings of five diversity experts, and interviews with an additional 14 experts. From this process, they identified nine best practices. The two works complement each other. Aronson's business perspective and wealth of best practices detail is balanced by the GAO's non-profit agency examples and its high-level focus on diversity principles.

The GAO's nine leading best practices are:

1. Top **leadership commitment**—a vision of diversity demonstrated and communicated throughout an organization by top-level management.
2. **Diversity as part of an organization's strategic plan**—a diversity strategy and plan that are developed and aligned with the organization's strategic plan.

3. **Diversity linked to performance**—the understanding that a more diverse and inclusive work environment can yield greater productivity and help improve individual and organizational performance.
  4. **Measurement**—a set of quantitative and qualitative measures of the impact of various aspects of an overall diversity program.
  5. **Accountability**—the means to ensure that leaders are responsible for diversity by linking their performance assessment and compensation to the progress of diversity initiatives.
  6. **Succession planning**—an ongoing, strategic process for identifying and developing a diverse pool of talent for an organization’s potential future leaders.
  7. **Recruitment**—the process of attracting a supply of qualified, diverse applicants for employment.
  8. **Diversity training**—organizational efforts to inform and educate management and staff about diversity’s benefits to the organization (2005, p. 4).
- Aronson’s analysis presents top-level best practices but also drills down into more detailed and specific advice and examples of tactics, practices, and policies. He begins with the same requirement as the GAO’s analysis—commitment from the top—with a similar focus on communication and demonstration which he calls concrete actions.

Defining diversity as inclusiveness, he asserts that the second best practice is ‘bringing people on board’. While this practice did not make the GAO’s list, from many diversity experts’ writings (Digh, 1998a; Mor Borak, 2005; Thomas, 1992), employee involvement is critical to building workplace diversity success. His third practice, which is implied by several of the practices the GAO identified, is assessing where an organization currently stands, that is, a diversity audit. His suggestions for how to conduct this audit match the advice given in a number of other textbooks and articles on diversity (Coats, Goodwin, & Bangs, 2000; Love, 2001; Winston & Li, 2000). The fourth, and the most detailed, best practice mirrors the GAO’s second practice. An organization must develop a strategic plan to promote diversity and Aronson’s includes six critical elements:

- A compelling analysis of the business case identifying diversity’s advantage(s) for the organization.
- Recommendations for involving all employees in the diversity effort.
- Institutionalization of the diversity initiative through an office or individual responsible for the strategic plan at the executive level.
- Clearly defined goals tied to the gaps found through the diversity audit and the business goals.
- Diversity metrics to track progress toward those goals.
- Accountability metrics which hold managers responsible for meeting diversity goals (2002, p. 16-18).

## REFERENCES

- [1] Carr-Ruffino, N. (1996). *Managing diversity: People skills for a multicultural workplace*. Stamford, CT: Thompson Executive Press.
- [2] Cox, T., Jr. (2001). *Creating the multicultural organization: A strategy for capturing the power of diversity*. San Francisco: Jossey-Bass.
- [3] Kossek, E.E., & Lobel, S.A. (Eds.). (1996). *Managing diversity: Human resources strategies for transforming the workplace*. Cambridge, MA: Blackwell.
- [4] Dobbs, M.F. (1996). Managing diversity: Lessons from the private sector. *Public Personnel Management*, 25, 351-368.
- [5] Mor Borak, M. (2005). *Managing diversity: Toward a globally inclusive workplace*.
- [6] Thomas, R.R., Jr. (1992). *Beyond race and gender: Unleashing the power of your total work force by managing diversity*. New York: AMACOM.
- [7] Maier, C. (2005). A conceptual framework for leading diversity. *International Journal of Human Resources Development and Management*, 5, 412-424.
- [8] Makower, J. (1995). Managing diversity in the workplace. *Business and Society Review*, 92, 48-54.
- [9] Soutar, S. (2004). Beyond the rainbow. *Association Management*, 56, 26-33.
- [10] Lynch, F.R. (1992). Managing diversity: Multiculturalism enters the workplace. *Academic Questions*, 6, 81-87.
- [11] Kwak, M. (2003). The paradoxical effects of diversity. *MIT Sloan Management Review*, 44, 7-8.
- [12] Dass, P., & Parker, B. (1999). Strategies for managing human resource diversity: From resistance to learning. *Academy of Management Executive*, 13, 68-80.
- [13] Friday, E., & Friday, S.S. (2003). Managing diversity using a strategic planned change approach. *Journal of Management Development*, 22, 863-880.
- [14] Chow, I.H.S., & Crawford, R.B. (2004). Gender, ethnic diversity, and career advancement in the workplace: The social identity perspective. *SAM Advanced Management Journal*, 69, 22-32

# Next Generation Entrepreneurship Through Technological Innovation

S.S. PIPARA<sup>1</sup> AND DEEKSHA MATHUR<sup>1</sup>

## ABSTRACT

*The current century has changed entire norms of doing business since e-governance in every sphere of life has made an impact at such a rapid pace that demands for responsive behavior in dealing with all stake holders simultaneously. It is truly said that survival is for the fittest only in this competitive business era. Innovation in product Quality/Service on continuous basis is the key to capture customer's voice besides cost and delivery parameters to the entire satisfaction of customers. This will also facilitate product branding which will take the business to next level.*

*The ever changing customer choice calls for product R & D besides management of other resources for improved productivity and profitability. The entrepreneur has to adopt lean management concepts under world class manufacturing set up. However, the manager needs to look into minute details to ensure consistency in product quality and keep an eye on fast changing market scenario.*

*The entrepreneur has to take calculated risk and must have a vision along with a well defined road map for taking the team together without any iota of doubt. To arrive at this, different brain storming sessions are called for in stages. This approach will ensure participative work culture and decision making at various levels in the organization which is paramount to facilitate increase in market share of their product and launching of new product for different segment of customers across the globe. Finally, every employ in the organization have to be part of digital economy.*

**Keywords:** Stakeholders, Competitive Business Era, Lean Management, World Class Manufacturing, Digital Economy, e-Governance, Vision and Road Map, R & D and Innovation

## INTRODUCTION

The Entrepreneurship concept has continuously undergone change in last couple of centuries owing to market forces and entry of big players taking large share of business. With the technological advancement, there is fierce competition since adoption of world class manufacturing facilities in place and cost reduction through practice of lean management and implementing productivity measures to achieve higher level of operational efficiency in every gamut of procurement to after sales service.

---

<sup>1</sup> Management Faculty, Avviare Educational Hub, C-56, A/20 Sector -62, Noida  
E-mail: sardarpipara@gmail.com, mathur\_deeksha@yahoo.com.hk

Productivity is primarily:

- An Attitude of mind
- An Attitude of welcoming a change for the better
- An Attitude of making the optimum use of available resources towards the achievement of a specified goal.

In short: Productivity stands for elimination of waste in all forms.

## **EMPOWERING A NEXT GENERATION OF YOUNG ENTREPRENEURS**

Youth entrepreneurship is high on the political agenda as a means to boost competitiveness and employment. Young entrepreneurs have the potential to build a new economic dynamic generating growth and jobs. The EU's 2020 growth strategy gives particular attention to entrepreneurship promotion and includes an entrepreneurship action plan that focuses attention on creating a more enabling environment to support youth entrepreneurship.

With many of ETF's 30 partner countries signing up to the Small Business Act for Europe the opportunity to build the next generation of young entrepreneurs has never been better. This policy briefly outlines a number of key considerations for governments, private sector and civic interest groups to move forward with more strategic promotion of youth entrepreneurship in ETF partner countries.

## **WHY FOCUS ON YOUTH ENTREPRENEURSHIP?**

Growing youth unemployment threatens economic and political stability. Countries with high youth demographic profiles are even more at risk. Further, negative growth means decreasing work opportunities and the need for alternative means of job creation. Youth entrepreneurship can be part of the solution. Education and training are critical to develop the entrepreneurial mind set and specific skills for business start-up and development. But education and training cannot be disconnected from the wider entrepreneurship support system. A coordinated policy response is necessary to ensure the energy and drive of young people is best harnessed to meet the needs of a 21st century economy.

Entrepreneurship education and training cannot be disconnected from the wider entrepreneurship support system.

## **ENTREPRENEURIAL CULTURE**

Cultural perceptions and acceptance of both entrepreneurship risk and entrepreneurship failure are considerable obstacles to building an entrepreneurial society. Policymakers have a role to play here. Given that policy frames public opinion, policymakers should consider how the profiling of successful young entrepreneurs as role models, and use of social media, could contribute to a more favourable entrepreneurship culture. Recognising failure as a learning opportunity must be part of the policy message. In addition, a rethink of the teaching and learning processes in school is necessary to equip young people

with the skills to manage failure and success which are particular challenges for today's entrepreneur.

## **ENTREPRENEURIAL LEARNING**

Evidence shows that the rate of students who start up their own company increases three-fold after participation in an entrepreneurship programme at school. The EU's 2020 entrepreneurship action plan builds on this data by promoting an 'entrepreneurship experience' as part of compulsory schooling for all young people. Policymakers in ETF partner countries should consider integrating the '**entrepreneurship experience**' into school curriculum. Entrepreneurship in ETF partner countries is better developed in vocational education and training with a specific focus on building business skills. However, more attention needs to be given to entrepreneurship as a 'key competence' to build the entrepreneurial mindset of the next generation. The entrepreneurial mindset comprises a set of cognitive and behavioural traits e.g. opportunity seeking, risk management and creative problem solving. The crux of the issue is that in developing the entrepreneurial mindset of young people, we not only prepare them for business start-ups. Those who do not take the start-up route make for more entrepreneurial employees boosting quality and productivity in the workplace. Further, a policy framework to support lifelong entrepreneurial learning is needed to create change throughout the system. Addressing entrepreneurship from primary to tertiary level creates the potential for a 'domino effect' throughout the learning system. Engagement of the non-formal and private sector in entrepreneurship promotion in schools, colleges and universities can enhance the curriculum and learning process. Teacher training (both pre-service and in-service) will be critical to the wider entrepreneurial learning drive. In brief, teachers and schools need to be an integral part of a nation's entrepreneurship agenda.

## **ENTREPRENEURSHIP IN POST-SECONDARY EDUCATION**

Entrepreneurship in post-secondary education is traditionally better developed in ETF partner countries, with entrepreneurship in higher education generally well addressed. But higher education must better engage in the wider lifelong entrepreneurial learning drive. This will ensure that the necessary interfaces between entrepreneurship promotion in post-secondary education and third-level education are established. Secondly, good practice sharing in post-secondary entrepreneurship promotion can create scale and impact. More developed business-education cooperation can additionally foster innovation in the teaching and learning dynamic and in-turn respond better to the needs of local economies.

Specifically in third-level education, studies show that viable business ideas emerge from technical, scientific and creative studies where cross-campus cooperation drives innovation and entrepreneurship potential. Cross-campus entrepreneurship promotion ensures that students of all disciplines have access to entrepreneurship education – as opposed to entrepreneurship being the sole preserve of the economics or business faculty. This requires effective university leadership agenda as part of a wider bid to improve the employability and entrepreneurial potential of each nation's graduates and support strategies for student start-ups.

## **E –GOVERNANCE IN EDUCATION**

The Mission of the National e-Governance Plan (NeGP) is to focus on Education sector that Provide greater opportunities of access to higher education with equity to all eligible persons and in particular to the vulnerable sections. It can be extended to various existing institutions, new upcoming institutions supported by State Governments and Non-Government Organizations/civil society to supplement public efforts aimed at removing regional or other imbalances that exist at present. The plan can initiate policies and programs for strengthening research and innovations and encourage institutions – public or private – to engage in stretching the frontiers of knowledge. NeGP can promote the quality of higher education by investing infrastructure and faculty, promoting academic reforms, improving governance and institutional restructuring.

To expand the higher education sector in all its modes of delivery to increase the Gross Enrolment Ratio (GER) in higher education to 15% by 2011-12 and to 21% by XII Plan and 30% by the year 2020

- To expand institutional base of higher education (including technical, professional and vocational education) by creating additional infrastructure in existing institutions, establishing new institutions and incentivizing through state governments and Non-Governmental Organizations / civil society.
- To provide opportunities of higher education to socially deprived communities and remove disparities by promoting the inclusion of women, minorities and differently-abled persons.
- To remove regional imbalances in access to higher education by setting up of institutions in un-served and under-served areas
- To enhance plan support for infrastructure and faculty development in the institutions of higher learning and to attract talent towards careers in teaching and research.
- To create conditions for knowledge generation through improved research facilities in universities and colleges.
- To promote collaboration with International community, foreign governments, universities/institutions and regional and international institutions, for the advancement of universal knowledge and intellectual property rights.
- To promote autonomy, innovations and academic reforms in institutions of higher learning.
- To undertake institutional restructuring for improving efficiency, relevance and creativity in higher education.

Through implementation of e-governance solution is every unit of an academic institution, the real time information processing and knowledge management of the institution is made possible. E governance solution is an integrated solution that facilitates the processing and maintenance of large volumes of information, including student, faculty inventory, asset management, facility management, transport library, staff details and payroll and student fees among various departments in an academic institution.

E governance solution in the fields of educational sector incorporates whole data and processes of an educational Institution into a unified system, making the process



uncomplicated, well organized and error-proof. The solution is designed to make the system user friendly, time saving and cost saving also. Many of them are flexible enough to adapt the changing educational environment efficiently and quickly.

Educational Institutions may have various requirements that include computerization and , classes, timetable, transport, attendance library , salary and expenses, examinations, performance, grades, hostels, security and reports. Many of the software provide allow their clients to choose

### **DIGITAL SKILLS AND ENTREPRENEURSHIP**

Interfacing digital skills and entrepreneurship presents a critical opportunity for the next generation. Ways should be sought to capitalise upon the digital readiness of today's young people to encourage more technological start-ups. Young people need the training, confidence and support to enable them to exploit new technologies. Building digital skills through education and dedicating resources to promote '**webpreneurship**' are frontline EU policy concerns and are important policy references for ETF partner countries.

### **CAREER GUIDANCE**

All young people must understand entrepreneurship to make an informed career choice. The engagement of businesses with career guidance services that recognise and promote entrepreneurship as a viable labour market opportunity would encourage young people to consider self-employment and business development as their career path. Ensuring young people are prepared to take over and develop a family businesses must be part of this dynamic. Career guidance services in ETF partner countries, in cooperation with small business support organisations, could therefore have a critical role in supporting young people and family businesses with business succession.

### **START-UP SUPPORT**

In ETF partner countries, young people need more considered attention in the wider business start-up support effort. Overall, entrepreneurship difficulties in general are compounded by young people's limited life and work experience; and lack of capital. Start-up guidance, training and follow-up mentoring to early-phase young entrepreneurs may not only mitigate high-risk lending to young people by banks but also generate greater added value from their businesses. Without proper training and guidance, young people may enter into entrepreneurial endeavours which are high-risk and generate low added-value. SME support agencies should therefore consider 'one-stop' shops providing more 'packaged support (e.g. training and financial support, advisory and mentoring services for young people). The package approach would also need to be adapted to specific groups e.g. young women and immigrant youth. On finance, governments and lending institutions need to determine more viable options to finance young people's businesses, including reflection on the notion of tolerable risk. Packaged support to young entrepreneurs should give particular attention to success of loan repayments and business sustainability.

## **MENTORING**

A primary stumbling block for young entrepreneurs is the lack of business experience. Mentoring can address this through one-to-one professional support to build entrepreneurial confidence and know-how. Mentoring requires planning, financial investment, monitoring and evaluation. A number of questions need to be considered to ensure its effectiveness in differing cultural contexts. Is mentoring best when it is informal? What incentives are needed for mentors? And what background, preparation or training do mentors need specifically for supporting young entrepreneurs? Could virtual mentoring arrangements overcome geographical distances and/or social and cultural sensitivities (e.g. in communities where young women's access to mentoring and support is restricted)? Developments in youth entrepreneurship mentoring will require quality assurance and should include business ethics.

## **E-GOVERNANCE**

E-Governance is managed by using different technologies such as Wide Area Networks, Internet, and mobile computing. This has the ability to transform relations with citizens, businesses, and other arms of government. Besides above, it can serve a variety of different ends:

- Better delivery of government services to citizens
- Improved interactions with business and industry
- Citizen empowerment through access to information
- More efficient government management

Moreover, benefits can be less corruption, increased transparency, greater convenience, revenue growth, or cost reductions. Through implementation of e-governance in education sector the government will be able to find the solution to every unit of an academic institution, the real time

Information processing and knowledge management of the institution is made possible. E governance solution is an integrated solution that facilitates the processing and maintenance of large volumes of information, including student, faculty inventory, asset management, facility management, transport library, staff details and payroll and student fees among various departments in an academic institution.

It is established that E-governance brings in efficiency, effectiveness, transparency and accountability. The informational and transactional exchanges employing various technologies for speedy and positive outcome results with in government, between governments & govt. agencies of National, State, Municipal and Local levels, citizen & businesses.

Even the product life cycle is taken care of through R & D and innovation for enhancing product Quality features better than competitors to stay in race. The cost reduction measures through quality check on outsourced items has facilitated practically at no investment. With this, the enlargement of market share has been made possible. The merger and de-merger are purely on the basis of returns on capital investment.

### What is Digital India?

- To make India ready for a knowledge-based future.
- Focus of the Rs 1.13 lakh crore (appx. US\$ 17 billion) initiative is on using technology to create a participative, transparent and responsive government.



Providing high-speed internet, mobile phone and bank account enabling participation in digital & financial space; shareable private space on a public cloud, and creating a safe and secure cyber space.

Seamless integration across departments/jurisdictions  
Ensuring availability of services in real time from online and mobile platforms for ease of doing business, leveraging geographical information systems (GIS) etc.

Take digital literacy to the next level  
Providing digital resources in Indian languages, citizens not required to submit physical documents, etc.

Investments & Technology Promotion Division, Ministry of External Affairs, Govt. of India

### Nine Pillars of Digital India

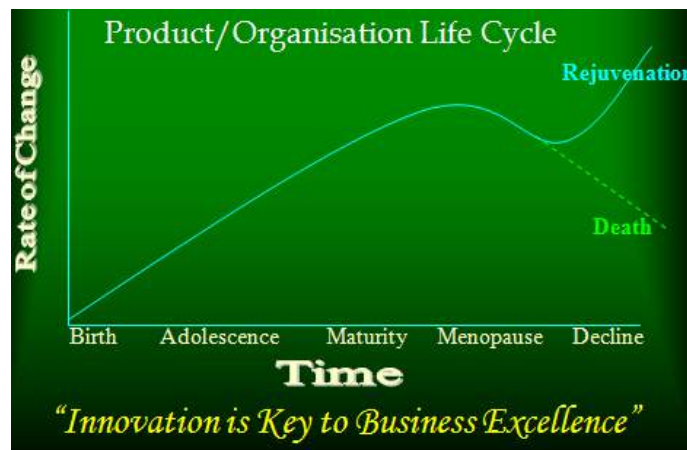

In simple terms, R & D is nothing but investing resources to generate new ideas and Innovation is implementing new ideas to generate money. This is being looked by all

Enterprises. The basic concept of any Entrepreneur is to create wealth with manageable risk and employing technology for quicker results with minimum investment.

For practical purposes, the PDCA cycle has the advantage of being cyclical implying that improvement never ceases. Plan-Do-Check-Act (PDCA cycle) is repeated till the original plan is achieved.

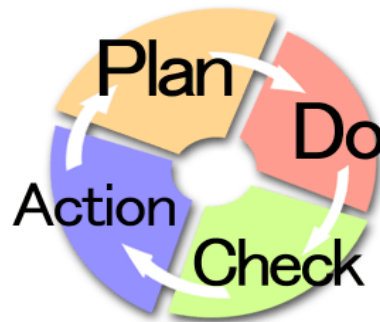

It is paramount for an enterprise to adopt 3P principle i.e. People, Planet and Profit as mantra for survival and growth since People play an important role in taking timely decision/action. Taking care of Planet through adoption of eco-friendly technologies and product goes a long way in ensuring good brand image in the market place and without profit no organization can sustain operations for a long.

### **WHAT IS ENTREPRENEURSHIP?**

Entrepreneurship is the process of creating something new with value by employing the resources in judicious manner after analyzing the entire gamut of designed product / service offerings for a specified sector which has large untapped potential and also to be able to penetrate into other areas for growth.

### **WHO IS AN ENTREPRENEUR?**

One who creates a new business in the face of risk and uncertainty for the purpose of achieving profit and growth by identifying opportunities and assembling the necessary resources to capitalize on them? Good Entrepreneurs are able to identify the growth opportunities that arise from the changes.

### **ENTREPRENEURSHIP DYNAMICS**

- Is a dynamic process of creating incremental wealth? This wealth is created by individuals who assume the major risks in terms of equity, time and career commitment of providing value for some product or service
- The entrepreneur must somehow infuse value to the product or service...

## ENTREPRENEUR ATTRIBUTES

Entrepreneur should possess following attributes

- Self-confident and optimistic
- Able to take calculated risk
- Respond positively to changes
- Flexible and able to adapt
- Able to get along well with others
- Knowledgeable of markets
- Independent minded
- Responsive to criticism

## MAJOR STAGES OF ENTREPRENEURSHIP

- Converging on the idea
- Business Plan
- Business Formation
- Growth/ Exit
- Going Public

### Converging on the Idea

In many cases, the decision start a business precedes the idea. Many ideas fall by the way side, since they are either technically not feasible or financially not viable or both. So, you need to do enough 'research' to converge on the idea

- Documentary
- Experience

### Business Plan Development: Four Major Elements are

- New Product/ Service Development
- Business Model
- Financial Model
- Operating Plan

## A FRAMEWORK TO THINK ABOUT IDEAS FOR ENTREPRENEURSHIP

	<i>Existing Product</i>	<i>Modified Product</i>	<i>New Products</i>
Existing Markets	Women's Shampoo	Alternative Greeting Cards	Solid state still camera
Identifiable Markets	Clothes for professional women	Overnight package delivery	Specialty sports car
New Markets	Mobile pet grooming device	Personal Computers	Laser discs

When it is required to Examine Growth/Exit option, the following criteria must be borne in mind since it is not strongest, nor the most intelligent who survives but those who are the most responsive to change as stated by Charles Darwin. It is imperative to consider all options including Business Process Re-engineering prior to arriving at decision to exit from business.

- Difference between stagnant and growing companies
- Growth will require resources
- Infusion of capital through internally generated funds
- Sometimes employment of venture capitalists
- Passive investors
- Growth will also require organization, as taught in BS

**For Knowledge Economy, Economic growth and wealth generation are driven by the acquisition and use of knowledge through:**

***Knowledge:***

- research skills
- information assessment skills
- ability to innovate
- ability to implement
- capacity to continuously learn

***Knowledge Economy is different than the Industrial Economy***

- This is the great edge that India has
- We have small window of opportunity and a chance to become world leaders in this domain Service industry is a corner stone of Knowledge economy

**And, Service Sector can benefit through:**

- Do not scorn at service industry
- In India service industry can be the driver for other industries
- Service Industry Sectors:
- Banking, insurance, education, finance, marketing, entertainment, leisure and so on.
- Today ITES (IT enabled services) is a multibillion dollar industry Very vital for the growth of Indian economy.

**For Product Industry to Grow:**

- Very vital for the growth of Indian economy.
- To be able to provide financial resources during expansion since manufacturing sector is capital intensive.
- Research input for New Product Development is the key to stay in business besides capacity enhancement from time to time.

- Development of markets with the changing needs of the consumers
- To be able to provide financial resources during expansion since manufacturing sector is capital intensive.
- Research input for New Product Development is the key to stay in business besides capacity enhancement from time to time.
- Development of markets with the changing needs of the consumers.

### Entrepreneurship: The Importance

- Central to the development of economy
- The Small and Medium Enterprises (SMEs) constitute over 90% of total enterprises in most of the economies.
- Employment generation
- SME sector accounts for about 39% of the manufacturing output and around 33% of the total export of the India (in term of value

### Entrepreneur and Manager

<i>Entrepreneur</i>	<i>Manager</i>
The main motive of an entrepreneur is to start a venture by setting up an enterprise. He understands the venture for his personal gratification	But, the main motive of a manager is to render his services in an enterprise already setup by someone else.
An Entrepreneur is the owner of the enterprise.	A manager is the employee in the enterprise owned by the enterprise
An entrepreneur being the owner of the enterprise assumes all risks and uncertainty involved in running the enterprise.	A manager doesn't bear any risk involved in the enterprise.
The reward an entrepreneur gets for bearing risks involved in the enterprise is profit which is highly uncertain	A manager gets salary as reward for the services rendered by him in the enterprise. Salary of a manager is certain and fixed.
He acts as an innovator or change agent.	He simply translate the entrepreneur's ideas into practice.

### LEAN MANAGEMENT SYSTEM ( LMS )

Lean Management System leads to lean organization where in lean manufacturing (procurement to After Sales Service ) is the core for attaining improved quality, higher throughput, better efficiency and higher productivity.

### LEAN MANUFACTURING SYSTEM

Lean Manufacturing System is systematic approach to identifying and eliminating waste (non- value added activities ) through continuous improvement by flowing the product only when the customer needs it. The need of LMS is:

- To meet the challenges of competing in globalised markets.

- Continued Market place focus on quality, cost, delivery and innovation due to ever increasing customer expectations.
- Pressure of outsourcing by OEM.

**Seven types of Wastes in Traditional System of Manufacturing**

- Waste due to non standardization and **variation** in production processes.
- Waste due to inadequate **capacity utilization**
- Waste due to **waiting time** of men, machines and material.
- Waste due to **unnecessary movement** of material
- Waste due to pre-process and in-process **inventory**.
- Waste in the **process itself** (due to excessive cycle time and consumption of direct material, indirect material & energy).
- Waste due to producing **defective goods** and unnecessary

**Some Examples of Wastes are**

Time a patient spends in a clinic

- Time one spends at airport
- Time to develop a particular vendor
- Time for which stores items are lying idle
- Time for any set up change

All the above would add significantly to cost, delivery time

Basic Objective of LMS is to do more and more with less and less human effort, less equipment, less time and less space. At the same time coming closer and closer to providing customers what exactly they want.LMS concentrates on business process time line.



LMS aims to reduce the time line by reversing the sequence of activities and eliminating non value added operations.

**ABOUT QUALITY FUNCTION DEPLOYMENT ( QFD )**

QFD is a scientific technique for translating the voice of customer with development of products and services. It is a complete product planning process as opposed to problem solving and analysis. The technique was invented by Akashi Fukuhara of Japan and first applied with very good results at Toyota.

**STEPS TO WORLD CLASS MANUFACTURING (WCM)**

The Next Generation Entrepreneur has to imbibe 7 steps as required in World Class Manufacturing Set up which forms basis to stay ahead with competitors



- Focus on competitive quality
- Implement Lean manufacturing
- Achieve cost efficiency
- Reduce time to market
- Exceed customer expectations
- Streamline outsourcing processes
- Have a global perspective

### **Focus on Competitive quality**

Today's dynamic and turbulent business environment has shifted the focus of the organizations from "Quality" to "**Competitive quality**". With ever changing customer requirements, quality is no more a competitive weapon. Every organization has quality today. What separates a world class organization from others is - how better you are from the rest of your competitors.

Everybody in the organization must think and demonstrate that they can do better. The need of the hour is to constantly **challenge the status-quo** and develop a constructive level of dissatisfaction with the present performance.

### **Implement Lean Manufacturing System**

Lean manufacturing is an overall methodology that seeks to minimize the resources required for production by eliminating waste (non-value added activities) that inflate costs, lead times and inventory requirements, and emphasizing the use of preventive maintenance ,quality improvement programs, pull systems and flexible work forces and production facilities.

Principles of lean include zero waiting time, zero inventory, scheduling (internal customer pull instead of push system), batch to flow (cut batch sizes), line balancing and cutting actual process times.

### **Achieve Cost Efficiency**

Although recent developments in planning and customer relationship management have focused more on top-line benefits (increased revenue), the bottom line is still greatly dependent on controlling costs. Companies with a lower operational cost structure enjoy an obvious advantage in profitability and the ability to adjust pricing to meet competitive pressures if necessary to maintain or gain market share.

Costs are really just part of the scoreboard. When a company implements world-class operational processes, it improves multiple measurements simultaneously, including cost, lead times, and inventory and customer service.

### **Reduce Time to Market**

Customers now penalize suppliers that infringe on their time, whether through delays, mistakes or inconveniences. Today's customers demand operations that are airborne, on-

line and real-time. Soon is not the answer the customers want to hear. They count the speed of response time as a Key Value Dimension.

Good ideas are not enough; well-managed processes for bringing new products to market faster than the competitors can lead to significant competitive advantages. Bringing products faster into the market does represent some element of risk, which can be properly evaluated.

### **Exceed Customers Expectations**

The ultimate key to success in any business enterprise is to please your customers. The most successful companies don't just meet customer expectations, they exceed them and beat the competition by setting the standards at a level that makes it difficult, if not impossible, for others to surpass.

### **Streamline Outsourcing Processes**

Outsourcing of manufacturing operations is a common practice today because it offers flexibility—the ability to change products or processes rapidly—and can often save money by exploiting economies of scale or other favorable cost factors the contractor has to offer.

For manufacturers, the fastest and easiest way to achieve this goal is through partnerships with companies that have attained superior capabilities in particular phases of the process-like production.

By partnering with world-class contract manufacturers you can reap the benefits almost immediately—well-managed processes, high quality, on time deliveries—and increase your performance and deliver to meet your customer's expectations. At the same time you can focus your own resources on things that you do best—product innovation, design, marketing, distribution sales or manufacturing.

### **Have a Global Perspective**

There's no question the world is shrinking, and virtually every business is now involved in some form of international trade—whether marketing and selling to customers in other countries or simply using parts or materials that are produced elsewhere. Customers today are looking for world class products.

Aims towards achieving manufacturing excellence by working towards a culture that involves:

- Zero defects
- Zero losses
- Zero accidents
- Zero breakdowns
- Zero pollution
- Zero customer complaints

There is QCDIP Model on which many companies are working. Here it is defined as:

Q. Quality and Quantity

- C. Cost
- D. Delivery and Speed
- I. Innovation and Intellectual Capital
- P. Productivity and Pride

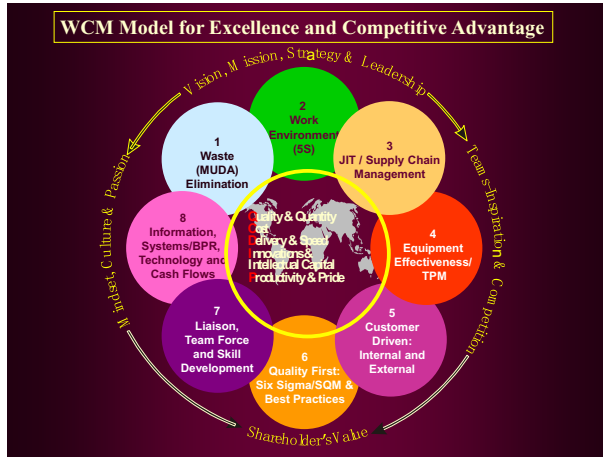

The companies wanting to become world class manufacturing must follow the international standards in quality. One of the best frame work to follow in this regard is The Shingo Prize which is awarded to companies who have attained manufacturing excellence.

## SIX SIGMA APPROACH FOR PERFORMANCE IMPROVEMENT

### What is Six Sigma?

*Six Sigma is a high performance data driven approach focused on analyzing the root causes of business problems and solving them.* It ties the outputs

3Sigma-	66810 defects/ million
4Sigma-	6210 defects/million
5Sigma-	233 defects/million
6Sigma-	3.4 defects/million

of a business directly to market place. Under the new approach, quality is a state in which value enrichment is realized for the customer and provided in every aspect of business relationship.

### Why Six Sigma?

- At the strategic level, the goal of Six Sigma is to align an organization to its market place and deliver real improvements to the bottom line.

- At the operational level, the Six Sigma goal is to move the business product or service attributes within the zone of customer specifications and to significantly shrink process variation.

### The Six Sigma Strategy affects following fundamental areas of Business

- Process improvement with significant reduction in defects
- Product & Service improvement for Customer satisfaction
- Design methodology for perfection with adequate tolerance to prevent failure
- Boundary less Collaboration for improvements at Supplier end

Six Sigma places a clear focus on getting pre-defined bottom line results in a given time frame. Company's Vision, Mission & Strategy form the basis for Six Sigma project identification. Goals for Six Sigma projects are established with baseline metrics. The meaning of a *Metric* being *Measure Everything That Results In Customer Satisfaction*. The projects are based on real data and observations and not on just opinions.

### Important Aspects of Six Sigma are

#### Process Elements :

- Analysis of variation
- Disciplined approach
- Quantitative measures
- Statistical methods
- Process improvement

#### Basic Phases :

- Define
- Measure
- Analyze
- Improve
- Control

#### Basic Tools used for Projects :

- Pareto Chart
- Brainstorming
- Cause & Effect Diagram
- Flow Chart & Check List
- Histograms / Scatter Diagram
- Stratification
- Run Chart/SPC Chart

In many growing companies world over, Six Sigma has helped in finding logical solutions of chronic problems by in-depth analysis of data for establishing correlation between multiple variables affecting productivity/cost/quality. It helps in identification of most prominent parameter affecting a particular attribute which can then be controlled and maintained in a particular range/band. This will not only help in improving quality but also consistency, benefiting external as well as internal customers.

The next generation Entrepreneur will require to be thoroughly conversant in using Innovation and Technology to further business interests without missing an opportunity besides employing all above stated tools religiously and to keep monitoring the performance in order to enlarge delighted customers base and also focus on new product development.

### REFERENCES

- [1] [www.ise.polyu.edu.hk/html/academic\\_program/ISE\\_syllabi/ISE6704.doc](http://www.ise.polyu.edu.hk/html/academic_program/ISE_syllabi/ISE6704.doc)
- [2] [www.benchmarksixsigma.com/Lean\\_Training](http://www.benchmarksixsigma.com/Lean_Training) [www.etf.europa.eu/webatt.nsf/0/.../\\$file/INFORM\\_19\\_Youth%20entrepreneurs.pdf](http://www.etf.europa.eu/webatt.nsf/0/.../$file/INFORM_19_Youth%20entrepreneurs.pdf)
- [3] <https://pdfs.semanticscholar.org/86a2/5b85bd3d577e2073f10d3ac00bebcd7f9007.pdf>

- [4] <https://fredericodeigah.wordpress.com/.../introduction-to-entrepreneurship-development..>
- [5] [www.yourarticlelibrary.com/entrepreneurship/entrepreneurship-development.../40707..](http://www.yourarticlelibrary.com/entrepreneurship/entrepreneurship-development.../40707..)
- [6] [www.sixsigma.com/six-sigma-tools/](http://www.sixsigma.com/six-sigma-tools/)
- [7] [www.sixsigma.com/six-sigma-certification-level/](http://www.sixsigma.com/six-sigma-certification-level/)
- [8] <https://www.irjet.net/ar>
- [9] [www.slideshare.net/hedaurahul/world-class-manufacturing-wcmchives/V3/i5/IRJET-V3I5500.pdf](http://www.slideshare.net/hedaurahul/world-class-manufacturing-wcmchives/V3/i5/IRJET-V3I5500.pdf) Koh, C.E., Prybutok, V.R. "The three-ring model and development of an instrument for measuring dimensions of e-government functions", *Journal of Computer Information Systems*,
- [10] Gartner Group, "Key Issues in E-Government Strategy and Management," Research Notes,
- [11] H. Dlamini, UNESCO Nairobi Office E-Governance and the promotion of Education.

# Cause-related Marketing in India: Effect of Cause Involvement on Purchase intention

VIVEK AGGARWAL<sup>1</sup> and VINOD KUMAR SINGH<sup>2</sup>

## Abstract

*Research into consumer responses to cause-related marketing (CrM) has grown in recent years. Through CrM social or environmental commitment of companies can be visible to its consumers and at the same time enhance brand equity and sales by differentiating their brands on the basis of association with social cause. The purpose of this research is to investigate role of consumer awareness about the CrM campaigns and consumer involvement with the social cause regarding purchase intention of consumer. A survey was carried out through a self administered questionnaire in the urban areas of Ghaziabad and Noida between males and females consumers. The results indicate that cause involvement effects the purchase intention of consumers and response towards the CrM campaign differs among male and female consumers.*

**Keywords:** *Cause-related Marketing, Cause Involvement, Corporate Social Responsibility, Gender, Purchase Intention.*

## INTRODUCTION

Campaigns linked with social causes create a value association between a brand and its consumers. They are likely to improve competitiveness of a company and at the same time helpful in improving the economic and social conditions in communities in which it operates (Porter & Kramer, 2011). Corporate social initiatives are major activities undertaken by a corporation to support social causes and to accomplish their promises towards Corporate Social Responsibility (CSR). Marketing play a important role in facilitating these type of trade which motivated by the fundamental understanding of what prospective partners to such an exchange might be looking for in return for their support (Sargeant ,2002).

Cause related marketing (CrM) campaigns are marketing campaigns through which organizations can increase their sales while appearing to enhance their focus on social responsibility. These are marketing campaigns in which company promises to contribute monetary to a support a cause for every sale that's created (Kotler & Lee, 2005). The CrM

---

<sup>1</sup> Research Scholar, Faculty of Management Studies, Gurukul Kangri Vishwavidyalaya, Haridwar.  
E-mail: aggrvivek@gmail.com

<sup>2</sup> Professor and former Head and Dean, Faculty of Management Studies, Gurukul Kangri Vishwavidyalaya, Haridwar.

become popular in 1980s after a successful CrM campaign by American Express Bank in which it promises to donate to the Statue of Liberty Restoration Project one penny for each credit card transaction and one dollar for each new credit card issued (Nan & Heo, 2007; Varadarajan & Menon, 1988) .

CrM campaigns can of various types such as traditional sales promotions (i.e. when donations are proportional to product sales), licensing agreements, sponsorships, joint issue promotions and in-kind contributions. The purest type of CrM is the unequivocal connection between the purchase of products or benefits and diverting the income to a cause or particular charity (Varadarajan & Menon, 1988).

Successful CrM not only affects consumers purchase intention, brand choice, and willingness to pay (Barone et al. 2007; Koschate-Fischer, Stefan, & Hoyer, 2012; Lafferty 2007), but also has a long-term positive effect on the brands, such as improving brand image (Nan & Heo, 2007; Shabbir et al., 2010).

There are many examples of cause-related marketing in India. Like P&G commits a donation for every purchase of its selected products which is to be allotted to projects focusing on providing basic education to children under the campaign “Shiksha” launched in 2005. Many of the companies like ITC, P&G, Idea, Aircel, Toyota, Nokia, changed the fate of many by their active involvement in socially beneficial activities and understanding their corporate social responsibilities well (India’s Top 50 Marketer Awards: Social Marketer, 2010).

**Table 1:** Examples of CrM Campaigns

<i>Cause and Campaign</i>	<i>Supported companies</i>
Education (Project Shiksha: Padhega India, Tabhi To Badhega India)	P&G
Education (Ek Kadam Pragiti ki Aur)	Nihar Shanti Amla
Health & Hygeine (Swachh Aadat, Swachh Bharat)	HUL
Social awareness (Jaago Re!)	Tata Tea

Consumers compare various factors while evaluating companies conducting CrM such as awareness of CrM campaign, involvement with cause, cause-brand fit, and attributions about why companies are engaging in CrM. These factors dominate their thinking and influence their responses towards CrM and the companies participating in it (Webb & Mohr, 1998).

Cause involvement is “the extent to which consumers feels a cause to be personally important” (Zaichkowsky, 1985) or simply as “relevance that the consumer feels in response to cause exposure.” Cause involvement of consumer also includes its experience, assumptions and perceptions regarding cause proposed in the CrM campaign. In fact it can help them to evaluate whether the CrM campaign conducted by company is a profit oriented or altruistic act which can significantly moderates its influence on consumer attitudes and behaviours towards the brand and can affect consumer’s purchase intention (Hajjat 2003; Landreth and Garretson 2007).

However, the effect of cause involvement in consumer response to the CrM campaign has been less studied in India. The present investigation examines the role of gender and cause involvement on consumer’s purchase intention.

## Review of Literature and Hypothesis

Intense competition, both locally and internationally, has forced business to adopt new strategies to develop a sustainable competitive advantage, while becoming more accountable for business expenditures CrM is one of such strategy. CrM has been got an increased research attention among researchers in various countries (Kotler & Lee, 2005; Nan & Heo, 2007; Patel, Gadhavi & Shukla, 2016; Sung & Lee, 2016) and can refer to marketing campaigns which involves commitment by the business to create a monetary contribution to a cause for every sale that's created (Kotler & Lee, 2005).

It's been observed that the CrM campaigns that are successful have led to drastic increase in sales (Varadarajan & Menon, 1988). The benefits of successful CrM initiatives for a company include the following: influencing new customers, rising product sales, creating and sustaining a positive brand identity (Kotler and Lee, 2005); enhancing corporate image, products and organizations differentiation, enhancing brand loyalty and sales (Adkins, 2005). Further it can be helpful in employees and team motivation, bringing business values to life, building relationships and loyalty, adding value, demonstrating organizational values and enhancing reputation and profile ( Adkins, 2005 ; Berger et al., 2007 ; Dowling, 2001).

But researches like Ferle, Kuber and Edwards (2013) , Pawlak and Zasuwa (2011) have a converse view on CrM and conclude that information regarding social initiative by an organization not results in more favourable consumer attitude towards it, this may be due reason that consumers already have positive attitude towards companies selected. The results obtained also shows social initiative can have negative perception about the company's actions (Smith & Stodghill, 1994).

CrM might have effect on behaviour of consumer on a large scale (Bhattacharya & Sen, 2003). According to research by Aggarwal and Singh (2016) CrM initiatives like CrM campaigns results in forming positive attitude of consumers towards the organization as well as higher purchase intentions. The personal characteristics of respondent may influence the way they how they evaluate a CrM offer and their purchase decision (Schiff & Bento, 2000).

Cause involvement also has been considered as the important factor in CrM influencing consumer attitudes and purchasing decisions (Grau & Folse, 2007; Hajjat, 2003; Trimble & Rifon, 2006; Webb & Mohr, 1998). Personal involvement or personal importance is often based on personal interests and values (Zaichkowsky, 1985). Personal importance is manifested as cause involvement which is the support of a cause because of personal experience or social norms (Hou, Du & Li, 2008).

Grau & Folse (2007) states that consumers participation in cause related marketing campaign will tend to be more for highly cause involve consumers. Further, they can easily identify the sponsor brand, had higher brand commitment and will donate more often to social causes which are personally important to them. However, consumers, who have low involvement in the social cause, might support the CrM campaign if the partnering brand is familiar to them, as they may want to enhance their identification with the cause supporter brand (Bigne-Alcaniz *et al.*, 2010).



Companies understand the importance of consumer involvement with the cause and they link their CrM messaging with relevant partners in order to better engage their target audience with the cause, and, through that, with their brand.

On the basis of review of literature the researchers have drawn the following hypothesis – There is a significant association between cause involvement and consumer's purchase intention.

## **METHODOLOGY**

For this study the CrM campaign of Procter and Gamble Co. (P&G) is selected which is one of the oldest and continuous campaign (running since 2005) , in which company promise to donate for the education of children through their project “Shiksha” as when consumer purchase the products associated with campaign (Ferle et al., 2013).

### **Participants and Procedure**

250 self administered questionnaires were distributed among graduate, postgraduate students and faculties of different colleges and universities of Ghaziabad and Noida by using the convenience sampling technique. Out of 250, 180 questionnaires were found to be useful for including in research giving response rate of 72%.

### **Instrument**

The data was collected using a questionnaire based on previous studies. The validity and reliability of scale was also measured through Cronbach's Alpha and KMO and Bartlett's test of sphericity which were 0.851 and 0.831 respectively (Field, 2009).

### **Cause Involvement**

The degree of cause involvement of respondents was measured using the 5 point Likert scale ranging from “1=strongly disagree” to “5=strongly agree” containing items adopted from various studies (Ćorić, & Dropuljić ,2015; Hou et al. ,2008).

### **Purchase Intention**

For measuring consumers' purchase intention scale was adopted from the research of Hou et al. (2008). The responses were recorded on a 5 point Likert scale with answers ranging from “1=strongly disagree” to “5=strongly agree”.

## **Results and Discussion**

Table 1 illustrates the descriptive statistics of the demographic information of respondents that involve 60% males and 40% females. Most of the participants aged from 20 to 29 (37%).

**Table 1:** The Demographic Profile of Respondents

	<i>Categories</i>	<i>Respondents</i>	<i>Percent</i>
Gender	Male	108	60.0
	Female	72	40.0
Age Group ( in years)	Below 20	37	20.6
	20 to 29	67	37.2
	30 to 39	56	31.1
	40 to 49	16	8.9
	50 and above	4	2.2
Educational Qualification	Graduate	46	25.6
	Post Graduate	57	31.7
	Doctorate	72	40.0
	Under Graduate	3	1.7
	B. Ed.	2	1.1
Employment Status	Student	83	46.1
	Salaried employee	76	42.2
	Self employed	21	11.7

The results of regression analysis of relation between cause involvement and consumers' purchase intention are shown in tables 2-3.

The **table 2** shows the adjusted R square value which indicates the percentage of variation in consumers' purchase intention caused by cause involvement. The adjusted R square value of .442 indicates that the variation in consumers' purchase intention up to 44% is caused by consumers' cause involvement.

Results in **table 3** show the value of F-test which indicates the fitness of model. From the table it was found that the proposed model is statistically significant as F (78.469) and  $p < .001$  thus leading to conclusion that there is relationship between cause involvement and consumers' purchase intention.

**Table 2:** Model Summary

<i>Model Summary</i>				
Model	R	R Square	Adjusted R Square	Std. Error of the Estimate
1	.669a	.448	.442	1.422

a. Predictors: (Constant), Cause Involvement

**Table 3:** ANOVA: Cause Involvement and Consumers' Purchase Intention

ANOVAa						
	Model	Sum of Squares	df	Mean Square	F	Sig.
1	Regression	160.931	1	160.931	78.469	.000b
	Residual	196.885	96	2.051		
	Total	357.816	97			

a. Dependent Variable: Purchase Intention

b. Predictors: (Constant), Cause Involvement

**Table 4:** Shows the contribution of cause involvement on consumers' purchase intention in the NCR region. The results of the t- value confirm that cause involvement ( $t = 3.865$ ;  $p = .000 < .005$ ) is significant at 0.05 level.

<i>Coefficients<sup>a</sup></i>						
<i>Model</i>		<i>Unstandardized Coefficients</i>		<i>Standardized Coefficients</i>		
1	(Constant)	B	Std. Error	Beta	t	Sig.
	Cause Involvement	3.583	.927		3.865	.000
	a. Dependent Variable: Purchase Intention	.600	.068	.671	8.858	.000

A linear regression equation between a dependent variable (Consumers' purchase intention) and independent variable (cause involvement) can be derived as:

$$PI = a + b CI \quad \dots (1)$$

The resulting regression equation is:

$$PI = 3.583 + 0.6 CI \quad \dots (2)$$

Where, PI = Purchase Intention

CI = Cause involvement

The equation (2) specifies that if cause involvement changes by one unit, there will be 0.6 units increase in the consumers' purchase intention. The positive value of coefficient cause involvement indicates the positive relationship between it and consumers' purchase intention.

## LIMITATIONS AND FUTURE IMPLICATIONS

There are a number of limitations associated with the current study. First, is that it has taken examples from only Fast Moving Consumer Goods (FMCG) as such the nature and type of response may vary in other Indian industry and the results cannot be generalized. Second, this research is based on self-reported responses; however, respondent's own willingness to purchase products supporting a cause may not actually do so in reality. Another concern is that, the sample size taken in the study is small for the results to be generalized in urban areas.

Various other demographic factors, such as income level and education, could also affect the response of consumers towards CrM campaign and also their purchase intention and hence such factors also need to be considered by future studies. Future research may also consider other independent variables besides CrM campaign like cause brand fit, consumer involvement, cause involvement etc.

The findings of this study can be directly or indirectly used by companies to create positive feeling towards their brand and develop and maintain long lasting relationships with consumers.

## CONCLUSION

It is important for marketers to understand why some consumers participate in CrM and others do not. For a successful CrM campaign managers can select social causes which match with the personality, lifestyles and values of targeted consumer (Varadarajan and Menon 1988; Patel, Gadhavi & Shukla, 2016).

The current study shows that cause involvement have a positive relation with purchase decision of consumers. The variation in consumers' purchase intention up to 44% is caused by cause involvement of the companies. These findings confirm the findings of existing literature, which proposed that the consumers' purchase intention is positively affected by cause involvement (Ćorić, & Dropuljić, 2015; Hou et al., 2008; Patel, Gadhavi & Shukla, 2016; Shabbir et al., 2010).

## REFERENCES

- [1] Adkins, S. (1999). *Cause related marketing: Who cares wins*. Oxford: Butterworth-Heinemann.
- [2] Aggarwal, V. & Singh, V. K. (2016) Influence of Cause related marketing campaigns on consumers' purchase intention: An empirical study in India. *International Journal in Management and Social Science*, 8(4), 512-5171
- [3] Barone M., Norman A. & Miyazaki A. (2007) Consumer response to retailer use of cause-related marketing: is more fit better? *J Retail*, 83(4), 437-445
- [4] Berger, I. E., Cunningham, P., & Drumwright, M. E. (2007). Mainstreaming CSR: Developing markets for virtue. *California Management Review*, 49 (44), 132 – 157.
- [5] Bhattacharya, C. B., & Sen, S. (2003). Consumer-company identification: A framework for understanding consumers' relationships with companies. *Journal of Marketing*, 67(2), 76-88.
- [6] Bigné-Alcañiz, E., Currás-Pérez, R., Ruiz-Mafé, C., & Sanz-Blas, S. (2012). Cause-related marketing influence on consumer responses: The moderating effect of cause-brand fit. *Journal of Marketing Communications*, 18(4), 265-283.
- [7] Ćorić, S. D., & Dropuljić, M. (2015). Consumers' attitudes towards cause-related marketing. *Annals of the Alexandru Ioan Cuza University-Economics*, 62(3), 343-356.
- [8] Dowling, G. (2001) *Creating corporate reputation: Image and promise*. Oxford University Press, Oxford, USA. 41, 257-278.
- [9] Grau, S. L., & Folse, J. (2007). Cause-related marketing (CRM): the influence of donation proximity and message-framing cues on the less-involved consumer. *Journal of Advertising*, 36(4), 19-33.
- [10] Field, A. (2005). *Discovering Statistics Using SPSS*. Sage publications.
- [11] Hajjat M (2003) Effect of cause-related marketing on attitudes and purchase intentions: the moderating role of cause involvement and donation size. *Journal of Nonprofit Public Sector Marketing*, 11(1), 93-109.
- [12] Hou, J., Du, L., & Li, J. (2008). Cause's attributes influencing consumer's purchasing intention: Empirical evidence from China. *Asia Pacific Journal of Marketing and Logistics*, 20(4), 363-380.
- [13] India's Top 50 Marketer Awards: Social Marketer (2010). *Pitch*, 8, 64-70.
- [14] Koschate-Fischer, N., Stefan, I. V., & Hoyer, W. D. (2012). Willingness to Pay for Cause-Related Marketing: The Impact of Donation Amount and Moderating Effects. *Journal of Marketing Research*, 49(6), 910-927.

- [15] Kotler, P., & Lee, N. (2005). *Corporate social responsibility: doing the most good for your company and your cause*. Hoboken, N.J: Wiley.
- [16] La Ferle, C., Kuber, G., & Edwards, S. M. (2013). Factors impacting responses to cause-related marketing in India and the United States: Novelty, altruistic motives, and company origin. *Journal of Business Research*, 66(3), 364-373.
- [17] Lafferty B (2007). The relevance of fit in a cause-brand alliance when consumers evaluate corporate credibility. *Journal of Bussiness Research*, 60(5), 447-453.
- [18] Landreth S, Garretson J (2007). Cause-Related Marketing (CRM). The influence of donation proximity and message-framing cues on the less involved consumer. *Journal of Advertising* 36(4):19-33.
- [19] Nan, X., & Heo, K. (2007). Consumer responses to corporate social responsibility (CSR) initiatives: Examining the role of brand-cause fit in cause-related marketing. *Journal of Advertising*, 36(2), 63-74.
- [20] Patel, J. D., Gadhavi, D. D., & Shukla, Y. S. (2016). Consumers' responses to cause related marketing: Moderating influence of cause involvement and skepticism on attitude and purchase intention. *International Review on Public and Nonprofit Marketing*, 13(27), 1-18.
- [21] Pawlak, M., & Zasuwa, G. (2011). Influence of a company's social initiatives on the consumer attitude towards it: Results of experimental research. *Contemporary Economics*, 5(2), 80-89.
- [22] Porter, M. E., & Kramer, M. R. (2011). Creating shared value. *Harvard business review*, 89(1/2), 62-77.
- [23] Sargeant, A. (2002). Social and cause-related marketing: The growth of a discipline? *Journal of Nonprofit & Public Sector Marketing*, 9(4), 13-15.
- [24] Schiff, A. D., & Bento, R. F. (2000). The use of financial and nonfinancial information for evaluating performance: an attributional perspective. *Journal of Applied Business Research*, 16(4), 47-62.
- [25] Shabbir, S., Kaufmann, H. R., Ahmad, I., & Qureshi, I. M. (2010). Cause related marketing campaigns and consumer purchase intentions: The mediating role of brand awareness and corporate image. *African Journal of Business Management*, 4(6), 1229.
- [26] Smith, G., & Stodghill, R. (1994). Are good causes good marketing? *Business Week*, 3363, 64-66.
- [27] Sung, M., & Lee, W. (2016). What makes an effective CSR program? An analysis of the constructs of a cause-related participant sport sponsorship event. *International Journal of Sports Marketing and Sponsorship*, 17(1), 56-77.
- [28] Trimble, C. S., & Rifon, N. J. (2006). Consumer perceptions of compatibility in CRM messages. *International Journal of Nonprofit and Voluntary Sector Marketing*, 11(3), 29-47.
- [29] Varadarajan, P., & Menon, A. (1988). Cause-related marketing: A co-alignment of marketing strategy and corporate philanthropy. *Journal of Marketing*, 52(3), 58-74.
- [30] Webb, D. J., & Lois A. Mohr (1998). A typology of consumer responses to cause-related marketing: From skeptics to socially concerned. *Journal of Public Policy and Marketing*, 17(2), 226-238.
- [31] Zaichkowsky, J. L. (1985). Measuring the involvement construct. *Journal of Consumer Research*, 12(3), 341-352.

# Mergers and Acquisitions – The way for Next Generation Transformation

RICHA AGRAWAL<sup>1</sup>

## ABSTRACT

*Mergers and Acquisitions have now become important features of corporate restructuring; they have been playing an important role in the external growth of a number of leading companies the world over. They have become popular because of the enhanced competition, breaking of trade barriers, free flow of capital across countries and globalization of business. This paper present an overview of M&As, and discuss various domains where M&As are beneficial. The focus of the paper is to discuss the impact of Mergers and Acquisition on the profitability of banks.*

**Keywords:** M&As, Profitability, Ratios, Banks

## INTRODUCTION

**Mergers and Acquisitions** (M&As) continue to be a significant force in the restructuring of the financial services industry. The Indian Commercial Banking Sector, which has played a pivotal role in the country's economic development, is currently passing through an exciting and challenging phase. With the onset of economic reforms, the banking sector in India has embarked upon mergers and acquisitions to capture the synergistic benefits like economies of scale and scope, in the face of increasing competition from domestic as well as foreign players and rapid technological developments. Several research studies examine merger related gains in banking and these studies have adopted one of the two approaches, based on either accounting information or market prices. Though mergers and acquisitions have become common in India today but, very little appears to be known about their profitability. Our study attempts to fill this gap in knowledge about mergers and acquisitions in India.

## REVIEW OF LITERATURE

Under this study, the researcher reviewed research papers and books for the purpose of providing an insight into the work related to mergers and acquisitions. After going through the available relevant literature on mergers and acquisitions (M&As) it comes to know that most of the work high lightened the impact of mergers and acquisitions on different aspects of the companies. A firm can achieve growth both internally and externally. Internal growth may be achieved by expanding its operations or by establishing new units, and external growth may be in the form of mergers and acquisitions, takeovers, joint ventures, amalgamations etc. Many studies have investigated the various reasons for mergers and

---

<sup>1</sup> Research Scholar, Department of EAFM , University of Rajasthan

acquisitions on the Indian financial service sector.

**V.K.Shobhana and Dr.N. Deepa(2011)**, in their article entitled to “Mergers and Acquisitions in Indian banking sector and pre and post merger technical efficacies-An empirical investigation” have examined technical efficiencies of the nine selected merged banks in the post reform period. The study uses stochastic Production Frontier Approach to measure the technical efficiency as a ratio of output and input. The study reveals that of the nine select cases of M&As, the merger deals of Union Bank of India and HDFC Bank only resulted in significant improvement in the technical efficiency.

**Dutta and Dawn (2012)**, in a paper “Merger and acquisitions in Indian banks after liberalization An analysis” investigates the performance of merged banks in terms of its growth of total assets, profits, revenue, deposits, and number of employees. The performance of merged banks is compared taking four years of prior-merger and four years of post-merger. The study findings indicate that the post-merger periods were successful and saw a significant increase in total assets, profits, revenue, deposits, and in the number of employees of the acquiring firms of the banking industry in India.

**Mahesh R. & Daddikar Prasad (2012)** focused on the performance of Indian Airline Companies after the consolidation of Airline sector in year 2007-08. The main objective of this paper is to analyze whether the Indian Airline Companies have achieved financial performance efficiency during the post merger & acquisition period specifically in the areas of profitability, leverage, liquidity, and capital market standards. The finding of this study shows that there is no improvement in surviving Company’s return on equity, net profit margin, interest coverage, earning per share and dividend per share post-merger & acquisition.**Dr. Konstantin’s Agorastos et al (2012)** applied examined the effects of mergers and acquisitions (M&As) of acquiring firms in Greece among different industries using accounting data (financial ratios). The main objective of this paper is to evaluate the post merger performance of Greek listed firms in the Athens Stock Exchange. The results revealed for the examined firms of each industry different result per industry and that there is after their M& As, in general, a worsening at the post-merger performance. From this it could be presumed that their post-merger performance was affected by their different industry type.

**Jagrithi kumar (school of economics, University of Madras, (2013)** stated that mergers are combination of two or more corporate entities, and in the process of combining of two or more such corporate entities lose their corporate existence. Acquisitions are that type of business transaction where the shares or control of a company is taken over by the acquiring company. Researcher stated that the competition commission (CCI) of India has drawn the reserve bank of India’s (RBI’s) attention to distortion in banking due to limited presence of the private sector and high entry barriers for foreign banks Government policy can be the one of the major forces in banking consolidation. As a result of the Asian financial crisis, the Government of regions has promoted consolidation of the banking system on the basis that this would contribute to the stability of the Banking system.

**V.Radha Naga Sai and Dr.Syed Tabassum Sultan (2013)** in their article entitled to “christened has financial performance analysis in the banking sector; a pre and post merger perspective” have made an attempt to evaluate financial performance of the selected two

banks based on the financial ratios from the perspective of pre and post merger. To analyze the impact of merger paired t-test was applied to the various financial ratios for before and after merger data relating to Indian overseas bank and HDFC bank.

## **RESEARCH METHODOLOGY**

### **Objective of the study**

The broad objective of this study is to measure the impacts of Mergers and acquisitions on financial profitability of ICICI Bank with Bank of Rajasthan. The objectives of the study are mentioned as under.

1. To study the performance of Mergers and acquisitions on the Profitability of the ICICI Bank.

### **Hypothesis of the study**

1. To test the significant difference between pre and post merger profitability.  
H<sub>0</sub>: There is no significant difference between pre and post merger profitability.  
H<sub>a</sub>: There is a significant difference between pre and post merger profitability.

### **Variables used for research are**

The variables to examine and evaluate the impacts of mergers and acquisitions on the profitability position of selected bank are:-

- 1 Gross profit margin
- 2 Net profit margin
- 3 Operating profit margin
- 4 Adjusted gross margin
- 5 Interest spread
- 6 Return on net worth

## **SAMPLE SIZE**

As such the universe of the study is the Indian public and private sector banks; the researcher selected Bank of Rajasthan with ICICI bank merger.

## **PERIOD OF THE STUDY**

The researcher have made an attempt to study the impact of Mergers & Acquisitions on the profitability of ICICI Bank by using the available information for the period 2005-06 to 2015-16

## **DATA ANALYSIS**

For secondary data analysis, the researcher has used paired-t-test. Paired-t-test is a statistical technique that is used to compare two population means in the case of two samples that are



correlated. Paired sample t-test is used in 'before-after or when the samples are matched pairs, or when it is a case control study. It is considering an appropriate test for judging, the significance of a sample mean. It can also be used for judging the significance of the coefficient of simple and partial correlations. The relevant test statistic is calculated from the sample data and then compared with its problem value based on T-distribution at a specified level of significance for concerning degrees of freedom for accepting or rejecting the null hypothesis.

**Table:** Pre and Post Merger Mean of Profitability Ratios of ICICI Bank

<i>Profitability Ratio of ICICI Bank</i>					
ICICI BANK		Mean	SD	t value	P value
Operating profit margin_ ICICI	PRE	16.64	3.94	1.534	0.164
	POST	13.37	2.69		
Gross profit margin_ICICI	PRE	13.90	2.49	1.194	0.267
	POST	11.85	2.93		
Net profit margin_ICICI	PRE	12.30	2.80	-6.098	0.000
	POST	20.97	1.50		
Adjusted cash margin_ICICI	PRE	14.85	4.31	-1.703	0.127
	POST	18.21	0.97		
Interest spread_ICICI	PRE	3.37	0.40	-16.744	0.000
	POST	7.32	0.35		
Return on net worth_ICICI	PRE	12.58	4.50	0.280	0.787
	POST	11.96	1.90		
	POST	7.32	0.35		
	POST	11.96	1.90		

## ANALYSIS OF RESULTS

The above table shows the profitability position of ICICI Bank in pre and post merger conditions. From the observation of the above table, it is evident that there is a significant increase in net profit margin and interest spread after merger ( Pre merger mean of net profit margin 16.64 and post merger mean of net profit margin is 13.37,  $p < 0.05$  similarly pre merger mean of Interest spread 3.37 and post merger mean 7.32,  $p < 0.05$ ) but in case of operating profit margin, gross profit margin, Return on net worth and adjusted cash margin there is no any significant changes.

## CONCLUSION

On the basis of analytical study of Bank of Rajasthan merger with ICICI Bank, the following conclusions have been drawn which are perfectly in line of objectives predetermined:

1. From the shareholders point of view of profitability the sample company attained positive results in the post merger period.
2. From a longer perspective a consolidated company would be able to better cope up with competition increased pressure to cut cost and grow in the changing business environment.

## **SUGGESTIONS**

The present study is an attempt to study the financial implications and its implications on the employees of banking companies before and after M& As. The scope proposes that mergers and acquisitions throw tremendous opportunities for future research with respect to:

1. The study with similar objectives could be made with reference to another sectors like IT sectors, manufacturing sector etc.
2. The study with similar objectives could be made from time to time.
3. The study for liberalizing the economic, political and legal procedure for merger could be made.
4. The study with similar objectives on the demerger decision of companies of different sectors could be made.

The study, in spite of all the above difficulties and limitations, has fulfilled its objectives and its findings and conclusion are universal in nature.

## **BIBLIOGRAPHY**

- [1] Sudhir Chowdhary. (2001), “**Cellular Phone Service: The Call of Merger**”, *Effective Executive Journal*, Vol. III, No. 8, pp. 53- 55.
- [2] Sumanta Dutta and Pankaj Baag (2009) “**Understanding Mergers and Acquisitions**” *The Accounting World*, Han. 2009, PP.21 – 25.
- [3] Surjit Kumar (2002), “**A study of corporate takeovers in India**”, Ph.D. thesis abstract Submitted to University of Delhi, pp.1-11.
- [4] Swaminathan S (2002), **Indian M&As: why they have worked So Far**”, *Indian Management*, pp. 72-77. Times Research Foundations, Pune
- [5] V. Gangadhar and G Naresh Reddy (2007) “**Mergers and Acquisitions in the Banking Sector – An Empirical Analysis**” *ICFAI Reader*. March 2007. PP.42 – 48
- [6] V. Pawaskar (2001) “**Effect of Mergers on corporate performance in India**” ,
- [7] *Vikalapa*, vol.26, No1. January –March, pp19-32.
- [8] Varsha Virani (2007) “**Impact of Mergers and Acquisitions on private Sector banks in Global Economy**” *Mergers and Acquisitions*. Oct. 2007, PP. 47 – 50.

## **WEBSITES**

- [1] [www.cmie.org](http://www.cmie.org)
- [2] [www.sebi.gov.in](http://www.sebi.gov.in)
- [3] [www.bseindia.com](http://www.bseindia.com)
- [4] [www.rbi.org](http://www.rbi.org)
- [5] [www.indiainfo.com](http://www.indiainfo.com)
- [6] [www.ssrn.org](http://www.ssrn.org)
- [7] [www.nseindia.com](http://www.nseindia.com)
- [8] [www.scribd.com](http://www.scribd.com)
- [9] [www.ijrcm.org.in](http://www.ijrcm.org.in)
- [10] [www.moneycontrol.com](http://www.moneycontrol.com)
- [11] [www.sify.com](http://www.sify.com)
- [12] [www.money.rediff.com](http://www.money.rediff.com).

# A Study on Consumer Online Shopping Behaviour

SMITA DRON<sup>1</sup>

## Abstract

*The main goal of the paper is to explore the impact of e-commerce on consumer behavior and quantitative describing the actuality of internet shopping in the case of the India in order to explain the development of internet shopping and its impact on consumer behavior. The paper build on the relevant literature and at the same time examines consumer behavior by questionnaires. The main goal of the paper is to explore the impact of e-commerce on consumer behavior and describing the actuality of internet shopping in the case of the India in order to explain the development of internet shopping and its impact on consumer behavior. The paper build on the relevant literature and at the same time examines consumer behavior by questionnaires. Online retail or e-commerce is transforming the shopping experience of customers. Also the result of the study shows that internet consumer trust and perceived risk have strong impacts on their purchasing decisions.*

*E-commerce encompasses the entire world of electronically based organizational activities that support a firm's market.*

*The result of the study shows that internet consumer trust and perceived risk have strong impacts on their purchasing decisions.*

**Keywords:** *E-commerce, Internet Shopping, Consumer Behavior, Privacy and Security, Consumer Trust*

## INTRODUCTION

The internet is being developed rapidly since last two decades, and with relevant digital economy that is driven by information technology also being developed worldwide. After a long term development of internet, which rapidly increased web users and highly speed internet connection, and some new technology also have been developed and used for web developing, those lead to firms can promote and enhance images of product and services through web site. Therefore, detailed product information and improved service attracts more and more people changed their consumer behavior from the traditional mode to more rely on the internet shopping. On the other hand, more companies have realized that the consumer behavior transformation is unavoidable trend, and thus change their marketing strategy. As the recent researches have indicated that, the internet shopping particularly in business to consumer (B2C) has risen and online shopping become more popular too many people. There are many reasons for such a rapid developing of internet shopping, which

---

<sup>1</sup> Research Scholar, Bundelkhand University, Jhansi  
E-mail: dsmitadron@yahoo.com

mainly due to the benefits that internet provides. First of all, the internet offers different kind of convenience to consumers. Obviously, consumers do not need go out looking for product information as the internet can help them to search from online sites, and it also helps evaluate between each sites to get the cheapest price for purchase. Furthermore, the internet can enhance consumer use product more efficiently and effectively than other channels to satisfy their needs. Through the different search engines, consumers save time to access to the consumption related information, and which information with mixture of images, sound, and very detailed text description to help consumer learning and choosing the most suitable product (Moon, 2004).

However, internet shopping has potential risks for the customers, such as payment safety, and after service. Due to the internet technology developed, internet payment recently becomes prevalent way for purchasing goods from the internet. Internet payment increase consumptive efficiency, at the same time, as its virtual property reduced internet security.

Consume behaviour is the study of individual or groups and the process they use to select a product or service that satisfy their needs. The behaviour of customers is different in both online and physical.

In modern world the popularity of internet is increasing rapidly. Today people are doing business online which has made life much easier. The online retailing is becoming an integral part of an economy and country and worldwide increasingly seeing trust and confidence in purchasing online. E commerce is gaining several advantages by increasing user comfort online shopping experience. Online customers seek for new products, attractiveness and price compatibility. They use internet for price comparisons, search information about a product etc. which means they don't have limits to shop online. The online shopping depends upon factors like shopping incentive, shopping motive, internet knowledge and so on.

Online shoppers wants to gain maximum information with minimum clicks and reach information which suits their requirement such as best brands and best price and offers. E-Commerce also provides benefits to the channel partners. By using E-Commerce, the dealers of the products can save on the selling expenses. Transaction cost in between producers to ultimate consumers will reduce which they can use for expanding their business. Mode of payment is also very much consumer friendly by many online companies where the consumer need not use his/her debit or credit card due to the lack of trust and security. In this case companies are allowing Cash On Delivery (COD) and deliver the product at their doorstep.

### **DIFFERENCE BETWEEN ONLINE/OFFLINE STORES**

Even the internet shopping has been rapidly developed, especially in consumer goods industry, but there still have a big difference between traditional and online consumer shopping. Referred to sales in the Indian consumer goods industry, the online sales occupied at a very low percentage rate. That could be caused by many reasons, but the most importance is the advantages exist in both traditional shops and online market; both of them have specific characteristics. For example, the traditional seller can provide

convenience in parking and shopping, it allows customers come to read and check the quality of goods before they purchase, and the after service is more directly to customers. However, the traditional store has limited number of goods, and the selling cost is higher than online store. By comparison, we can find out the limitations of traditional store are more likely as the advantages of online store, in contrast, the weakness of online store is also seems as the advantages of traditional store. It is clear from the overview of internet and internet shopping development that e-commerce is being used in many corporations due to the dramatic development of technology and competitive advantages of web selling. Moreover, the expansions of the usage by individuals also become main contributors to the development of internet shopping. Relatively few studies have investigated in the internet shopping and impact on consumer behavior. The previous studies are more focus on the marker's point of view, such as how to establish a more efficient marketing channel online rather than the offline.

## **THEORITICAL FRAMEWORK**

Online retail attributes are categorized into four

(i) merchandising; (ii) customer service and promotion; (iii) navigation and convenience; and (iv) security.

Out of these four attributes the customer service and security are the important pillars that online retail stands upon. The major differences in online and offline retail are in online the customer will not be able to touch and feel the product. But in order to contradict these factors the customer service in online retail was made strong. Customer service include sales clerk for merchandise answering FAQ's and credit and payment policy etc.

The online retailers do advertisements just like offline retailers. The advantage that online retailers have is that the cost of advertisement will be very low since the ads will be in digital form. Moreover they follow the concept of viral buzz marketing. The online shopping experience will enable the customer to reduce their decision making time by providing a variety of selections. In online store the customer enjoys certain added facilities like product comparisons, reviews by customers who have used the product and also enjoys offers and discounts.

The concept of switching cost is also important. Switching cost is the cost involved when the customers change his buying pattern. When the customers move from offline to online purchase it is to be noted that the cost involved for him is zero. The customers find more convenient in online since no search cost and travelling is there. From the hypothesis from literatures it's been found that the customers who buy online are more committed is related to information satisfactory and relational benefits. The information about the product and its reviews is an important factor which decides customer decision.

The different patters seen in customers are Browse offline buy online, browse online buy offline, complexity and consumers who browse online and buy online.

Online consumers are always seeking new products, new attractiveness and the most important thing being price compatibility with their budget. The internet is the best way to save time and money through purchasing online within their range of budget at home or in

anywhere. Online consumers don't have limits to online shopping. They also use internet for comparison of prices of goods and services, news, visit social networks and search information and so on. The factors that differentiate between online and offline retail are:

- Convenience: By purchasing online the customer wants just to log into an online shopping portal and just type a product that he wants in search bar. This reduces the cost of searching for a product.
- Low price: The price of products in online store is low compared to other retail stores. Since there is no cost of marketing and the margins are very low in online retail.
- Payments: The customers can make the payments through online by the use of credit or debit cards.
- Availability: Today, with the advent of mobile devices the shopping has become much easier. One of the ways in achieving the consumer value is through understanding the customer need. The online stores have portals where the customer can make any suggestion that customer wants. Now there are websites where one can customise his product for e.g. one can send an images which can be printed in T shirts, as laptop skins etc.

The offline revenue impact of the informational website critically depends on the product category and customer segment. Customer in a specific segment will reduce their shopping trips and online actions substitute for physical store experience. The search cost and transaction cost determines the difference. They directly the consumers' reservation and their readiness to pay for it. The price limits whether a product will be accepted, or if it will be bought the lasting question is where to buy, which is also determined by the price.

A well informed customer will be able to get a product at best price. This will lead to competition joint with better learned consumers is the foundation of falling prices in the online retail. The Internet suggest full information and will allows consumers to come up with the most economic decision.

The product promotion through the online selling/marketing turns out to be a better than offline selling. The website is an online marketing medium as well as advertising content.

The external and internal factors influence customers mind. According to Warner external factors are Demographics, socio-economics, technology and public policy; culture; sub-culture; reference groups; and marketing. The internal factors include perception motivation and self-image.

The consumers have two types of motives, which are functional and non-functional. Time, shopping place, consumers need, parking area and lower cost of products are functional. The nonfunctional are related with brand name and social and cultural values.

Potential consumers reach their purchase decision in two ways. Initially, consumers typically screen a large set of products in order to identify a subset of promising alternatives. They then evaluate the subset in greater depth, performing comparisons across many products based on some necessary attributes and make a purchase decision.

## METHODOLOGY

For this study, we have followed the following methods for data collection.

Questionnaire: Questionnaire with 100 respondents from STEP-HBTI campus who have purchased any product from online.

This study intends to involve the both types of data. i. e the primary data and secondary data.

Secondary Data- The Secondary data is collected Through books, Journals, Report, Research studies, Research Articles, Socio-Economic survey, Magazines .

This study confined to the period from 2015 and Kanpur city.

The primary data has been collected from students between the age of 18 and 26 with open and closed ended questionnaire.

The data have been collected from 100 respondents from STEP-HBTI campus with both open and closed ended questionnaire. The respondents are students who do online purchasing.

Analysis shows that consumers/clients take online purchasing decision on the following basis: price comparison, convenience, security, seasonal and other offers and availability of the product.

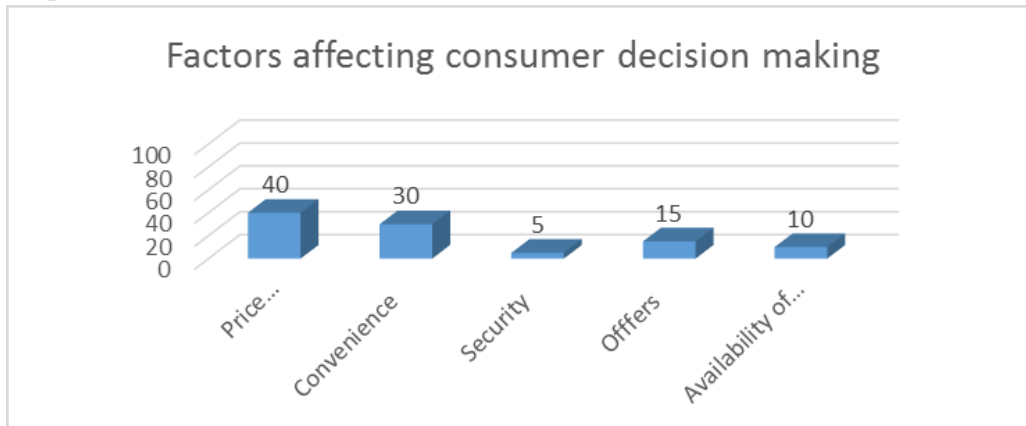

The graph shows that price comparison (40%) and perceived convenience (30%) are the key driving factors in the decision making of online consumer. This study also states that 5% respondent have a preference on security, 15% on various offers and 10% on availability of the product.

In summary, we can say that

- The factors that make the customer choose between online and offline is convenience and price is the major driving factors.
- The price of electronic products is low because there is no intermediary.
- The most common buying found in customers is Browse offline, buy online.

## **CONCLUSION**

The online shopping is becoming a trend among Indians as they experience it is more comfortable, time saving and convenient. When consumers make a purchase online, they are affected by various factors, including price, trust, and convenience. Price is much lower on the online stores compared to brick and mortar shops.

Intermediaries, physical storage, etc. are not present in online stores thus it can assist its clients with reasonably priced merchandise. The ease and comfort provided by these stores for 24x7 have made very easy shopping for consumers worldwide.

A survey was conducted to know the impact of the various factors on consumers. The result indicated that reduced price and convenience are the influential factors for customers to buy online.

Customers often are taken aback from purchasing online when it comes to touch and feel of the goods. The current trend in India is “browse offline and buy online”. Customers browse various products in physical stores to have a touch and feel of the product and later they buy them online to get it in reduced price. People compare prices in online stores and then review all feedbacks and rating about the product before making the actual purchase.

## **REFERENCES**

- [1] Rakesh, Sapna (2012), Impact of promotions and value consciousness in online shopping behaviour in India, Promotions in online stores, volume no 5, issue 2, pg: 60
- [2] Ramcharan, Mohan (2010) Key factors effecting consumer buying behaviour, the customer perception, volume no 2, issue 3, pg: 381Croome, R J (2013) Online-Offline Channel Switching Behaviour of Retail Consumers, Towards a Model of Consumer Value, Volume 1, issue 1, pg: 58
- [4] danaher j. peter, wilson w. isaac and davis a. robert (2003) a comparison of online and offline consumer brand loyalty, volume 22, issue 4, pg.: 461



# Women Entrepreneurship-Need of Today

MEENAKSHI SHARMA<sup>1</sup>

## ABSTRACT

*The term Entrepreneur covers people who have vision and ability and are fit for changing over vision without hesitation for the benefit of the general public. Because of changes sought after in the Market, there is an extension for a class of individuals on substantial scale who can change over the accessible assets into great of society, called Entrepreneurs.*

*In this way, people who have expertise, activity and imaginative thoughts for high undertakings in business, and essential characteristics of an Entrepreneurship is going out on a limb and making the fundamental speculation under the states of volatility. Business is a procedure of understanding openings in market, with a view to make riches for oneself through a lawful element. A cozy relationship exists amongst circumstance and individual needs. To be an Entrepreneurial open door, a prospect must meet two tests: it must speak to an attractive future state, including development or if nothing else change and the individual must trust it is conceivable to achieve that state. Along these lines, Entrepreneurship is comprehended by, being imaginative, chance taking, alert, adaptable, development arranged, innovative, beginning and working new pursuits.*

*This is the ideal opportunity for Women to wander into the Entrepreneurial world. Women lead organizations are profoundly expanding in the economies of all nations. The concealed entrepreneurial possibilities of women have step by step been changing with the developing affectability to the part and monetary status in the general public. Ability, Knowledge and versatility in business are the principle purposes behind women to develop into business wanders. Women Entrepreneur is a person who acknowledges testing part to meet her own needs and turn out to be financially free. A powerful urge to accomplish something positive is an inbuilt nature of entrepreneurial women, who is fit for contributing qualities in both family and social life. With the coming of media, women know about their own attributes, enjoyed each line of business from pappad to power links. The difficulties and openings gave to the women are women of computerized period are developing quickly that the employment searchers are transforming into occupation makers. They are prospering as planners, inside decorators, exporters, distributors, piece of clothing producers and as yet investigating new roads of financial interest. In India in spite of the fact that women constitute most of the aggregate populace, the entrepreneurial world is still a male commanded one.*

*Why Women make magnificent Entrepreneurs in the Digital Age? How Women are ruling the business visionary's scene and is utilizing their aptitudes to succeed. As circumstances are difficult for everybody, more families are moving towards double salary*

---

<sup>1</sup> Associate Professor, Tecnia Institute of Advanced Studies, Affiliated to GGSIPU, New Delhi

*families. Additionally innovation headways are making a virtual work environment feasible for women, who are hoping to adjust family and their profession.*

*In the advanced scene, women have a tendency to have certain abilities that make an upper hand. Women Entrepreneur has solid Communication Skills and Social Intelligence. They are Great Listeners, and are Lean toward Lower Risk. A dynamic Entrepreneurship segment is one of the different variables for success of economy which is important to use the riches and advancement limit of the created nations.*

*This paper demonstrates and stresses the Women Entrepreneurs as the possibly rising HR in the 21st century to beat the monetary difficulties in worldwide point of view.*

## INTRODUCTION

Women claimed businesses are exceptionally expanding in the economies of all nations. The concealed entrepreneurial possibilities of women have bit by bit been changing with the developing affectability to the part and monetary status in the general public. Ability, information and versatility in business are the principle explanations behind women to rise into business wanders. 'Women Entrepreneur' is a man who acknowledges testing part to meet her own needs and turn out to be monetarily free. A powerful urge to accomplish something positive is an inbuilt nature of entrepreneurial women, who is fit for contributing qualities in both family and social life. With the appearance of media, women know about their own particular attributes, rights and furthermore the work circumstances. The biased based impediments are smashed and women are discovered enjoyed each line of business from pappad to power links. The difficulties and openings gave to the women of advanced period are developing quickly that the occupation searchers are transforming into employment makers. They are prospering as creators, inside decorators, exporters, distributors, article of clothing producers and as yet investigating new roads of monetary interest. In India, in spite of the fact that women constitute most of the aggregate populace, the entrepreneurial world is still a male commanded one. Women in cutting edge countries are perceived and are more unmistakable in the business world.

In nineteen seventies, Women business started in its genuine sense. At this point, the original after Independence had finished their instruction. Taught women to satisfy their yearnings and desire started settling on independent work. This was a dynamic stride not removed from impulses or defenselessness, but rather with enthusiasm to improve an existence. In this decade, women were on the move time frame. They couldn't turn out completely from conventional exercises of caring for home, their in-laws, guardians, spouses and kids. At the same time they need to get into self-ruling monetary exercises.

Nineties saw an ocean change in women enterprise area. These were the times of the leap forward for women to end up business visionaries in many fields. They created mettle to make fresh starts. Guardians additionally built up reasoning. The customary routine of making just offspring as a business accomplice in family possessed organizations, (law of Inheritance supporting this), guardians began their own consultancy houses, giving diverse sorts of specialized administrations. Guardians began taking their female youngsters as accomplices in their organizations. Government additionally upheld this new thinking by making corrections to Succession Act.

Enactments said that both male and female have meet rights in the acquired property. This combined with expert training made young women to get into independent work. Many got to be accomplices in their family claimed business. Great number of woman specialists opened their own particular facilities. Building graduated began their own particular consultancy houses, giving distinctive sorts of specialized administrations. They likewise got into administration ranges like CA, Advocates, Hospitality business and great number opened secretarial workplaces. Great rate of women took to private venture exercises. Today we can see numerous women business visionaries in private venture.

In prior Five year arranges, women business idea was not fundamentally considered. Just in late plans, especially following Eight Five Year Plan, "Women Empowerment" idea came to lime light. From this arrangement onwards, women began chipping away at new wildernesses. The new era of women did not think on the lines of their moms. They expressed creating autonomous exercises. They had desires and aspirations. Taking to independent work was not out of impulse or powerlessness. It turned into a craved decision of numerous women to outline and build up their own venture.

Women began believing that independent work as a fundamental part of their life. They began thinking on the lines choosing their own particular vocations. Receiving own occupation for money era without going astray much from the social framework is turning into a key calculate a woman's life. Other than having home and kids, women have begun deduction to have a free occupation. While tolerating the conventional individuals conduct, from more established era, women today expect comprehension and support from their spouses and kids to have their word related decision. As business people, women need their voice to be heard as pioneers, as they are fit for adding to the development and achievement of their endeavor.

In any case, the Indian women entrepreneurs are confronting some real imperatives like -

- (a) **Lack of certainty:** as a rule, women need trust in their quality and ability. The relatives and the general public are hesitant to remain next to their entrepreneurial development. To a specific degree, this circumstance is changing among Indian women but then to confront an enormous change to build the rate of development in business enterprise.
- (b) **Socio-social hindrances:** Women's family and individual commitments are now and again an awesome boundary for prevailing in business profession. Just couple of women can oversee both home and business effectively, sufficiently giving time to play out every one of their obligations in need.
- (c) **Market-arranged dangers:** Stiff rivalry in the market and absence of versatility of women make the reliance of women entrepreneurs on go between key. Numerous representatives think that it's hard to catch the market and make their items prevalent. They are not completely mindful of the changing economic situations and subsequently can viably use the administrations of media and internet.
- (d) **Motivational components:** Self inspiration can be acknowledged through a mentality for a fruitful business, state of mind to go out on a limb and conduct

towards the business society by caring the social duties. Different variables are family support, Government strategies, budgetary help from open and private organizations and furthermore the earth appropriate for women to build up business units.

- (e) **Knowledge in Business Administration:** Women must be instructed and prepared continually to gain the aptitudes and information in all the useful regions of business administration. This can encourage women to exceed expectations in choice making process and build up a decent business network.
- (f) **Awareness about the money related help:** Various organizations in the monetary part expand their greatest support as motivations, advances, plans and so on. That being said each lady business visionary may not know about all the help gave by the establishments. So the earnest endeavors taken towards women entrepreneurs may not achieve the business people in rustic and in reverse ranges.
- (g) **Exposed to the preparation programs:** Training projects and workshops for each sort of business person is accessible through the social and welfare affiliations, in view of term, ability and the motivation behind the preparation program. Such projects are truly valuable to new, country and youthful business people who need to set up a little and medium scale unit all alone.
- (h) **Identifying the accessible assets:** Women are reluctant to discover the entrance to cook their requirements in the money related and advertising regions. Disregarding the mushrooming development of affiliations, organizations, and the plans from the administration side, women are not ambitious and element to upgrade the assets as stores, resources humanity or business volunteers.

Especially, in fact sound and professionally qualified women ought to be empowered for dealing with their own business, instead of subject to wage work outlets. The unexplored gifts of young women can be recognized, prepared and utilized for different sorts of enterprises to build the efficiency in the modern part. An attractive domain is essential for each lady to instill entrepreneurial values and include incredibly in business dealings.

Engaging women entrepreneurs is fundamental for accomplishing the objectives of reasonable improvement and the bottlenecks blocking their development must be destroyed to entitle full support in the business. Aside from preparing programs, Newsletters, coaching, exchange fairs and presentations additionally can be a hotspot for entrepreneurial improvement. Thus, the coveted results of the business are immediately accomplished and a greater amount of profitable business openings are found. From this time forward, advancing business enterprise among women is surely an alternate way to quick monetary development and advancement. Give us a chance to attempt to take out all types of sexual orientation segregation and along these lines permit “women” to be a business visionary at standard with men.

### **Women Entrepreneurs in the Digital Age**

“Why Women Make Excellent Entrepreneurs in the Digital Age”, 2010 was the first run through ever there were a greater number of women in the work constrain than men. As far as

women claimed organizations, in the vicinity of 1997 and 2011 there was a half increment, while male-possessed business just developed by 25% (American Express report). Women are overwhelming the business visionary scene and are utilizing their aptitudes to succeed. As circumstances are difficult for everybody, more families are moving towards double salary households.(as advised above with push and force elements). Likewise, innovation progressions are making a virtual work environment feasible for women, who are hoping to adjust family and their vocation. By making a more manageable condition, adaptability is attainable.

### **Women' Competitive Edge**

In the computerized scene, there is a more grounded development in women business visionaries than men, they could utilize these aptitudes, and many actually have, to make progress. The reviews led by numerous researchers with reference to Women focused edge; trusts women have a tendency to have certain aptitudes that make an upper hand like,

- Solid Communication Skills and Social Intelligence
- Great Listeners
- Aggressive
- Energized
- Tolerance
- Assurance to Excel
- Synergistic
- Incline toward Lower Risk

Do women' firm correspondence and social aptitudes make them more prepared to flourish in our post-modern advanced age? So, do women have particular aptitudes - whether the consequence of science or social molding - that can help them prevail as business visionaries?

The survey of writing uncovers, helping business people and entrepreneurs dispatch their brands, It is vigorously accepted there are a few generally "ladylike" initiative qualities that are more noteworthy now than any time in recent memory.

### **5 reasons why women make extraordinary business people in the advanced period**

1. Women have firm relational abilities and social insight. The computerized economy requires these aptitudes, and women appreciate a slight edge over their male partners.
2. Women make great audience members. Regardless of whether because of science or social molding, women have a tendency to be better audience members and are more grounded at drawing individuals into discussion. This means a few favorable circumstances for the business visionary, who can better adjust herself to client needs and construct more powerful groups of representatives, contractual workers and accomplices. Truth be told, numerous women business visionaries regularly depict building their business as building a group.

3. Women team up. Women have functioned admirably together since the most punctual female ventures, regardless of whether separating grains in the town or working in sewing honey bees. A 2009 Time magazine article by Claire Shipman and Katty Kay says, “[Women are] agreement manufacturers, conciliators and partners, and they utilize what is known as a transformational authority style - intensely connected with, motivational, to a great degree appropriate for the developing, less various leveled work environment.” The article, entitled “Women Will Rule Business,” referred to projections from the Chartered Management Institute in the UK. Looking ahead to 2018, CMI trusts the work world will be more liquid and virtual, and the interest for female administration abilities will be more grounded than any time in recent memory.

Virtual working environments and carefully portable ways of life give trying women business visionaries the adaptability to accomplish the harmony amongst work and family. Computerized instruments imply that women can now assemble a business from home and make one of kind work routines. Risk avoidance may run as one with inspirations for beginning a business. A recent report from the Small Business Administration (*Are Male and Female Entrepreneurs Really That Different?*) watches the contrasts amongst male and female business visionaries in the U.S. The outcomes found that male proprietors will probably begin a business to profit, and have higher desires for their business. Women will probably organize that business and individual lives work in congruity.

4. The advanced age offers an abundance of generally safe open doors. Wanders like blogging, electronic administrations, web based business and programming improvement require littler upstart expenses than assembling based, physical sort organizations. Cloud-based apparatuses and virtual workforces additionally bring down the cost of passage, making beginning a business more doable as well as agreeable for hazard opposed business visionaries.
5. The up and coming era of business people resisting the financial pattern by returning qualities at the heart of business. Also, women are giving men a keep running for their cash. The effective female social business people as good examples for women in business and trying female business people. Not at all like, women who set up and maintain a business with a social or group object are as far reaching as their male partners. At the danger of summing up, women have a genuine favorable position in authority that may be an incredible preferred standpoint in the business world. They can act and lead while staying tuned into their associates. Being sufficiently certain to utilize that is critical. Women pioneers shouldn't attempt to be part of the gang. They can utilize their characteristic endowments further bolstering their good fortune. Women who are driving fruitful social undertakings are good examples for women contemplating setting up their own business. In the present atmosphere social undertaking is flourishing and these motivating women demonstrate that estimations of cooperation and enthusiastic knowledge that women regularly bring as pioneers can help manufacture fruitful and strong organizations. A hefty portion of our graduates who began with a thought and ablaze enthusiasm and have formed

into driving female social business visionaries in India and we trust their examples of overcoming adversity will help other people with a thought to make it happen.

## **CONCLUSION**

Business is directly the most talked about and empowered idea everywhere throughout the world to beat financial difficulties. Women being the fundamental orientation of the general populace have extraordinary limit and potential to be the supporter in the general monetary improvement of any country. In this manner, projects and arrangements should be redone to not simply energize enterprise and execute systems which can help bolster entrepreneurial culture among youth. Media can possibly assume the most key part in entrepreneurial improvement by making and highlighting every such stage which can draw out the innovativeness and advancement among the women and men to develop business enterprise culture in the public arena. Creating nations are certainly in desperate need to support women enterprise as women workforce is immediately accessible to misuse the unexplored measurements of business endeavors. Created countries ought to principally concentrate on entrepreneurial instructive projects keeping in mind the end goal to create women business people. As a rule, internationally business world has acknowledged and is dealing with war balance to make enterprise as the last solution for defeat a wide range of business and market challenges.

# Corporate Governance: An Emerging Trend towards Global Market Economy

SUBROTO GANGULY<sup>1</sup> AND CHANDRANI GANGULY<sup>2</sup>

## Abstract

*Corporate governance mechanisms have been an important issue of enquiry for the researchers in financial economics. Both theoretical models and empirical analysis have been developed in this area to explain the occurrence of different contractual mechanisms and their efficacy in terms of improving managerial performance. A related issue in this literature is the independence and competence of the Board of Directors. The Indian corporate scenario was more or less stagnant till the early 90s but, after the liberalization of the 90s, the position and goals of the Indian. Corporate sector changed a lot. Overall, the conclusion seems to be that corporate governance is still in a very nascent stage in the Indian industry. The decision and policy making is still taken mostly as a routine matter. Among the institutional investors also, it seems that the FIIs are the most consistent in stock picking whereas the performances of the domestic institutional investors are sporadic and volatile at best. This is also serious shortcoming on the part of the capital market, not being able to enforce better governance on the part of the directors or performance on the part of the managers.*

**Keywords:** *Corporate Governance, Capital Market, FDI, Industrial Policy, Equity, Utilization of Capital*

## INTRODUCTION

“Corporate Governance mechanisms are economic and legal institutions that can be altered through the political process – sometimes for the better.” – Shleifer & Vishny (1997). Even if we agree that competition is the best mechanism for achieving economic efficiency through cost minimization, as predicted by the ‘evolutionary view of economic changes’ (Alchian, 1950, Stigler, 1958), the importance of Corporate Governance cannot be overlooked if we keep in mind issues like informational asymmetries and agency problems. The agency problem, stemming essentially from the separation of ownership and control is the backbone of the contractual view of the firm (Coase, 1937, Jensen & Meckling, 1976 and Fama & Jensen, 1983). In most cases an investment project is financed and managed by separate people. The financier and the manager/entrepreneur enter into a contract. But, as the contractual view notes, it is impossible to specify all future contingencies in the contract, and hence complete contracts are not feasible. The decision making power in case a situation not specified in the contract arises is referred to as the

---

<sup>1</sup> Associate Professor, Delhi Metropolitan Education, Noida

<sup>2</sup> Professor, Delhi Metropolitan Education, Noida



residual control – this is addressed to in the theory of ownership. Corporate governance and economic developments are intrinsically linked. Effective corporate governance systems promote the development of strong financial systems-irrespective of whether they are largely bank-based or market-based –which, in turn, have an unmistakably positive effect on economic growth and poverty reduction.

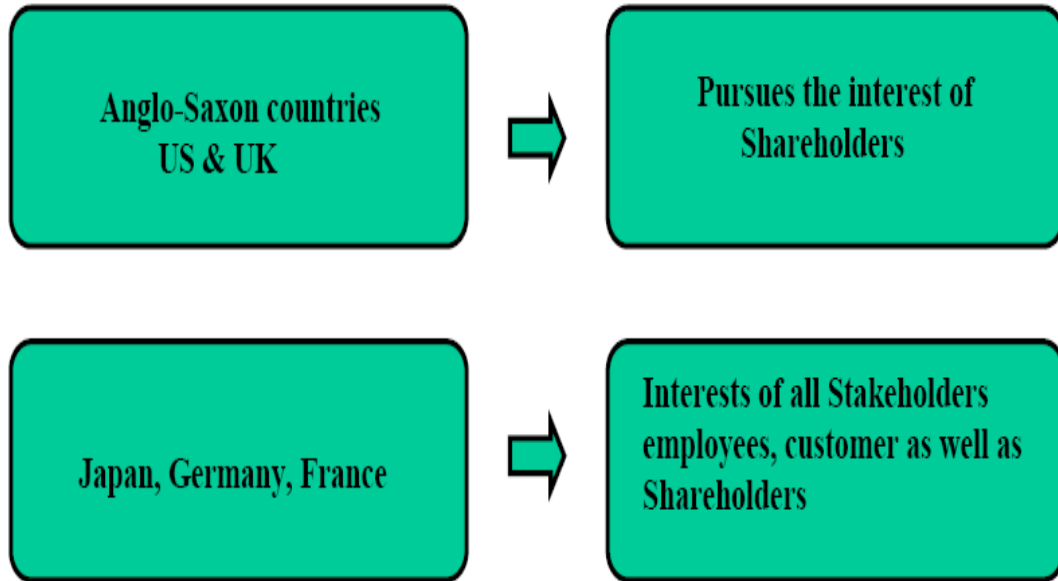

### **CORPORATE GOVERNANCE**

- A means whereby society can be sure that large corporations are well-run institutions to which investors and lenders can confidently commit their funds.
- Is a term that refers broadly to the rules, processes, or laws by which businesses are operated, regulated, and controlled? The term can refer to internal factors defined by the officers, stockholders or constitution of a corporation, as well as to external forces such as customer groups, clients and government regulations.
- (Creates).Safeguards against corruption and mismanagement, while promoting fundamental values of a market economy in democratic society.
- Considering the ethical failures in the last several years and the resulting crisis in confidence).A sincere commitment to creating and sustaining an ethical business culture in public and private sectors.

Corporate governance are the policies, procedures and rules governing the relationships between the shareholders, (stakeholders), directors and managers in a company, as defined by the applicable laws, the corporate charter, the company's bylaws, and formal policies. Primarily it is about managing top management, building in checks and balances to ensure that the senior executives pursue strategies that are in accordance with the corporate mission. It consists of a set of processes, customs, policies, laws and institutions affecting

the way of a corporation is directed, administered or controlled. Corporate governance governs the relationship among the many players involved (the stakeholders) and the goals for which the corporation is governed.

### THE INDIAN SCENARIO

- The Indian corporate scenario was more or less stagnant till the early 90s.
- The position and goals of the Indian corporate sector has changed a lot after the liberalization of 90s.
- India's economic reform programme made a steady progress in 1994.
- India with its 20 million shareholders is one of the largest emerging markets in terms of the market capitalization.

There has been a recent focus on corporate governance among the financial researchers worldwide and in particular in India. The main issue seems to be the independence of nonexecutive directors (The Hindu, 2001, several articles) 2.

Indian industry is now witnessing the transition from sinecures (hand picked directors) to professionally competent and independent non-executive directors on the board, but this will not be easy. Very few such competent people are in supply. Any suitable candidate needs to have a public stature to inspire confidence in the Shareholders. He should also be able to contribute to the company and not merely contest the management. Ideally, they should be prominent industrialists and not friends or promoters of the manager. The change of goals and facets of the Indian corporate have been significant.

The Scenario in the pre-liberalization period: was very depressing as demand always exceeded supply due to government imposed quotas, "licenses". This was supposed to check the extent of control owned by single individuals.

The main issues facing a CEO at that period was

- Where to invest excess cash?
- How to acquire more capacity?
- How to improve capacity utilization?

The corporate culture devolved around the managers oiling the bureaucrats / ministers for licenses. This attitude percolated through the corporate sector. Quality and price was not market determined (as demand always exceeded supply) which resulted in low quality, cost ineffective technology. Also the consumers were not aware of the gap between international and domestic standards of products and services.

After the liberalization, consumers now have a choice. The Indian market is large and hence very attractive. As a consequence MNCs flooded the market. The companies from the developed countries, where they were facing a saturated market came to invest in India either as green field ventures (Samsung), acquiring an Indian business (Coca Cola, Heinz) or Joint Ventures (JVs) (Pal – Peugeot, Tata – IBM). Initially JV was most popular, but that changed later (splits like Premier Automobiles – Automobile Peugeot, Tata and IBM, DCM and Daewoo) (See Roy chowdhury and Roy chowdhury, 2001 for an interesting theoretical discussion on the issue of JV life cycle.).

In the Indian condition, often the key was cheap labour, and hence the importance of having good senior management who were very aware of local conditions was great. Public sector units (PSUs) came under huge threat.

The management came under pressure to show efficiency and profitability. And there was considerable brain drain – all the brighter PSU employees went to the private sector as job opportunities boomed. Family owned businesses were forced to turn professional or enter into contractual arrangements with larger houses.

Roy (1999) studied Takeovers and Mergers (T&M) in India: one important instrument of corporate governance. She used data from CMIE for the years 1995 – 7. She observed that the mergers were mostly horizontal (allocation efficiency motive) of loss making or performance deteriorating companies, mostly within same business group.

A possible motive for this could be that Liberalization in the 90's worked as a threat of competition from the MNCs, which triggered T&M as response from the domestic companies.

They were facing resource constraints in terms of both

- Human Capital (internal labour market) and
- Finance (external selection)

Now mergers within same group imply that financial resource increase is smaller. So human capital is apparently the main motive behind these T&M activities.

### **CORPORATE GOVERNANCE OF INDIA HAS UNDERGONE A PARADIGM SHIFT**

- In 1996, Confederation of Indian Industry (CII) took a special initiative on Corporate Governance.
- The objective was to develop and promote a code for corporate governance to be adopted and followed by Indian companies, be these in the Private Sector, the Public Sector, Banks or Financial Institutions, all of which are corporate entities.
- This initiative by CII flowed from public concerns regarding the protection of investor interest, especially the small investor, the promotion of transparency within business and industry
- A National Task Force was set up. The Task Force presented the draft guidelines and the code of Corporate Governance (Desirable Corporate Governance Code) in April 1997(at the National Conference and Annual Sessions of CII.
- Since 1974, CII has tried to chart new path in terms of the role of an Industry Association such as itself. It has gone beyond dealing with the traditional work of interacting with Government of policies and procedures, which impact on industry.
- CII has taken initiative in Quality, Environment, Energy, Trade Fairs, Social Development, International Partnership Building etc. as part of its process of development and expanding contribution to issues of relevance and concern to industry.

## SECURITIES AND EXCHANGE BOARD OF INDIA

The Government of India's securities watchdog, the Securities Board of India, announced strict corporate governance norms for publicly listed companies in India.

The Indian Economy was liberalized in 1991. In order to achieve the full potential of liberalization and enable the Indian Stock Market to attract huge investments from foreign institutional investors (FIIs), it was necessary to introduce a series of stock market reforms.

SEBI established in 1988 and became a fully autonomous body by the year 1992 with defined responsibilities to cover both development and regulation of the market.

- On April 12, 1988, the Securities and Exchange Board of India (SEBI) was established with a dual objective of protecting the rights of small investors and regulating and developing the stock markets in India.
- In 1992, the Bombay Stock Exchange (BSE), the leading stock exchange in India, witnessed the first major scam masterminded by Harshad Mehta.
- Analysts unanimously felt that if more powers had been given to SEBI, the scam would not have happened.
- As a result the Government of India (GOI) brought in a separate legislation by the name of '**SEBI Act 1992**' and conferred statutory powers to it.

Since then, SEBI had introduced several stock market reforms. These reforms significantly transformed the face of Indian Stock Markets. SEBI asked Indian firms above a certain size to implement Clause 49, a regulation that strengthens the role of independent directors serving on corporate boards. On August 26, 2003, SEBI announced an amended Clause 49 of the listing agreement which every public company listed on an Indian stock exchange is required to sign. The amended clauses come into immediate effect for companies seeking a new listing.

## INDUSTRIAL POLICY AND FOREIGN INVESTMENT

The industrial policy introduced in July 1991 achieved a dramatic overhaul of regulations governing foreign investment. Government approval for equity investments of up to 51 percent in 35 industries covering the bulk of manufacturing activities is automatic. Requests to increase equity stakes beyond 51 percent still require approval from the Government's Foreign Investment Promotion Board. All sectors of the Indian economy are now open to foreign investors except those with security concerns such as defense, railways, and atomic energy.

### Industrial Policy

The government's liberalization and economic reforms programme aims at rapid and substantial economic growth and integration with the global economy in a harmonized manner. The industrial policy reforms have removed the industrial licensing requirements, removed restrictions on investment and expansion, and facilitated easy access to foreign technology and foreign direct investment.

## FOREIGN DIRECT INVESTMENT

Government wishes to facilitate foreign direct investment (FDI) and investment from Non-Resident Indians (NRI)s including Overseas Corporate Bodies (OCBs), that are predominantly owned by them, to complement and supplement domestic investment. Investment and returns are freely repatriable, except where the approval is subject to specific conditions such as lock in period on original investment, dividend cap, foreign exchange neutrality etc. as per the notified sartorial policy.

## CONCLUSIONS

As Indian companies compete globally for access to capital markets, many are finding that the ability to benchmark against world-class organizations is essential. For a long time, India was a managed, protected economy with the corporate sector operating in an insular fashion. But as restrictions have eased, Indian corporations are emerging on the world stage and discovering that the old ways of doing business are no longer sufficient in such a fast-paced global environment. Corporate governance mechanisms have been an important issue of enquiry for the researchers in financial economics. The agency problem of the problem due to the separation of ownership and control, which is starkly manifested in the corporate sector, is discussed in this literature. Both theoretical models and empirical analysis have been developed in this area to explain the occurrence of different contractual mechanisms and their efficacy in terms of improving managerial performance. Mechanisms like performance sensitive pay, employees' stock option; insider ownership has been tested and researched extensively. A related issue in this literature is the independence and competence of the Board of Directors. This is also a target of considerable attention in recent years. The Indian corporate scenario was more or less stagnant till the early 90s while the "license raj" was prevalent and the oiling culture was pervasive. But, after the liberalization of the 90s, the position and goals of the Indian corporate sector changed a lot. The consumers got an upper hand in the face of stiffer product market competition where the MNCs also participated. Among the institutional investors also, it seems that the FIIs are the most consistent in stock picking whereas the performances of the domestic institutional investors are sporadic and volatile at best. This is also serious shortcoming on the part of the capital market, not being able to enforce better governance on the part of the directors or performance on the part of the managers. Due to the lack of systematic data, we have been unable to analyze the efficacy of alternative incentive mechanisms for the managers directly. With the recent surge of attention to this area of research, probably more detailed data on such variables will become available in future and researchers will be able to look at this issue more closely.

## REFERENCES

- [1] Alchian, A. (1950): *Uncertainty, Evolution and Economic Theory*, Journal of Political Economy, 58, 211 – 21.
- [2] Baker, G. M. Jensen and K. Murphy (1988): *Compensation and Incentives: Practise versus theory*, Journal of Finance, 43, 593 – 616
- [3] Bhandari, L., S. Dasgupta and S. Gangopadhyay (2000): *Development Financial Institutions*

*as Financial Intermediaries,*

- [4] Brealey, R.A. and S.C. Myers (1997): *Principles of Corporate Finance*, Tata McGraw Hill.
- [5] Cadbury Report (1992): *The Financial Aspects of Corporate Governance*, Burgess Science Press.
- [6] Campbell, J.Y., A.W. Lo and A.C. Mackinley (1996): *The Econometrics of Financial Markets*, Princeton University Press, Princeton, New Jersey.
- [7] Carhart, M.M. (1997): *On Persistence in Mutual Fund Performance*, Journal of Finance, 52, 57 – 82.
- [8] Chibber, P.K. and S.K. Majumdar (1999): *Foreign Ownership and Profitability: Property Rights, Control and the Performance of Firms in Indian Industry*, Journal of Law and Economics, 42, 209
- [9] Coase, R. (1937): *The Nature of the Firm*, *Economica*, 4, 386 – 405.
- [10] Coase, R. (1960): *The Problem of Social Cost*, Journal of Law and Economics, 3, 1 – 44.
- [11] Conyon, M.J. and G.V. Sadler (2001): *CEO Compensation, Option Incentives and Information Disclosure*, Review of Financial Economics, 10, 251 – 77.
- [12] Denis, D.K. (2001): *Twenty-five Years of Corporate Governance Research... and Counting*, Review of Financial Economics, 10, 191 – 212.
- [13] Fama, E. and M. Jensen (1983): *Separation of Ownership and Control*, Journal of Law and Economics, 26, 327 – 49.
- [14] Hull, R.A. and J. Mazacheck (2001): *Junior-for-Senior Announcements: A Study of the Role of Inside Ownership*, Review of Financial Economics, 10, 213 – 25.
- [15] Sarkar, J. and S. Sarkar (1999): *The Governance of Indian Companies*, in K.S. Parikh (Ed.) India Development Report, 1999-2000, Oxford University Press, New Delhi.
- [16] Sarkar, J. and S. Sarkar (2000): *Large Shareholder Activism in Corporate Governance in Developing Countries: Evidence from India*, International Review of Finance, 1, 161 – 94.
- [17] Shleifer, A. and R. Vishny (1997): *A Survey of Corporate Governance*, Journal of Finance, 52,



## Authors Index

Agarwal, Prachi	324	Kadam, Monika	73
Aggarwal, Vivek	485	Kalchuri, Raghvendra Singh	388
Agrawal, Richa	493	Kansal, Payal	102, 107
Ahlawat, Abha	290	Katiyar, Alok	150
Ahmed, Ateeq	410	Kaur, Kamaljeet	80
Arora, Akansha	84	Khan, Suha	176, 180
Arrawatia, Mini Amit	324	Kumar, Arvind	233
		Kumar, Ashok	252
Bakshi, Tanvi	176, 180	Kumar, Naresh	415
Bansal, Deepak	49	Kumar, Om	290
Bartarya, Gaurav	262	Kumar, Pradeep	137
Bhadauria, Namit Singh	262	Kumar, Ranjan	311
bhargava, Antika	383	Kumar, Sachin	233
Bhaskar, Meenakshi	352	Kumar, Sandeep	290
Bhatia, Harish	137	Kumar, Santosh	184
Bhatnagar, Paras	133	Kumar, Shammi	91
		Kumarz, Someh	23
Chakraborti, Jayanta	376		
Chauhan, Prashant	133	Mahato, Basanta	244
Chhabra, Seema	388	Mallick, Bhawna	442
		Mathur, Deeksha	468
Dron, Smita	498	Maurya, Sushil	376
Dubey, Anjali	3	Maurya, Sushil K	107, 358
		Maurya, Sushil Kumar	426
Ganguly, Chandrani	511	Mishra, Apeksha	333, 343
Ganguly, Subroto	511	Mishra, N.L.	119
Goyal, V.K.	328	Mishra, Pankaj	405
Gujrati, Rashmi	15	Mishra, Pradeep Kumar	119
Gupta, Akshit	31	Misra, Vikas	369
Gupta, Avdhesh	168, 176, 180, 432		
Gupta, Himanshi	286	Pandey, Pallavi	41
Gupta, Piyush	426	Pandey, Sushant	453
Gupta, Priyanka	286	Pandit, Jyotsna	91
Gupta, Rajat	203	Pathak, Piyus Kumar	282
Gupta, Rajive	209	Payal, Lalita	290
Gupta, Shivangi	432	Pipara, S.S.	468
Gupta, Sonal	31	Prabha, M. Chandra	307
		Pradeep	303
Jain, Garima	442		
Jain, Rubil	150	Raina, Raj Lakshmi	69
		Rathee, Ashima	352



Sachan, Abhishek	209	Soni, A.K.	150
Saini, Shrutika	168	Srivastava, Anand Prakash	102, 107
Saxena, Sachin	328	Srivastava, Sripal	3
Shanker, Ravi	328	Srivastava, Vivek	415
Sharma, Anashul	23	Surbhi, Sarvendra Kumar,	269
Sharma, Apoorva	226		
Sharma, Deepti	369	Tewari, Sanjana	393
Sharma, Meenakshi	504	Tiwari, D.N.	364
Sharma, Nirmal	358	Tiwari, Kiran	364
Sharma, Pankaj	226	Tiwari, Mukta	191
Sharma, Ritu	141	Tiwari, Mukta	197
Sharma, Shailja	159	Tiwari, Shikha	297
Shukla, Sushil	297	Tripathi. Pragya	184
Sijariya, Rajeev	61		
Singh, Ashok Kumar	282	Upadhyay, R.S.	328
Singh, Devendra	252		
Singh, Dhananjay	221	Vashisht, Anil	405
Singh, Manish	399	Verma, Sarvachan	303
Singh, Shivansh	191, 197		
Singh, Vijai	141	Yadav, Ambica	221
Singh, Vikas	184	Yadav, M.K.	269
Singh, Vinod Kumar	485	Yadav, Neha	73
Singh, Yaduvir	303	Yadav, Santosh Kumar	415

The Next Generation is anticipated to be the most promising as well as demanding generation. Technology and Management - content, complexity and practice faces an imperative to maintain equilibrium. Such a scenario, emphasizes the fact that there are, and going to be, multi-faceted challenges for industry and the state. The book attempts to delve, assimilate, synthesize and disseminate such knowledge through its rich repository of resources.



### **Prof. (Dr.) Tushar Kanti**

A senior professional – Educationist and Navigator, Dr. Kanti, Group Director, Mangalmay Group of Institutions is a Ph.D in Management as well as Political Science. He has over 24 years of experience and over 24 published papers and 6 books to his credit. He has also been awarded the Life Time Achievement Award by Lions International and Certificate of Appreciation by Rotary Club.

### **Prof. (Dr.) J.N. Giri**

A seasoned administrator, Dr. Giri, Dean, School of Management Studies, Mangalmay Group of Institutions has over 18 years of experience. A graduate of BHU, he specializes in Marketing and Finance. He has a number of paper publications to his credit both in National and International Journals.

### **Prof. Harish Bhatia**

A tested academician, Prof. Harish Bhatia is Dean (Academics), Mangalmay Group of Institutions. His qualifications include B.Tech, MBA, PGDM & LLB. He has over three decades of experience in academics as well as the public and private sector in the field of Engineering & Technology.

[www.bloomsbury.com](http://www.bloomsbury.com) ₹ 999

ISBN 978-93-86432-66-7



9 789386 432667

BLOOMSBURY